



# NYC DOE DIIT School Standards

Technology & Innovation, Version 7.1

1/31/2023

## Table of Contents

<b>About This Document</b>	<b>5</b>
<b>About This Version</b>	<b>6</b>
<b>Section 1: Overview of Document</b>	<b>10</b>
Introduction .....	10
<b>Section 2: School Networking and Telecommunications</b>	<b>13</b>
Overview .....	13
General Installation Specifications .....	14
The House Book .....	15
Main Telecommunication Room Requirements .....	16
Intermediate Telecommunication Room Requirements .....	21
Equipment Placement Guidelines .....	22
Power Requirements .....	23
Riser Cabling and Terminations .....	25
Additions / Modifications .....	26
Horizontal Cabling and Terminations .....	27
Fiber Rising Cabling .....	30
Patch Panels .....	31
Circuit Installation and Demarcation Boundaries .....	31
Testing and Certification .....	31
Inter-building Pathway Design .....	32
Infrastructure for Voice and Data .....	33
Voice Cabling Infrastructure Specification .....	34
New Phone Lines .....	35
Voice Over IP (VOIP) .....	35
Security and Environmental Concerns .....	36
Clinics .....	37
Warranty and Maintenance .....	37
<b>Section 3: School Wireless</b>	<b>38</b>
Overview .....	38
Cisco Meraki MR56 Access Point .....	39
Features .....	40
Specifications .....	41
AP Guidelines .....	42
Guidelines for installation of APs in Auditoriums .....	45
Guidelines for installation of APs in Hallways/Corridors .....	47
Guidelines for installation of APs in Outdoor/Rooftop areas .....	49
AP Naming Convention .....	50
MR56 Signal Coverage Patterns .....	56
Wi-Fi 6 (802.11ax) FAQ .....	56

<b>Section 4: School IPDVS</b>	<b>58</b>
Overview .....	58
Core Network Infrastructure .....	63
Site Planning and Design.....	65
Electrical and General Contracting .....	75
Systems Integration .....	110
Confirming the Server Settings .....	166
Legacy Camera Systems .....	183
Commissioning and Transfer of Ownership.....	183
<b>Section 5: School Network Server</b>	<b>187</b>
Overview .....	187
Physical Hard Drive Setup .....	187
Integrated Management Module Setup .....	188
Network Connection for Host-01 .....	192
Verifications of Servers .....	200
<b>Section 6: School Networking</b>	<b>201</b>
Overview .....	201
Technology Descriptions.....	201
School Site and Room Classifications .....	204
Hardware Specifications .....	209
Network Component Details .....	212
Connectivity Infrastructure .....	216
Local Area Network Connectivity .....	221
Wide Area Network Connectivity .....	222
Network Addressing and VLAN Designation .....	223
Services .....	226
<b>Appendix A – School Cable Infrastructure</b>	<b>231</b>
Asbestos Testing and Protocol .....	231
Lockbox Specifications .....	231
Loud Bell .....	235
Cable Tags and Termination Labels .....	236
SCA Voice Rack.....	237
<b>Appendix B – School Wireless</b>	<b>240</b>
MR56 Installation Guide.....	240
Installation Instructions .....	242
Mount the AP .....	243
Physical Security .....	245
MR46E with E6 Narrow Patch Antenna Installation Guide .....	245
Installation .....	246
<b>Appendix C – School IPDVS</b>	<b>249</b>
Product Data Sheets .....	249

Comprehensive Technical Support.....	267
<b>Appendix D – School Networking</b>	<b>269</b>
Network Design Diagrams .....	269
IP Address Assignments.....	270
Network Component General Configurations .....	272
Network Component Summary.....	278
Component Naming Conventions .....	279
Equipment Heat Dissipation and Power Requirements.....	281
Integrating Legacy Devices.....	284
MDF Designs .....	286
IDF Designs .....	296
Unmanaged Switches .....	299
Software Versions.....	300
<b>Appendix E – School Network Component BOMs</b>	<b>302</b>
Components for Large School .....	302
Components for Medium School.....	305
Components for Wireless.....	308
Components for Small School .....	309
Miscellaneous Components (if needed) .....	311
IPDVS .....	311
Servers.....	318
Cabinets .....	318
Power .....	319
<b>Appendix F – Glossary of Terms</b>	<b>320</b>
Acronyms .....	320

## About This Document

---

The NYCDOE's Division of Instructional and Information Technology (DIIT) created this document to provide the information needed to assist the various divisions of the New York City Department of Education (NYCDOE) and the School Construction Authority (SCA) in creating and implementing a standards-based school network infrastructure.

The standards set forth in this document describe the components, features and functions required to support the current and anticipated future needs of school and/or administrative locations. This document also details the interaction between the Department of Education, the School Construction Authority and the various approved integration vendors involved in performing the technology implementation.

## About This Version

---

This section of the document is reserved for version control and tracking purposes. Due to the extensive information provided in this document, it has become increasingly difficult to determine the revisions and new additions to the Networking Standards. This section will serve as a repository for all significant changes to the overall document, and will be cataloged and documented in this section.

6/7/18 – V0.0	<ul style="list-style-type: none"> <li>• Creation of new consolidated document</li> <li>• Table of contents and outline submitted</li> <li>• Consolidation of all Standards Documents from groups including Cabling/Voice, Wireless, School IPDVS, School Server, School Network, and Administrative Offices</li> <li>• Reorganization of sections and removal of redundancy</li> </ul>
1/25/19 – V1.0	<ul style="list-style-type: none"> <li>• Publish the new Standards Document</li> <li>• New updated Wireless standard</li> <li>• New updated IPDVS standard</li> <li>• New updated school server</li> <li>• New firewall and router (terminal server)</li> <li>• New administrative offices standard</li> </ul>
2/14/19 – V1.1	<ul style="list-style-type: none"> <li>• Update the IPDVS section to include the UPS replacement process</li> </ul>
6/20/19 – V2.0	<ul style="list-style-type: none"> <li>• Updated wireless information to include Aruba and Cisco information</li> <li>• New port assignments for X66</li> <li>• Administrative Offices are removed (Section 7 and Appendix E)</li> <li>• New title for the Standards Document</li> <li>• Table of software versions for hardware added to Appendix D</li> </ul>
7/3/19 – V2.1	<ul style="list-style-type: none"> <li>• Async connections are explained when devices installed at the school do not match the configuration (Section 6)</li> </ul>
10/10/19 – V2.2	<ul style="list-style-type: none"> <li>• Update the wireless information in Section 3 and Appendix B</li> <li>• Update the software version for the 3845 router in Appendix D</li> </ul>
3/6/20 – V3.0	<ul style="list-style-type: none"> <li>• Update Appendix E to reflect new BOM</li> <li>• Update the Matrix on page 9</li> <li>• Make appropriate changes in Section 6 to reflect the new hardware in the BOM</li> <li>• Change Section 3 to reflect the new wireless standard</li> <li>• New software version for 2960X switch</li> </ul>
4/22/20 – V4.0	<ul style="list-style-type: none"> <li>• Update the product data sheet for IPDVS (see Appendix C)</li> <li>• Maximum number of APs per switch is now 18 <ul style="list-style-type: none"> <li>○ Found in Standard School Edge Switch Port Assignments (in Appendix D)</li> </ul> </li> <li>• Maximum number of devices per quad (see notes in table D14)</li> </ul>

	<ul style="list-style-type: none"> <li>○ 4 edge switches</li> <li>○ 40 access points</li> <li>• New school matrix (Small, Medium, and Large) <ul style="list-style-type: none"> <li>○ Mini schools are now Small schools</li> <li>○ Extra Large schools is now Large schools</li> <li>○ All other categories are consolidated</li> <li>○ Appendix E BOMs are updated</li> </ul> </li> <li>• New School Wireless section (section 3)</li> </ul>
4/23/20 – V4.1	<ul style="list-style-type: none"> <li>• Update School Wireless section (section 3)</li> <li>• New Wireless Appendix B</li> </ul>
2/5/21 – V5.0	<ul style="list-style-type: none"> <li>• Server pair goes into a closed cabinet (update figures D9 &amp; D10)</li> <li>• Update to power requirements <ul style="list-style-type: none"> <li>○ Table D23 changes the quantity of quad (5-20R) needed in MDF</li> <li>○ Table D23 replaces 220v/20 Amp with 220v/30 Amp power</li> </ul> </li> <li>• Update power requirements for MDF and IDF rooms <ul style="list-style-type: none"> <li>○ No longer using L6-20 receptacles for data cabinets (replaced with L6-30)</li> <li>○ Include L6-30 power receptacles in tables D20, D23, and D25</li> <li>○ Update Figures D12, D13, and D16 to include L6-30 outlets</li> </ul> </li> <li>• Update Figure 2-2 to show proper placement of wireless AP (center of the room)</li> <li>• New PDU model for core and classroom connectivity equipment (APC - AP9571A)</li> <li>• Update to power requirements in Table 1-1</li> <li>• New power cable included in BOM for any equipment installed in MDF/IDF plugging into new PDU (AP9571A)</li> <li>• Update Table D11 with correct port assignments for 9300-24 switch</li> <li>• Updated BOM for: <ul style="list-style-type: none"> <li>○ Large, Medium, and Small Schools</li> <li>○ IPDVS half height cabinet</li> <li>○ Data half height cabinet</li> <li>○ Data cabinet/rack PDU</li> </ul> </li> <li>• Small School IP address information (Table D7)</li> <li>• Update wireless information in Section 3 and Appendix B</li> <li>• Instructions to accessing the Cisco Smart Portal were added to the Technology Descriptions in Section 6</li> </ul>
10/4/21 – V6.0	<ul style="list-style-type: none"> <li>• Addition of Table D18 in Appendix D to show port assignments for core switch X66 connecting to legacy firewalls</li> <li>• New wireless standards <ul style="list-style-type: none"> <li>○ Access Point added to BOM</li> <li>○ New Section 3</li> </ul> </li> </ul>

	<ul style="list-style-type: none"> <li>○ New Appendix B</li> <li>• Access Points changes <ul style="list-style-type: none"> <li>○ No longer mounted on the ceiling located in the middle of the room (updated Figure 2-2)</li> <li>○ Maximum number of APs per switch is now 16 (Standard School Edge Switch Port Assignments in Appendix D)</li> </ul> </li> <li>• IPDVS power requirements for cabinets in Medium and Large schools are updated in tables 2-2, D21, D24, and D26, and figures D12 and D13 <ul style="list-style-type: none"> <li>○ MDF has 2 x 5-20R (quads) and 1 x L5-30R</li> <li>○ IDF has 2 x 5-20R (quads)</li> </ul> </li> <li>• Voice Over IP requirements added to section 2</li> <li>• New IPDVS standards</li> <li>• Updated BOMs in Appendix E</li> <li>• Updated Server standards <ul style="list-style-type: none"> <li>○ One server is used (not two)</li> </ul> </li> <li>• Core switch X66 is now called X0</li> <li>• Updates made to Table 1-1 <ul style="list-style-type: none"> <li>○ Power requirements for medium/large schools</li> <li>○ Wireless access points</li> <li>○ Voice over IP hardware</li> <li>○ Network hardware</li> </ul> </li> <li>• New IP address schema (Table D1)</li> </ul>
10/8/21 – V6.1	<ul style="list-style-type: none"> <li>• Table 6.13 was added to show new VLAN designation</li> <li>• Network Addressing and VLAN Designation (Section 6) was updated to show updated VLAN information</li> <li>• Minor corrections to IPDVS (section 4)</li> <li>• Update how to integrate legacy edge switches in Integrating Legacy Devices (Appendix D)</li> <li>• Power for small school should include a single quad (5-20R)</li> </ul>
11/12/21 – V6.2	<ul style="list-style-type: none"> <li>• Table E20 (power stacking cable) was deleted</li> <li>• Figure D9 (Medium School) is deleted and Figure D10 (Large School) is renamed and modified</li> <li>• Update port information in Tables D3 and D5</li> <li>• 12 strands of MM fiber are used for voice and all high density rooms</li> <li>• Instructions how to integrate legacy switches (less than 5 years old) in Appendix D</li> </ul>
1/19/22 – V6.3	<ul style="list-style-type: none"> <li>• Update minor corrections to Appendix D <ul style="list-style-type: none"> <li>○ Delete Figure D7 “mini school solution diagram”</li> <li>○ Update Figures D8, D9, D10, and D12</li> </ul> </li> <li>• Updated Wireless Section 3</li> </ul>

1/20/23 – V7.0	<ul style="list-style-type: none"> <li>• Detail added to the way legacy switches are handled when they have to stay on the network (Appendix D)</li> <li>• Updates to VLAN and SGT information in Table 6.13</li> <li>• Old VLAN mapping to new VLANs and SGTs in Table 6.14</li> <li>• Port assignment for Cisco router 8300 in new Table D3</li> <li>• IP address information for the TLS Gateway in new Table D4</li> <li>• Update port information of core switch X0 in table D7</li> <li>• Updated Wireless section (Section 3)</li> <li>• Update port assignments for core switch X0 (Table D7)</li> <li>• What to do when installing one or two switches in a computer lab is outlined in Section 2 (Power Requirements) and Appendix D (Equipment Heat Dissipation and Power Requirements)</li> <li>• IPDVS cameras will no longer have dedicated cabinets or switches and will connect to CCU switches</li> <li>• Section outlining how to handle non-standard devices are explained in the Unmanaged Switches part of Appendix D</li> <li>• New Meraki access points are now being used for classrooms (MR57)</li> </ul>
1/31/23 – V7.1	<ul style="list-style-type: none"> <li>• District Office is changed back to use VLAN 991</li> </ul>

## Section 1: Overview of Document

---

### *Introduction*

This document describes the DIIT standard network technologies deployed at NYCDOE schools. It reflects many criteria of the design and planning process for school technology at the NYCDOE. Perhaps the most important is the ability of the hardware to perform the tasks that are required for instructional and administrative tasks. However, other important considerations include: equipment management effectiveness, the flexibility of network solution services across a diverse set of school types and the expected resiliency of the overall school network environment.

This document organizes School Network Standards as follows:

**Section 2 – School Networking and Telecommunications:** specifies cabling infrastructure standards for various NYCDOE locations.

**Section 3 – School Wireless:** the hardware components required to support the new wireless solution.

**Section 4 – School IPDVS:** provide standards and guidelines for integrating IPDVS systems at NYCDOE school sites in compliance with the Citywide Policy for Implementing Video Management Systems.

**Section 5 – School Network Server:** explains how network equipment connects through DHCP.

**Section 6 – School Networking:** explains the technology currently being deployed by the DIIT in existing schools and the technology that should be deployed in new schools.

**Appendix A: School Cable Infrastructure**

**Appendix B: School Wireless**

**Appendix C: School IPDVS**

**Appendix D: School Networking**

**Appendix F: School Network Component BOMs**

**Appendix G: Glossary of Terms**

### **Distinction between the Site Classifications**

All classifications utilize standard hardware components and offer similar options for network connectivity. The primary distinctions between the site types, as summarized in Table1-1 below, are the types of hardware deployed at the different classified sites.

### **Technology Hardware Deployment Criteria for each Site Classification**

The definition of the site classification determines which core switch, Layer 2 switch, and firewall model to deploy at each school building. The classification also determines when the virtualized servers or the core switch will provide network services (DHCP).

**Table 1-1: Schools Networking Infrastructure Categories**

	Small <40 students	Medium 40-1000 Students <70 APs	Large >1000 Students >70 APs
<b>Infrastructure</b>	MDF Size	150 s.f.	300 s.f.
	MDF Cooling	24,000 BTU	34,000 BTU
	SCA PA System	room for cabinet	room for cabinet
	Clock System	Wall mount in MDF	Wall mount in MDF
	MDF - single 5-20R	0	0
	MDF - duplex 5-20R	1	0
	MDF - quad 5-20R	3	4
	MDF - single L5-30R	1	1
	MDF - single L6-30R	0	5
	IDF Size	1/4 height cabinet	100 s.f.
<b>IPDVS</b>	IDF Cooling	7000 BTU	7000 BTU
	IPDVS Server	Lenovo SR650	Lenovo SR650
	Genetec software	Security Center 5.9 K12 EDU	Security Center 5.9 K12 EDU
	Maximum Cameras	10	n/a
	IPDVS PTZ camera	AXIS Q6075-E, P3265-LVE (internal)	AXIS Q6075-E, P3265-LVE (internal)
	New Capacity PTZ Cameras *	Axis Q6075-E PTZ, Sony SNC-WR632RC, Samsung SNP-6321R (Indoor), Samsung SNP-6321H (Outdoor) or latest DIIT-approved replacement models	AXIS Q6075-E, P3265-LVE (internal)
	IPDVS Fixed Camera	AXIS P3375-LVE	AXIS P3375-LVE
	New Capacity Fixed Cameras *	Axis P3375-LVE, Sony SNC-EM602RC, Samsung SNP-6084R or latest DIIT-approved replacement models	AXIS P3375-LVE
	IPDVS Workstation	Lenovo P340	Lenovo P340
	Wireless Access Point (classroom)	Cisco Meraki MR57	Cisco Meraki MR57
<b>WiFi</b>	Wireless Access Point (hallways)	None	Cisco Meraki MR46E
	Wireless Access Point (outdoors)	None	Cisco Meraki MR86
	Phone System	None: POTS only	Cisco Unified Call Manager
	Voice mail	None: POTS only	Cisco Unity
	Phones	None: POTS only	8841 or 8851
	PRI	None: POTS only	1 fiber (preferred) or copper
	Conference	None: POTS only	8832 (if needed)
	Analog VG	None: POTS only	VG320
	PRI Gateway	none	ISR 4431 (if needed)
	Core Fiber Switch	None	Cisco C9500-48Y4C
<b>VOICE</b>	Core Copper Switch	n/a	Cisco Meraki MS390-48UX2
	Fire wall	None	None
	L2 Switch	Cisco C9300-24P	Cisco Meraki MS390-48UX2
	Web Cache	None	None
	Router	Cisco ISR 1111	Cisco C8300-2N2S
	Infrastructure Servers	None	ThinkSystem SR630
	Terminal Server	None	C1100TG-IN32A
	WAN Circuit	100 Mbps Crown Castle CAT 6	300 Mbps Crown Castle CAT 6
	New copper cable (Ethernet)	100 Meters	100 Meters
	Maximum length copper data	100 Meters	100 Meters
<b>Cable</b>	RJ45 insert colors	Voice=White, Data=Blue, IPDVS=Orange.	
	Fiber	50um OM4	50um OM4
	Maximum length Fiber	400 Meters	400 Meters
		N/A	

## Section 2: School Networking and Telecommunications

---

### Overview

The Department of Education is committed to providing a high bandwidth backbone in each building and school. All new cabling in buildings and schools must adhere to the latest specification of requirements for voice and data cabling published by the Division of Instructional and Information Technology (DIIT). This section specifies cabling infrastructure standards for various NYCDOE locations. Some are made in the context of new building construction, and some in the area of existing construction. Readers should discern the differences and use the sections that apply to their particular areas of discipline/concern. Although each site is different, and care must be taken to account for special needs if they exist, for the most part these standards conform to ANSI TIA/EIA-568-B documents. There are some additional requirements, and, in some cases, minor exceptions to the published TIA/EIA standards.

The Division of Instructional Information Technologies/Office of Telecommunications Services (DIIT/OTS), the School Construction Authority (SCA), and Contractor(s) will provide project management for all phases of installation activity. They are responsible for coordinating job actions, all communications pertaining to the job site and act as the principals through which deliverables and job progress are monitored.

In new construction, it is advisable that the OTS be included in the Design Development Review process from the 50% submission phase to the 100% review. This will help ensure that any scope of work includes the parameters defined in this voice standard.

In addition to core requirements, this document also contains guidelines for implementation practices. These guidelines were developed through the course of many school installations. Each site is different and care must be taken to account for special needs, on a site-by-site basis. The SCA, Contractor and OTS project management teams must work closely with the School's principal, the site administrators, and custodians to insure a successful installation of voice/data infrastructure.

Reference is also made to the **Main Telecommunications Closet** and **Intermediate Telecommunications Closet**. These rooms are also known as the equipment room, MDF and IDF. Typically, the main telecommunications closet houses centrally located voice and data (LAN) cabling and equipment as well as other electronic equipment including cabling for video surveillance system, and various building alarm systems. The Intermediate Telecommunications Closet houses voice and data station wiring plus some passive and active LAN equipment. Project managers/officers should be cognizant that future hardware may be located in these rooms, and should familiarize themselves with DIIT installations that have fully populated equipment rooms. The MDF should never be located in the basement, cellar, top floor or the roof of a building. This requirement is necessary to avoid water damage and other hazards to the equipment.

Please note that the DOE now has three different MDF designs to suit the five different network models:

**Table 2-1: School Size Categories**

Model	Criteria
Small-School Site	Less than 40 students – less than 5 classrooms, no phone system, 3 POTS lines maximum
Medium-School Site	Maximum of 1,000 students or 70 access points
Large-School Site	More than 1,000 students or 70 access points

The standard MDF design is used for Medium, and Large-School sites. The IDF designs for medium and large schools are the same. Small-Schools do not have an IDF.

This standards document is an evolving document. The references within this document are subject to revision and modification as necessary. Changes will be required over time to maintain support and compatibility with changing construction techniques and technological developments. You should always verify that you have the most recent revision of this document prior to development of construction requirements and/or installation or construction of voice- and data- related cabling in the Department of Education locations.

### ***General Installation Specifications***

Generally speaking, much of the following applies to Contractors working existing/retrofit jobs. The SCA and OTS project management teams will be familiar with these guidelines and monitor Contractors for compliance where applicable. Prior to the beginning of the work, a job meeting will take place. Typically, the meeting members will consist of representatives from the following offices: the OTS project manager, the Contractor and Subcontractor(s), the School Principal, the site Custodial Engineer, the telecommunications vendor, and where applicable, the data integration contractor. Key sheets, floor plans, Main and Intermediate Telecommunications Closets, cabling plans, and all schedules will be finalized at this meeting. Further meeting(s) may be necessary for finalizing all items.

The Contractor will minimize disruption to the School. Potential disruptions shall be discussed and reviewed with the OTS project manager, who will then communicate all pertinent information to School staff. There shall be no interruption of telephone service without written consent from DIIT.

The Contractor shall consult with the Custodial Engineer at the site regarding scheduling of deliveries and installation of equipment. The Contractor and OTS project manager shall be responsible for arranging the acceptance of all deliveries to the sites.

The Contractor is required to broom clean work areas at the end of each work shift so as to remove all dust and debris caused by drilling or nailing. The Contractor will not be required to mop. The Contractor will, however, make every effort to coordinate dust control with the OTS project manager and the School custodial staff. The Contractor will take necessary steps to protect furniture from dust and debris during installation activities. The Contractor shall take all necessary precautions so that occupants are not exposed to loose paint dust or materials that may contain lead as per the Division of School Facility guidelines.

For the most up-to-date guidelines, please access the DSF (Division of School Facilities) Dust Control Protocol, at:

<http://www.opt-osfns.org/nycdsf/>

The Contractor is required to utilize Contractor's tools, equipment, brooms, dustpans, and ladders. The School staff will not loan any tools or equipment. The Contractor must dispose of garbage, empty cartons and any other refuse in a manner acceptable to the custodian.

All Contractor personnel must wear company identification tags when working in DOE buildings.

Regarding installation activity that is potentially disruptive (i.e. drilling, running cables, mounting lock boxes and raceway, use of ladders, etc.): Contractor's installation price must reflect work scheduled between 3

PM to 11 PM, Monday to Friday. Contractor must include pricing that covers all custodial fees for work to be performed during non-school hours and days

Lockbox installation - Refer to APPENDIX A Lockbox Specifications for current lockbox installation requirements.

A lockbox must be implemented at each DOE site. It is used in a classroom for teachers to communicate with Administration, office staff, and/or security in the event of an emergency. The PBX can determine if the call will be an internal call or an external call. For any and all safety related considerations please contact the Office of Safety and Youth Development for proper guidance and recommendations.

### ***The House Book***

The Contractor shall supply two complete "House Books", one for the Main Telecommunications Closet and an additional copy for the OTS project manager. The House Book is to be provided in electronic media (disk or flash thumb drive) and shall minimally detail pair counts per IDF/MDF, copy of installation K-plans, floor plans showing jack locations and numbers, and printouts of all cable certifications tests.

All pre-approved, printed test results shall be incorporated into the House Book and left on site prior to soft cutover (or phased payment). An additional copy shall be given to the OTS project manager at the same time. System Acceptance and subsequent phased payment shall not be approved until the House Books are provided. The OTS project manager is responsible for instructing the Department Site Administrator both to the location and use of the site House Book. The OTS project manager shall locate the second House Book at the designated Office location.

Failure to amend fiber optic or copper cable(s) that have not passed testing, and/or failure to provide printed test results as described above, will be grounds for delaying System Acceptance pending completion of these items.

Tests of UTP cable shall be conducted with Level II-E Field Test Equipment (FTE). Test results shall be printed for every cable run and results reviewed for pass/fail by the SCA and/or the Contractor prior to formal submission to the DIIT for acceptance. Any voice-related cable runs that fail to meet minimal requirements must be repaired or replaced, and then re-tested for compliance. Final results will be incorporated into the "House Book". The House Book must document the FTE used for testing.

Fiber cable installation shall comply with the TIA/EIA component standards described in TIA/EIA-568-B.3. Fiber station cable shall be tested for end-to-end attenuation loss at 850nm and 1300nm. Procedures and documentation of fiber testing shall comply with the current TIA/EIA defined specifications at the time of job start-up. Test results shall be printed for each cable run and results reviewed for pass/fail by the SCA and/or Contractor prior to formal submission to DIIT for acceptance. Failed cable shall be corrected or replaced and re-tested. Final test results are to be compiled into the House Book. This section must indicate the FTE used for testing the fiber links and document proper test procedures.

At the closet end (MDF and/or IDF – depending upon cable design), the Contractor will terminate every pair of voice cable on a Category 6 compliant patch panel. All terminations in closets and station ends will be RJ-45 type, modular, eight-conductor, with outlets configured as per TIA/EIA jack designation T568B. All terminating backboards, patch panels, *connecting* cable, patch cords, wire management rings and trays, ladder racks for overhead wire management, labeling, 19 inch racks, and any and all other hardware necessary will be provided by the Contractor.

Cabled Administrative Stations, and pre-wires in Administrative Areas shall consist of two (2), four-pair cables; one Category 6 cable for voice, and one Category 6 cable for data. This administrative workstation

shall be terminated on a duplex combination faceplate consisting of two RJ-45 type, modular, eight-conductor outlets configured and terminated as per EIA/TIA jack designation T568B. The voice outlet will be located on top; the data on the bottom. The voice and data modular RJ-45 inserts will be color coded to differentiate between the two. Consistency will be maintained from site-to-site. The SCA contractor for consistency will run the following colored Cat6 cables; White cable for Voice, Blue cable for Data and Orange cable for Cameras. The only time this shall vary is when the existing site (if an addition or modification) follows a previous color standard. The Contractor shall document connecting hardware (Part number, Manufacturer, Category 6 Certification) in the House Book.

Wall phone station cable in the classrooms shall be Category 6 cable. All four pair cable will be terminated on a wall mount assembly (see APPENDIX A). Generally, this outlet will be placed in a lockbox, on the far, window-side of the classroom, near the classroom instructor's desk, so as to provide greatest accessibility. Exact location of outlets will be specified by the OTS project manager during K-plan preparation.

There may be exceptional, single Category 6 cable station runs. Some examples include: custodial work areas, elevator equipment rooms, boiler rooms, fan rooms and unique areas such as multipurpose or cafeteria. The OTS project manager will determine the location of these runs during K-plan preparation. These cables are for analogue devices, and shall be terminated in the closets on Category 6 patch panels, as described previously in this section.

All station outlets and MDF and IDF terminations must be labeled, and all circuits clearly identified, utilizing designation strips in compliance with TIA/EIA 606 standards. A permanent labeling machine, compliant with TIA/EIA 606 labeling standards must be used. Handwritten labels will not be accepted. APPENDIX A, Cable Tags and Termination Labels, includes additional details concerning labeling. At the closet end, all cable will be terminated at an IDF or MDF (if cable is 'homerun'). All Category 6 cable designated for voice cable in Administrative Areas will be cut down on patch panels located in a full 19" open rack. Voice cable shall be located at the top of the rack. The sizing for the administrative voice patch panels will be determined by working with the DOE Project Manager, and is determined by the number of stations wired back to that particular closet. The patch panel sizing will be determined as the base number of stations plus 25% growth.

Single patch panels will be limited to a maximum 48 ports (larger panels create congestion of patch cords). Each patch panel will have below it a '2U' wire management unit.

Example 1: an IDF supporting 65 administrative phones on that particular floor requires 120 patch panel ports. (65 ports + 25% growth is 97.5 ports. Two 48-port panels are just short of covering the growth factor. It is therefore necessary to add an additional 24-port patch panel for a total 120 ports). This configuration would have three (3) '2U' wire management units, one below each of the three patch panels.

Example 2: an IDF supporting 6 administrative phones on that particular floor requires one 24 patch panel. (6 ports + 25% growth is 7.5 ports. Rounding up there is a need for 14 ports. A single 24-port panel is sufficient to address the specification.) This configuration would have one (1) '2U' wire management unit located the single patch panel.

## ***Main Telecommunication Room Requirements***

The SCA cabling vendor shall submit a drawing of the telephone equipment room, showing layout of all components including necessary electrical outlets, conduits, and environmental requirements and wire termination fields prior to the start of the job. The Main Telecommunications Room or Main Distribution Facility should be centrally located, be dedicated as a single-purpose room, and be located at building ground level or above.

## Large School MDF

The Large School MDF will measure at least 300 sq. ft., and be dedicated as a single-purpose room. The MDF room may house any combination of a telephone, LAN/WAN, telco, video surveillance, and various building alarm systems. It should be dry, and at or above ground level. The room should also be accessible for wiring to and from the IDF. The MDF should not typically be located in the basement or cellar or on the top floor or roof of a building.

The Large School MDF requirements include the following:

1. Should be centrally located, and measure at least 300 sq. ft. of unobstructed usable space. If additional equipment is added to the room (outside of what was originally planned) then additional space should be added to accommodate for that equipment.
2. Wherever possible, it should house entrance facilities and demarcation points for the various telecommunications systems serving the building and the central grounding equipment for the telecommunications equipment.
3. Access to this room should be tightly controlled via a non-master key or access control card reader.
4. The data, voice, security and intercom/master clock systems should have their head-end equipment located within this facility.
5. Consideration should be given to the room's layout to allow for expansion of the data network, location of additional systems as they come online, and possible location of technician work space to repair equipment, troubleshoot network problems, or assemble new equipment.
6. Floor-mounted standard open data equipment racks may be used in spaces where student/staff access is limited; otherwise data equipment cabinets should be used.
7. The MDF should be interconnected with all other telecommunications rooms with a minimum of two (2) 4-inch conduit assemblies. Guidelines for these conduit systems can be referenced from TIA/EIA- 569-A.
8. The MDF should be located to minimize the number of IDFs, but not violate the "300-foot rule" (restriction of horizontal cable links to less than 100 meters or approximately 300 feet).
9. The MDF must contain three 42U open racks (model number SXAR3150) and one 42U equipment cabinet with appropriate vertical cable management between each rack. Space should be provisioned for a second cabinet and a cabinet installed if/when IP Digital Video Surveillance is implemented at the school. The set of racks and cabinets (including an IPDVS cabinet) should be aligned side- by-side and must have an open area measuring, at minimum, 3 feet around the perimeter of the equipment racks/cabinets. Refer to Figure D13 for the network equipment cabinet space and layout in the main telecommunications room.
10. The 42U cabinets must be 29" wide and 42" deep. Wider cabinets are not acceptable. Less-deep cabinets are not acceptable.
11. Terminate any associated voice cabling into voice rack. Specifications for the racks can be found in Appendix A. It's suggested the SCA purchase these racks to save time during installation and cable termination phases.
12. The Voice rack will not have power strips.
13. A ladder rack will run across the cabinets and rack. It will run to the wall near the Voice rack.
14. The ladder rack will be grounded to a common ground. The cabinets and rack will be grounded to the ladder rack.

15. A four foot by eight foot fire rated plywood will be installed on the wall parallel to and behind the cabinets and rack. The bottom will be three feet above the floor mounted horizontally on Kindoff standoffs which are to be mounted vertically.
16. A ladder rack will run from the wall above the plywood to the ladder rack above the cabinets and rack.
17. The data cabinet must have two PDUs plugged into the L6-30 outlets installed behind the cabinets.
18. The IPDVS cabinet has a UPS inside.
19. Electrical outlets for the Voice rack and Data racks will be mounted on the ladder rack above their respective cabinets.
20. Electrical outlets for the IPDVS cabinet will be terminated inside the IPDVS cabinet (model number SXAR3100) as shown in the following diagram.

The cabinets should be ordered with cable management. Each cabinet should receive:

- 1) Four horizontal cable management such as AR8426A or similar
- 2) Cable management rings in the front on the cabinet such as AR7540 or similar
- 3) Vertical cable management such as a pair of AR8442 or similar for the power cords in the back

### **Medium-School MDF**

The Medium-School MDF will measure at least 15ft. by 10ft. These 150 square feet must be usable & unobstructed. This room is dedicated as a single-purpose room. The MDF room may house telephone, LAN/WAN, telco, and video surveillance systems. It should be dry, and at or above ground level. The room should also be accessible for wiring to and from the IDFs. The MDF should not typically be located in the basement or cellar or on the top floor or roof of a building.

If another cabinet will be installed in the MDF, such as an Audio / Video system or PA system, the MDF room should be expanded to provide the same clearance as without it. If the additional cabinet is 2 ft. wide, the MDF should be 10 ft. by 17 ft. Sufficient space should be left in front of and behind the additional cabinet for maintenance. The additional cabinets cannot be placed in a way that it blocks front or back access to the other cabinets or rack. It also cannot be placed in a way that it prevents the other cabinets' doors from fully opening.

The Medium-School MDF requirements include the following:

- 1) Should be centrally located, and measure at least 150 sq. ft. of unobstructed usable space. If additional equipment is added to the room (outside of what was originally planned) then additional space should be added to accommodate for that equipment.
- 2) Wherever possible, it should house entrance facilities and demarcation points for the various telecommunications systems serving the building and the central grounding equipment for the telecommunications equipment.
- 3) Access to this room should be tightly controlled via a non-master key or access control card reader.
- 4) The data, voice, security and intercom/master clock systems should have their head-end equipment located within this facility.

- 5) The MDF should be interconnected with all other telecommunications rooms with minimum of two (2) 3-inch conduit assemblies. Guidelines for these conduit systems can be referenced from TIA/EIA- 569-A.
- 6) The MDF should be located to minimize the number of IDFs, but not violate the "300-foot rule" (restriction of horizontal cable links to less than 100 meters or approximately 300 feet).
- 7) The MDF must contain one 42U open rack (model number SVAR2400) and two 42U equipment cabinet with appropriate vertical cable management within each cabinet and around the rack. The set of racks and cabinets should be aligned side-by-side and must have an open area measuring, at minimum, 3 feet front and back as well as three feet to one side Refer to Figures D10 and D11 for the network equipment cabinet space and layout in the medium-school main telecommunications room.
- 8) The 42U cabinets must be 29" wide and 42" deep. Wider cabinets are not acceptable. Less-deep cabinets are not acceptable.
- 9) Terminate any associated voice cabling into voice rack. Specifications for the racks can be found in Appendix A. It's suggested the SCA purchase these racks to save time during installation and cable termination phases.
- 10) A ladder rack will run across the cabinets and rack. It will run to the wall near the Voice rack.
- 11) The ladder rack will be grounded to a common ground. The cabinets and rack will be grounded to the ladder rack.
- 12) The Voice rack will not have power strips.
- 13) A four foot by eight foot fire rated plywood will be installed on the wall parallel to and behind the cabinets and rack. The bottom will be three feet above the floor mounted horizontally on Kindoff standoffs which are to be mounted vertically.
- 14) A ladder rack will run from the wall above the plywood to the ladder rack above the cabinets and rack.
- 15) The data cabinet must have two PDUs in the cabinet and plugged into L6-30 outlets installed on the ladder rack above the cabinets.
- 16) The IPDVS cabinet has a UPS inside.
- 17) Electrical outlets for the Voice rack and Data racks will be mounted on the ladder rack above their respective cabinets.
- 18) Electrical outlets for the IPDVS cabinet will be terminated inside the IPDVS cabinet as shown in the following diagram (model number SXAR3100)

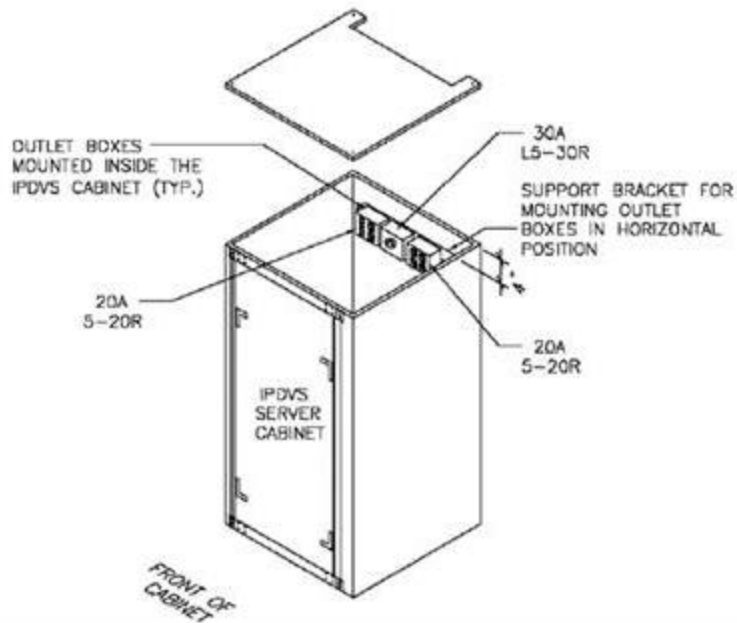

The cabinets should be ordered with cable management. Each cabinet should receive:

- 1) Four horizontal cable management such as AR8426A or similar
- 2) Cable management rings in the front on the cabinet such as AR7540 or similar
- 3) Vertical cable management such as a pair of AR8442 or similar for the power cords in the back

### Small-School MDF

The Small-School does not need a room dedicated for an MDF. The Small-School design requires a small cabinet located where it:

- 1) Must be protected from the outdoors
- 2) Must be near cable / EVPL outlet
- 3) Must have plywood to terminate WAN fiber
- 4) Must be protected from water
- 5) Must be away from students
- 6) Must have sufficient airflow
- 7) Must have sufficient power
  - a) Single quad (5-20R)
- 8) Must be secure

- 9) Must prevent Ethernet runs over 100 meters (if possible)

Here are some specifications for the Small-School MDF cabinet:

- 1) Inside height: 10 to 13 RU
- 2) Inside rack Width: Standard 19"
- 3) Inside depth: Allows at least 19" mounting depth

### ***Intermediate Telecommunication Room Requirements***

Small-Schools do not have IDFs. The specifications for Medium and Large-School IDFs are identical. This section covers Medium and Large-School sites.

The Intermediate Telecommunications Rooms (or Intermediate Distribution Facilities (IDF)) are single purpose rooms that are minimally 100-sq. ft. When choosing locations for new IDFs, they should be placed dedicated rooms without water/wash facilities. In addition to meeting foot print requirements, the location should have enough space, power capacity and HVAC to support infrastructure expansion. If wall mount cabinets are to be used, they are to be mounted, at most, 3 feet from the floor. If multiple Intermediate Telecommunication Rooms are utilized, stacked rooms or rooms located above each other are preferred. If wall mount cabinets are to be used, they are to be mounted, at most, 3 feet from the floor. If multiple Intermediate Telecommunication Rooms are utilized, stacked rooms or rooms located above each other are preferred. Ideally, horizontal Unshielded Twisted Pair (UTP) cables should be designed to run no more than 220 feet horizontally, measured from the IDF patch panel to the end-point/termination/jack. Consideration should be given for future expansion of telecommunication spaces and other systems without the need to assign new rooms for equipment. Adhering to industry standards for sizing IDFs based upon square footage of service area is recommended.

### **IDF Data and Voice Racks**

Currently, there is a data rack in each IDF Room in a school. Moving forward, we wish to provide the room with a second rack to support voice equipment, and to provide enough space to walk around these two racks. For this reason, we require a minimum area of approximately 100 square feet for each IDF. A sample of a typical IDF configuration is shown in Figure D-15, in Appendix D. Precise dimensions and interior placement will vary by school.

Figure D-16 indicates a possible configuration of equipment in both the IDF Data and Voice Racks. The actual configurations of both IDF racks vary from school to school, depending upon the needs of a particular building.

There is a 24-fiber interconnect panel terminating at the top of the data rack riser termination, as shown in Figure D-16. The IDF data rack contains 48-port patch panels and switches. These devices support both wired and wireless equipment (e.g., desktop computers, printers, wireless access points, etc.). Switches supporting wireless equipment must provide in-line power. The number of patch panels and switches will vary by school, and scale in direct proportion to the number of devices that must be supported. Fiber-optic cable connects the IDF data switches to the MDF.

There is a 24-fiber interconnect panel terminating at the top of the voice rack riser termination, as shown in Figure D-16 (specifications are in Appendix E). The IDF voice rack will contain 48 port patch panels and various configurations of voice switches. In the case of a large high school, the rack may also include voice server equipment. The number of patch panels and switches will vary by IDF, school, and scale in direct proportion to the number of devices that must be supported.

### ***Equipment Placement Guidelines***

- 1) Distribution racks and cabinets should be placed with proper consideration to clearances around the equipment, taking into account sources of EMI (electromagnetic interference), technician workspace, and sufficient walkways to avoid accidental disruption of service.
- 2) When IDFs cannot be dedicated to technology equipment, the data equipment should be partitioned away from other material or equipment by use of a lockable separation. If the space cannot be divided, then equipment cabinets for data equipment should be used instead of equipment racks.
- 3) Note that Figure D-15 is only illustrative; not every IDF will be precisely 10'x10'. As the dimensions of IDFs vary, so will rack placement within the IDF. Also, other equipment (e.g., cabinets for LONWORKS) may be required in some IDFs. However, some aspects of Figure D-15 apply to all IDFs:
  - a) There will be two, free-standing 7-foot data racks, one for voice, and one for data, in each IDF.
  - b) Space must be provided so that staff can get to all sides of the voice and data racks. The diagram shows spacing of 3 feet. Please note that these requirements apply only to the IDF. As indicated in section 9, voice and data racks in MDFs require 3 feet of clearance all the way around.
  - c) Overhead ladder racks will be used to run cables to all the racks. These ladder racks will also be used for running power lines for the equipment placed in the racks.
  - d) When IPDVS is deployed in a school, the IPDVS rack in the IDF is three feet high, and wall-mounted. It requires a minimum of 2 feet of clearance in front, allowing the front door to open, and a minimum of 6 inches of clearance on either side. These requirements apply only to the IDF. As indicated in section 9, MDFs require 3 feet of clearance all the way around
- 4) Equipment that should be located within each IDF/MDF should include:
  - a) Distribution racks or cabinets for mounting hardware.
  - b) Termination fields for fiber optic, UTP, and coaxial cables.
  - c) Core network equipment
  - d) Switches for the Local Area Network.
  - e) Amplifiers and other equipment for the CATV Distribution.
  - f) Rack-mounted Uninterruptible Power Sources (UPS).

**(For examples of MDF layout and Cabinet Elevations, refer to Appendix D)**

## Power Requirements

The appropriate power must be provided in the Main Telecommunication Room and Intermediate Telecommunication Room to accommodate the planned equipment to be installed.

### Large-School MDF

The telephone system must have a dedicated 24-hour circuit, which is separately fused. A school's duplex, 20amp dedicated AC outlet is required to power the peripheral equipment (i.e., call accounting PC, printers, MAT terminal, additional power supplies, etc.) and must be provided by the SCA cabling vendor in the Main Telecommunications Room. In addition, ten - (10) quad, dedicated, 110Volt 20 amp AC circuits with type 5-20R receptacles, 2 dedicated 220Volt 30 amp AC circuits with type L6-30R receptacles and two L5-30R receptacles will be installed in the MDF. These circuits will be located behind each of the three racks and two cabinet locations. The L6-30R receptacles shall be located behind the rack containing the Cisco 6880 chassis and the L5-30R receptacles shall be located behind the rack dedicated for IPDVS. Each rack and cabinet will also have two 5-20R quads, with dedicated 20 amp AC circuits. Each rack/cabinet will also be equipped with two 10-port horizontally mounted PDU. One (1) Quad Receptacle is attached to the telecom plywood backboard in the MDF.

### Medium-School MDF

The telephone system must have a dedicated 24-hour circuit, which is separately fused. A school's duplex, 20amp dedicated AC outlet is required to power the peripheral equipment (i.e., call accounting PC, printers, MAT terminal, additional power supplies, etc.) and must be provided by the SCA cabling vendor in the Main Telecommunications Room.

The IPDVS cabinet, Data cabinet, and voice rack will each have its own outlets mounted on the ladder rack above the cabinets and racks.

**Table 2-2: Power Requirements**

Volts / Amps	Outlets	IPDVS	Data	Voice	Plywood
110V / 20 Amp	single (5-20R)				
110V / 20 Amp	duplex (5-20R)			1	
110V / 20 Amp	quad (5-20R)	2			1
110V / 30 Amp	Single (L5-30R)	1			
220V / 30 Amp	Single (L6-30R)		2	1	

1. The outlets for IPDVS must be installed inside the IPDVS cabinet as shown below:

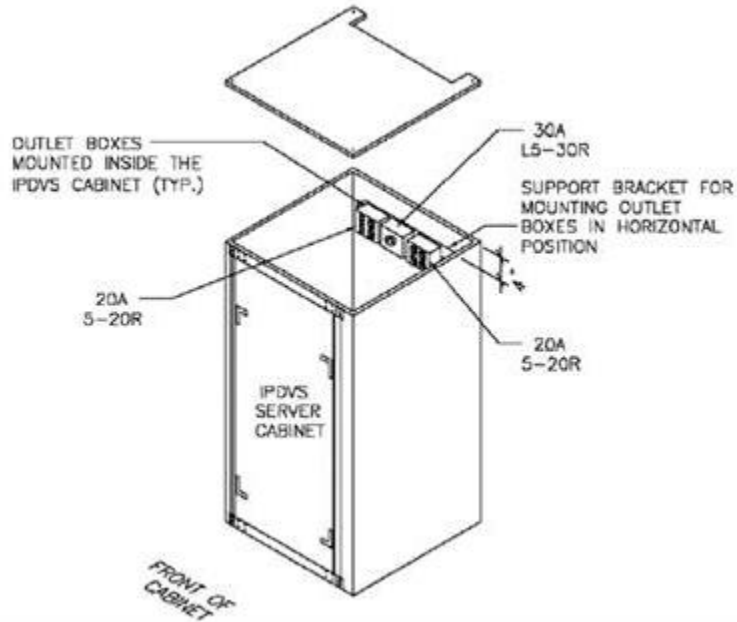

2. The outlets for Data must be installed on the side of the ladder rack above the Data cabinet
3. The outlets for Voice must be installed on the side of the ladder rack above the Voice rack
4. IPDVS will have one 110V / 30 Amp circuit with single L5-30R
5. IPDVS will have two 110V / 20 Amp circuit with quad L5-20R
6. Data will have two 110V / 30 Amp circuits with single L5-30R
7. Data will have two 220V / 30 Amp circuits with single L6-30R
8. Voice will have one 220V / 30 Amp circuit with quad L6-30R
9. Voice will have one 110V / 20 Amp circuit with duplex L5-20R
10. Voice will have an additional 110V / 20 Amp circuit with quad 5-20R outlets installed on the wall under the plywood, centered on the plywood and 18" above the floor.

### Concerning the IDF:

- 1) Two (2), 30-amp A/C receptacles (type L6-30R), located at least two feet apart must be provided within three (3) feet of the data cabinet in all Intermediate Telecommunications Room.
- 2) The PBX system shall be provided with a wall mounted surge protector that meets UL 1449 specifications. It shall protect (with automatic reset) connected equipment against transient surges and noise, delivering heavy-duty transient clamping within 5 nanoseconds with EMI/RFI filtering from 50dB attenuation at 340KHz. Peripheral equipment (e.g. call accounting systems and MAT terminals) should be similarly protected.

### Telecommunication Rack Grounding

The SCA cabling vendor will be responsible for properly grounding equipment in accordance with ANSI/TIA/EIA-607 and the NEC, including Article 800. All communications cabinets and racks at the Main Telecommunications Room and Intermediate Telecommunications Room must be grounded to a common earth ground with a minimum #6 AWG stranded copper line. Telecommunications Ground Bars must be installed in each rack/cabinet and on every IDF/MDF backboard.

### High Capacity Rooms

Rooms with a large number of wired connections that have a small cabinet, housing one (or two) switches, do not need an L6-30 outlet or PDU installed. Examples of this are computer labs. Below is a table to show what is needed.

Number of Switches	Outlet(s)
1 x Access Switch	1 x quad (5-20R)
2 x Access Switches	2 x quad (5-20R)
3 or more Access Switches	2 x Single (L6-30R)

### Riser Cabling and Terminations

Riser cabling for data consists of 24 strands of 50/125µm multi-mode fiber optic cable, running from the main telecommunications room or MDF to each intermediate telecommunications room or IDF. OM4 will be used for all fiber runs. Fiber Optic Cable (24-Strand) – shall be terminated at the MDF in rack mounted interconnect units with LC type connectors and shall be terminated at the IDF in rack mounted interconnect units with LC type connectors.

Additionally, 12 strands of multi-mode fiber should be used for voice connectivity. Termination at Intermediate Telecommunications Room and Main Telecommunications Room shall be at a rack-mounted interconnecting unit. Individual strands will be fanned out and terminated with LC connectors in an interconnect plate with twelve interconnect sleeves, following proper manufacturer's specifications for bend radius and strain relief.

In addition to the fiber backbone, six (6) Category-6 cables will be installed between the MDF and each IDF to provide a copper voice backbone for analog and/or other out-of-band network devices that require copper connectivity to the MDF room. The Category-6 cables will be terminated on a 24 port Category-6 patch panel in each IDF; at the MDF these cables will also be terminated on Category-6 patch panels, port count dependent upon the total number of copper riser cables installed. In all cases, the patch panel(s) will be mounted in the voice communication rack directly under the fiber optic interconnect enclosure. One (1) 1U horizontal wire manager will be installed immediately below the category 6 patch panel(s) in each room.

### ***Additions / Modifications***

When there is an addition and/or modification this is defined as structure(s) or component(s) added on or directly connected to an existing school. This can also be defined as a building placed in the school yard or playground of an existing site. In this case the new MDF/IDF created has to follow the normal standards for MDF to IDF. If a new MDF is to be designed it will be created as a large school MDF and the existing MDF will become an IDF. A new Verizon path can be created for use of alarm lines and other street services.

The riser cabling for voice consists of 12 strands of 50/125µm multi-mode fiber optic cable, running from the main telecommunications room or MDF to each intermediate telecommunications room or IDF. OM4 will be used for all fiber runs. Fiber Optic Cable (12-Strand) – shall be terminated at the MDF in rack mounted interconnect units with LC type connectors and shall be terminated at the IDF in rack mounted interconnect units with LC type connectors and will be fanned out and terminated with LC connectors in an interconnect plate with twelve interconnect sleeves, following proper manufacturer's specifications for bend radius and strain relief.

In addition to the fiber backbone, six (6) Category-6 cables will be installed between the MDF and each IDF to provide a copper voice backbone for digital devices. There is also a need to have Cat 3 copper installed between the existing MDF and new MDF and between every new IDF back to the new MDF. This cable would be installed on 110 blocks with C5 clips in both new MDF and old MDF. The purpose of this copper is to cover any existing station cables. The cable size should be calculated by the OTS PM or based on a current utilized pair count and increased by 30%.

Refer to Figure 2-1 for an illustration of voice and data horizontal/riser cabling.

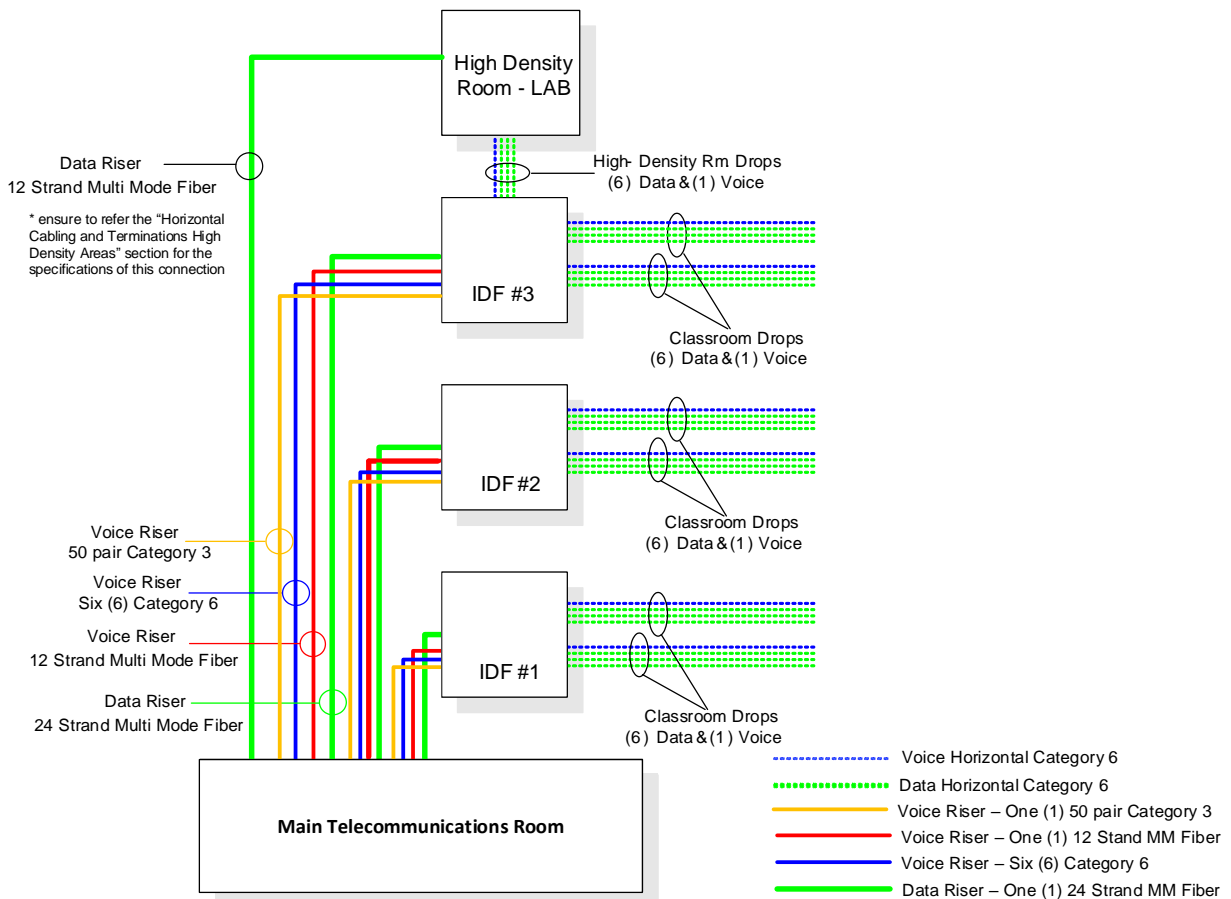

**Figure 2-1: Voice & Data Horizontal / Riser Cabling**

**Note:** if a school plans to use VoIP for all the phones in the building then there is no need to install CAT3 cables for voice.

### **Horizontal Cabling and Terminations**

When placement of the cabinet within the MDF, an IDF must be less than 90 meters (295 feet) panel to panel. Commercially manufactured patch cables will then be used for the remaining 10 meters to complete the channel link from the patch panel to the device.

### **Administrative Areas**

Voice and data drops in Administrative Areas shall consist of two (2) four-pair cables; one a Category-6 designated for voice, and the other a Category-6 cable designated for data for each user in the general office. Additional Category-6 cable station runs may be required for administrators located in offices throughout the building who need a fax or network printer and other school staff responsible for some aspect of school operations. Some examples include custodial work areas, nutritionist, school nurse, school safety, elevator equipment rooms, boiler rooms, fan rooms and building entrance and exit doors.

Specific locations will be determined during the building design phase by the school contact and the SCA Project Manager.

The station shall be terminated on a duplex combination faceplate consisting of two of the Cat-6 RJ-45 type, modular, and eight conductors, outlets configured and terminated as per EIA/TIA jack designation T568B.

The voice and data modular Cat-6 RJ-45 inserts shall be color coded to differentiate the two. Consistency must be maintained from site to site in a series of installations. A white insert for voice, a blue insert for data, and an orange insert for IPDVS are recommended.

### **Instructional Areas**

Wall phone station cable in the classrooms shall be Category-6 cable. All (4) pairs of the cable will be terminated on a wall mount. Generally, this outlet will be placed in a lock-box, on the far, window-side of the classroom, near the classroom instructor's desk, so as to provide greatest accessibility. The exact location of the outlet will be as specified by the DOE during K-plan preparation. The lock-box used must provide a means to connect a modular ITT 2554-type wall telephone with a message-waiting lamp. Data cable stations within classrooms and high-density areas shall be six Category-6 cables and in some isolated cases (defined later in this section) a six-strand, multi-mode 50/125 $\mu$ m (OM4 for all fiber runs) fiber optic cable. To the extent possible, the Category 6 cable runs should be run near allocated electrical outlets. Specifically, the cabling runs should be allocated as follows, illustrated in Figure 2-2:

- One run placed near an electrical outlet nearest to the classroom entrance
- Two runs placed near an electrical outlet nearest the corner of the room that has the teacher's desk
- Two runs located near the cluster of electrical outlets dedicated for classroom computers in the back of the room
- One run to be terminated directly in the Wireless AP. Occasionally, rooms larger than 1250 square feet will require a second wireless access point (WAP). This represents a change from current practice in which large rooms always required at least two WAPs. The change is a consequence of the new Next Generation Wireless architecture currently being deployed. With Next Generation Wireless, one WAP will often be adequate, even in large rooms. Rather than have integrators perform their own RF survey in large rooms to determine the best location for the second WAP as has been done in the past, SCA will work with DIIT engineering to determine the location of WAPs in large rooms in every school before any wiring is done.

At the telecommunication room end, all cable and pairs shall be terminated on Category-6 patch panels. All termination points shall be Cat-6 RJ-45 type, modular, eight conductors, with outlets configured as per TIA/EIA jack designation T568B.

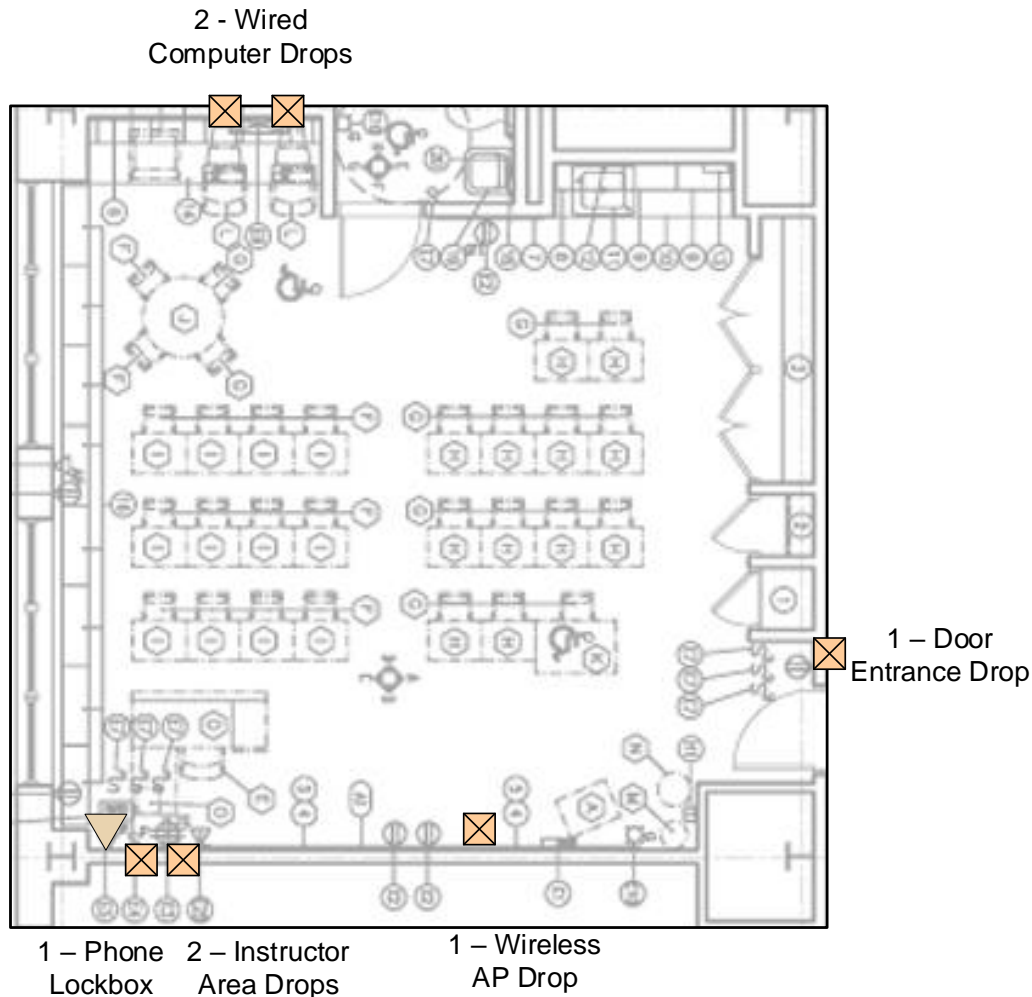

**Figure 2-2: Typical Classroom Wired Drop Layout**

### High Density Areas

Computer Labs and libraries/media centers are referred to as high density areas. These rooms often support multiple desk-top computers connected to a small switch. These rooms will receive a fiber run to guarantee a high speed connection from the switch in addition to the Category-6 data drops described above. The fiber run will consist of a twelve strand 50/125µm multi-mode fiber optic cable (OM4 for all fiber runs), run from the designated classroom/office directly to the MDF. Termination of fibers in high-density areas must be with LC connectors mounted within a duplex fiber communication outlet or a combination faceplate in conjunction with one or more of the Category-6 cable(s). The fiber optic cable shall be terminated within the Wall Cabinet. In general, this fiber run will include one termination in each high-density area. The DOE Project Manager will work with site administration to determine the appropriate numbers on a site-by-site basis.

## ***Fiber Rising Cabling***

When 6-strand 50/125 $\mu$ m multi-mode fiber optic cables are used, their installation shall adhere to the same guidelines applied when cable is installed in vertical shafts or risers. This is exclusive to voice cabling infrastructure only. The riser cabling for voice consists of 6-strand 50/125 $\mu$ m multi-mode fiber optic cable run from the main telecommunications room (MDF) to each intermediate room (IDF). Termination at IDF and MDF shall be at a rack-mounted interconnecting unit. Individual strands will be fanned out and terminated with LC connectors in an interconnect plate with six interconnect sleeves, following proper manufacturer's specifications for bend radius and strain relief.

Ladder racks will be required in both IDF and MDF equipment rooms for cable in cases where a bundled group of cables span a horizontal space of greater than 18 inches. The recommended part number is Chatsworth Black Universal Runway 10250-712 or its equivalent.

Where cable distances are exceeded, IDF closets will be created as needed to supplement the voice (and data) infrastructure. The ANSI TIA/EIA requires that total voice and data CAT6 cable length not exceed 100 meters from closet to end device.

All vertical (floor-to-floor) risers (or cable runs, in the case of all metal risers or cable runs) shall be run in appropriately sized conduit. Riser conduit, EMT, pull boxes and horizontal raceways (if used) must be installed with 30% free space for additional cable runs. Proper workmanship is essential to insure a durable cable plant. When running cable through dropped ceiling space, the Contractor shall use rings or black iron to suspend cable at minimum six-foot intervals, and assure proper strain relief. Fire-resistant tie wraps and loop fasteners shall be secured per ANSI TIA/EIA compliance, and not over-tightened. Care will be taken to preserve twists in UTP, minimize stretching, prevent abuse, and preserve integrity of cable and cable jacket. The minimum size of Wiremold (if utilized) approved for use is V-700. Bend radius requirements for Category 6 and fiber optic cable may dictate larger than 700-type molding, in which case larger molding shall be used.

The Contractor shall provide detailed design drawings of all cabling, telecommunication closets and riser paths prior to commencement of work. If, during the course of the installation it becomes necessary to modify plans, the SCA and/or the Contractor will work with the OTS project manager to identify alternative design(s), and document the changes. All cable must be concealed in ceilings or walls wherever possible. When such concealment is not possible, cable must be within metal raceway/molding. Cable must be properly supported and provided with strain relief in all cases. In cases where there are existing moldings on the walls at the 10 to 12 foot level, it may be acceptable to neatly and securely affix the cables on top of the molding, but only with authorization by the DIIT Project Manager, on a case-by-case basis. Other exceptions may be granted at DIIT Project Manager's discretion. Proper hardware must be used for installing and finishing raceways. Self-adhesive hardware, double-sided tape, duct tape, etc. are unacceptable. All floor and wall drilling necessary for running telephone cables must be performed by the SCA and/or Contractor. Cable runs through walls and floors must be in EMT or rigid conduit sleeves with 1/2" lips at each end. All plans affecting building construction must be submitted to DIIT prior to installation for advanced approval. In cases where ceiling crawl space will be used for running cables, every effort should be made to locate existing ceiling access doors or holes. If such access doors/holes don't already exist, the Contractor may create an opening no wider than 2' x 2'. Subsequently, the Contractor is then required to cover the opening with a metallic access panel. Telephone mounting cords shall not be draped across floors. Where floor-mounted jacks cannot be avoided, they are to be installed in recessed areas as close to the wall as possible or directly under desks or furniture away from the occupants' chairs and feet.

## ***Patch Panels***

The patch panels provide physical connectivity from the MDF/IDF to desktop locations. Each desktop location is equipped with a category six (Category-6) wiring receptacle. Workstations use a Category-6 patch-cable that extends from the LAN adapter to the local wiring receptacle. The patch panel also provides easy cross connections to the core network equipment that is housed in the MDF/IDF cabinets. The patch panels are housed in the Main Telecommunication Room patch panel rack with voice and data terminating to their respective racks.

All patch panels for data should be Category-6. Be sure to fully populate all jacks, even if all are not in initial use.

## ***Circuit Installation and Demarcation Boundaries***

To ensure the ability to add lines in the future, the SCA cabling vendor will require the data and/or voice service provider to place, at a minimum, a 100-pair cable from the outside plant to the building Point of Entrance. The local carrier must provide a 100 or 200-pair feeder cable from the telecommunications provider building Point of Entrance to the Main Telecommunications Room. Appropriate conduit must be provided by the SCA cabling vendor from the building point of entrance to the Main Telecommunication Room. From there the cabling in the MDF will terminate to the Network Interface Device (NID) provided by the data and/or voice service provider to add a single WAN connection.

## ***Testing and Certification***

Category-6 station cable will be tested end-to-end (from jack faceplate to associated IDF or MDF termination) according to the methods and criteria defined in TIA/EIA-568-B and any subsequent addenda. The vendor must use the latest Cat 6 default test provided with the test equipment. The SCA cabling vendor shall comply with TIA/EIA standards applicable at the time of job start-up, and price the installation accordingly.

Tests of UTP cable shall be conducted with Level II-E Field Test Equipment (FTE). Test results shall be printed for every cable run and results reviewed for pass/fail by the SCA cabling vendor prior to formal submission to the DOE for acceptance. Any cable run not meeting minimal requirements must be repaired or replaced, and then re-tested for compliance. In addition to the certification a voice and data run list is required for every site. The run list should be given to the DOE project manager and integrator at the time of installation / integration. A run list gives the following information:

1. Voice
  - a. Room number
  - b. Admin (18" AFF) / Classroom
  - c. Voice number
2. Data
  - a. Room number

- b. Admin (18" AFF) / Classroom / Wireless
- c. Data number

Fiber cable installation shall comply with the TIA/EIA component standards described in TIA/EIA-568-B.3. All strands shall be tested for end-to-end attenuation loss at 850nm and 1300nm. Procedure for the test shall use Optical Time Domain Reflectometers (OTDRs) and shall comply with EIA/TIA 526-14, Method B: Optical Power Loss Measurements of Installed Multi-mode Fiber Cable Plant. Failed strands shall be corrected or replaced and re-tested. Test results shall be printed for each cable run and results reviewed for pass/fail by the SCA cabling vendor prior to formal submission to the DOE for acceptance.

### ***Inter-building Pathway Design***

The Entrance Facility consists of the telephone service entrance to the building, including the entrance point and/or the point of entry through the building wall and continuing to the Main Distribution Frame Room (MDF). The entrance facility may contain the backbone pathways/infrastructure that links other buildings in a campus environment. The ANSI/TIA/EIA 569-A defines an entrance facility as any location when telecommunications service enters into a building and/or where backbone pathways link to other buildings in a campus community, i.e., a physical connection between buildings, linking MDF to MDF in each campus facility.

A service entrance pathway shall be provided. The basic methods for provisioning are underground, buried and aerial pathways. The OTS Project Manager will work with the SCA and/or Contractor to determine the pathways and all shall account for the following:

- Type and use of building
- Growth
- Difficulty of adding pathways in the future
- Alternate entrance
- Type and size of cables likely to be installed

The entrance room or space is the component of the entrance facility that provides space for the termination of the entrance backbone cable. In accordance with NEC Article 800 Section 800-50, exception No.3, the entrance or outside building cable shall be terminated and protected on a listed primary protector within 50 ft. of entering the building, where the PBX and other voice-related equipment is located in the MDF/IDF room.

The SCA, Contractor and OTS project management teams shall develop and find agreement on a drawing of the MDF/IDF room prior to active construction. The drawing will show layout of all components including necessary electrical outlets, conduits, and environmental requirements and wire termination fields prior to the start of the job. See Figures D11, D14, and D15 for sample drawings.

In the MDF and IDF, a separately fused, dedicated 24-hour circuit of the proper amperage is necessary to power the telephone system and a separate one (1) quad, 20amp double duplex, 20 amp dedicated A/C outlet to power the peripheral equipment (i.e., call accounting PC, printers, MAT terminal, additional power supplies, etc.) must be provided. In addition, two (2) quad, four (4) duplex dedicated, 20 amp A/C receptacles (type 5-20R) located at least two feet apart must be provided near the 19" rack in a Main Distribution Closet. One (1) quad, two (2) duplex dedicated, 20 amp A/C receptacles (type 5-20R) located

at least two feet apart must be provided in all Intermediate Telecommunications Closet(s). The telecommunications systems shall be provided with a wall-mounted surge protector that meets UL 1449 specifications. It shall protect (with automatic reset) connected equipment against transient surges and noise, delivering heavy-duty transient clamping within five nanoseconds with EMI/RFI filtering from 50dB attenuation at 340KHz. Peripheral equipment (e.g. call accounting systems and MAT terminals) shall be similarly protected. Recommended Brand: Best SP 6.

The MDF shall be air-conditioned 24 hours a day, 365 days a year. The manufacturers' suggested PBX environmental specification for maintaining air temperature, in combination with the requirements for all other devices in the room, shall be used to determine the appropriately sized air conditioner. Minimally, a 34,000 BTU system shall be installed for a standard school and 24,000 BTU for a small school. The vendor must be prepared to install doors, locks and/or cylinders for the security of the Main Telecommunications closet and Intermediate Telecommunications Closets. If an existing MDF/IDF door is adequate, but has no lock, a new lock or cylinder must be installed at the start of installation, and keys must be supplied to the site administrator, the custodian and the OTS project manager. Two complete sets of keys for each phone lockbox in the School will be formally given to the school Principals. One set will be given to the School custodian. The lockbox keys will always be universal.

### ***Infrastructure for Voice and Data***

These cabling specifications include horizontal and backbone wiring for both a telephone system and building-wide LAN infrastructure. All "horizontal" copper wiring from an MDF / IDF to a classroom, office or other will utilize Category 6 cabling for both voice and data drops. Riser cabling, for both voice and data, will utilize 50/125  $\mu$ m Multi-Mode (OM4 for all fiber runs) Fiber. In addition to this fiber backbone, six (6) Category-6 cables will be installed between the MDF and each IDF to provide a copper voice backbone for analog and/or other out-of-band network devices that require copper connectivity to the MDF room. Details will be provided later in the document.

The Department of Education expects the SCA cabling contractors to adhere to specifications found in the latest revision of the ANSI/TIA/EIA Standard entitled, "Commercial Building Telecommunications Cabling Standard", TIA/EIA-568-B and all relevant Addenda. The Department requires that all components including cable, connectors, outlets and patch cords meet or exceed applicable performance standards adopted by the TIA/EIA.

All station wiring shall be four 4-pair, Unshielded Twisted Pair (UTP), Category-6 cable with legible color coding of conductors, and in specific instances, 50/125 $\mu$ m (OM4 for all fiber runs), multi-mode, and multiple strand fiber optic cable. All UTP, fiber optic cable, patch panels and other components must adhere to performance levels specified in the TIA/EIA-568-B Standard. All cable must be approved by the Underwriters Laboratories, Inc. and must bear exterior jacket markings indicating type, category classification if applicable, fire rating of jacket material, number of conductors/strands, and gauge or thickness of copper or fiber pairs. In addition, patch panels and other components will be documented and labeled for compliance. All station outlets and MDF/IDF terminations must be labeled and all circuits clearly identified utilizing designation strips in compliance with the EIA/TIA 606 standards. A permanent-labeling machine, compliant with TIA/EIA 606 labeling standards must be used. Please refer to Cable Tags and Termination Labels detailed in Appendix A.

At the telecommunication room's MDF and/or IDF (depending upon cable design), the SCA cabling vendor will terminate every pair of every voice and data cable on Category-6 compliant patch panel(s). Voice and Data cables will be cut down on Category-6 compliant patch panels with Cat-6 RJ-45 type, eight conductor,

and modular receptacles. In addition to the fiber backbone, six (6) Category-6 cables will be installed between the MDF and each IDF to provide a copper voice backbone for digital devices. There is also a need to have Cat 3 copper installed between the existing MDF and new MDF and between every new IDF back to the new MDF. This cable would be installed on 110 blocks with C5 clips in both new MDF and old MDF. The purpose of this copper is to cover any existing station cables. The cable size should be calculated by the OTS PM or based on a current utilized pair count and increased by 30%.

### ***Voice Cabling Infrastructure Specification***

These specifications include horizontal and backbone cabling for a telephone system and its related infrastructure. DIIT requires that all components, including cable, connectors, outlets and patch cords, meet or exceed applicable performance standards adapted by the ANSI/TIA/EIA Standard entitled "Commercial Building Telecommunications Cabling Standard", TIA/EIA-568-B. The Contractor will provide all new voice-related cabling and terminal blocks.

In some cases, pre-existing TIA/EIA-568-B infrastructure has been installed at existing School structures. In these cases and prior to job start-up, the SCA, Contractor and OTS project management teams will meet on-site and identify best practices to integrate the pre-existing infrastructure to the new addition/design.

All station wiring shall be four (4) pair, Unshielded Twisted Pair (UTP), Category 6, 24-gauge cable with legible color coding of conductors, and in specific instances, 50/125µm multi-mode, multiple-strand fiber optic cable. All UTP, fiber optic cable, patch panels and other components must adhere to performance levels specified in the TIA/EIA-568-B Standard. All cable must be approved by the Underwriters Laboratories, Inc. and must bear exterior jacket markings indicating type, Category classification if applicable, fire rating of jacket material, number of conductors/strands, and gauge or thickness of copper or fiber pairs. In addition, patch panels and other components will be documented and labeled for compliance. The Contractor must supply the OTS with specification sheets for all low voltage cables to be installed prior to job start-up. If a change is to be made to either the lot or manufacture of the cable, DIIT shall be notified and supplied with specification sheets for the new cable.

It is not necessary to use plenum grade cable in non-plenum spaces. In plenum spaces and dust chutes, the cable must be of Type MPP/CMP (plenum rated), and have a jacket label indicating the same.

All Category 6 station cable (voice) will be tested end-to-end (from jack faceplate to associated MDF or IDF termination) according to the methods and criteria defined in TIA/EIA-568-B. The Contractor will test for Wire Map, Length, and Attenuation NEXT, return loss and ELFEXT, delay and delay skew. The Contractor shall comply with TIA/EIA standards applicable at the time of job start-up, and price the installation accordingly.

In addition to the fiber backbone, six (6) Category-6 cables will be installed between the MDF and each IDF to provide a copper voice backbone for digital devices. If there is also a need to have Cat 3 copper installed between the existing MDF and new MDF and between every new IDF back to the new MDF. This cable would be installed on 110 blocks with C5 clips in both new MDF and old MDF/ IDF. The purpose of this copper is to cover any existing station cables. The cable size should be calculated by the OTS PM or based on a current utilized pair count and increased by 30%.

## ***New Phone Lines***

For new building construction, the OTS project manager will meet with a Verizon Outside Plant Engineer to ascertain adequate cable and pairs feeds to satisfy all new service requirements. A contractor will be required to install appropriately sized EMT conduit from the MDF to the point of entrance in the new building construction. This will be a pathway for feeding Verizon cable to voice and data communications equipment in the MDF. The SCA and DIIT project managers will coordinate with the electrical or other SCA Contractors to insure the proper design and installation of this conduit. Working with the SCA project manager, the DIIT project manager will coordinate the installation of the Verizon cable from building entrance point to the MDF once the conduit is built and qualified as completed.

Once the above is accomplished, all requests for new School phone lines are submitted to the Office of Telecommunications by the OTS project manager via the following website:

<https://www.nycenet.edu/Administration/Offices/FinanceandAdministration/DIIT/Telecom/telecomorders/>

Alarm Line Requests are submitted by either DSF or SCA, via the same link.

Once submitted, installation is tracked to completion by the Office of Telecommunications Services.

## ***Voice Over IP (VOIP)***

Schools who have VoIP or plan to install it in their school will need to follow the guidelines below.

**Table 2-3: VoIP Hardware**

<b>VoIP Requirements</b>	<b>Hardware Needed</b>
SIP/PRI Gateway	Model: Cisco ISR 4461 (at DCs only)
SRST	Model Cisco ISR 4331 (not at schools)
Analog gateway (fax, analog phones)	Model: Cisco VG310 (24 ports) or 320 (48 ports)
Local Subscriber (Large sites only)	Not at schools
Wiring	CAT 6 (minimum of CAT 5E in existing schools)
Phone - conference rooms	Cisco 8832
Phone - admin	Cisco 8841
Phone - lobby	Cisco 3905
Classroom Lockbox - Existing	Analog Phone
Classroom Lockbox - New	Cisco 3905

**Table 2-4: VoIP Configurations**

Configuration	Requirements
QoS	Need for new Catalyst 8K and other school WAN routers. Then central aggregation.
PoE	Provided by standard switches
VLAN ID	501
Data vs. Voice	Data VLAN and Voice VLAN for each access port
Connectivity	Phone connects to switch. Other device connects to phone.
DHCP	Provided on core X1 switches

### ***Security and Environmental Concerns***

The Medium and Large-School Main Telecommunications Room must be air-conditioned 24 hours a day 365 days a year. At a minimum, a 34,000 BTU (approx. 3 ton) cooling system shall be installed for a large school and 24,000 BTU (approx. 2 ton) for a medium school. However, if other equipment specified by the school contact will be located in the Main Telecommunications Room, additional cooling must be provided. The SCA Engineer of Record will ensure that the HVAC system installed will meet the cooling requirements for the installed equipment and allow for a margin of growth. For efficiency, a “staged” system may be used to support future cooling capacity. This cooling request is driven by the heat dissipation requirements of the hardware to be placed in the MDF. When designing the air conditioning plant, SCA will take into account the location of the Classroom Connectivity (formerly Project Connect) equipment rack, which contains equipment likely to require significant cooling. The SCA Engineer of Record will also ensure that the cooling system provides proper air flow in the MDF so as to assure proper environmental conditions for equipment operation but cannot be within 2 feet of the cabinets. The drip pan for the cooling system cannot be located directly over any racks/cabinets and must be at least 7 feet off the ground.

Medium and large-school Intermediate Distribution Facilities must also be air-conditioned 24 hours a day, 365 days a year. At a minimum, a 7000 BTU cooling system shall be installed at least 2 feet away from the cabinets. The drip pan for the cooling system cannot be located directly over any racks/cabinets and must be at least 7 feet off the ground. As is the case with the MDF, if other equipment specified by the school contact will be located in the Intermediate Distribution Facility, sufficient cooling must be provided in addition to the stated DIIT’s minimum request.

Physical security for access to the Main Telecommunications Room and Intermediate Telecommunications Room must be provided. Both room types must be enclosed and locked at all times. Keys to these rooms should be held by the school principal or custodial staff and should be made readily available for service and maintenance staff. These are not shared rooms. They are dedicated for the building’s primary services.

## ***Clinics***

A Clinic is a medical space created within an existing structure. When a Clinic is created all new cabling Cat 6 should be run to a closet within the space also known as an IDF. All of the station cables will be terminated on patch panel which the cabling vendor will provide, (rack drawing Appendix 5). All cabling will be terminated/ labeled as per EIA/ TIA labeling standards and a run list will be provided to the DOE by cabling vendor. All of the cabling within this space must follow the standard IDF specifications which are detailed below.

The new MDF/IDF created has to follow the normal standards for MDF to IDF. The riser cabling for voice consists of six (6) strands of 50/125µm multi-mode fiber optic cable, running from the Main Telephone Closet (MDF) to each Intermediate Telephone Closet (IDF). The OM4 fiber will be used for all fiber runs. All Fiber Optic Cable (12-Strand) – shall be terminated at the MDF in rack mounted interconnect units with LC type connectors and shall be terminated at the IDF in rack mounted interconnect units with LC type connectors and will be fanned out and terminated with LC connectors in an interconnect plate with twelve interconnect sleeves, following proper manufacturer's specifications for bend radius and strain relief.

In addition to the fiber backbone, six (6) Category-6 cables will be installed between the MDF and each IDF to provide a copper voice backbone for digital devices. There is also a need to have Cat 3 or Cat 5 copper installed between the existing MDF and new IDF. This cable would be installed on 110 blocks with C5 clips in both new IDF and MDF only. The purpose of this copper is to cover any necessary analog instruments since all sites are not currently VoIP. The cable size should be determined by the OTS PM or based on a current utilized pair count and increased by 30%.

### **Clinic Phones:**

The DOE will provide intercom phones for every room within the space. The only dedicated out bound/ inbound lines will be 1 line for Reception desk, 1 fax line to reception area and 1 line to the Supervisor. These lines will be provided from the schools existing PRI.

## ***Warranty and Maintenance***

All telephone systems are maintained by vendors and administered by the DIIT, Office of Telecommunication Services. The maintenance agreements cover telephones and any components attached to the system such as voicemail. All equipment will be repaired or replaced provided it was not abused or vandalized.

Schools experiencing equipment or telephone problems should contact their respective vendor. Vendors will issue a service ticket and, when necessary, report affected phone lines directly to Verizon Repair. If the issues remain unresolved, or vendors are unresponsive, please email the Office of Telecommunication Services at [telecom@schools.nyc.gov](mailto:telecom@schools.nyc.gov) or call 718 935-2255.

## **Section 3: School Wireless**

---

### **Overview**

Wireless has become the new gateway to digital content, instructional planning and learning material. Wireless network connections make it easy to gain access to collaborative platforms and digital tools, social media, online learning resources, wiki-pages, and the broader Internet. With this increased use of wireless, DIIT keeps expanding to respond to the demand of the new wireless-focused learning environment. In this environment, every space within a school building is a potential learning environment and DIIT looks to provide reliability, flexibility, and mobility throughout these locations to enable students to take full advantage of wireless learning.

DIIT is providing enterprise-wide mobility and secure wireless access to NYCDOE stakeholder including students, teachers, administrators, partners and school's community. This new centralized cloud based wireless technology platform constitutes the foundation for NYCODE's Mobility and Wireless standard.

### **Consistent Wireless Infrastructure Deployment**

The coverage will increase the use and access to resources, increase students' engagement and allow students to bring their own devices for use in the school (BYOD). Allowing for BYOD will provide opportunities to students to continue to learn beyond the classroom walls. This initiative will support students' ability to interact and create endless opportunities for engaging their classmates and teachers. Many teachers currently conduct assignments through WhatsApp and other social media platforms and use wireless devices to assist students in creating work and study groups. Access to digital content is increasing, as is the demand for more bandwidth and the usage of wireless. In addition to this, many schools utilize wireless for non-instructional or utility devices. These devices make up the Internet of Things and can include a variety of equipment including refrigerators, air conditioners and other smart appliances used for transportation, food services and more.

In some situations, the wireless equipment specified by the standard document may not interoperate with the wireless equipment already in place at the school. In such situations, School Construction Authority planners, school building expansion business owners, school building additions project managers and school technology integrators should plan to retrofit the entire school wireless infrastructure when planning and budgeting school building expansions. The wireless Access Points, IDF inline power switches and cabling runs in the existing building should all be retrofitted per the latest up to date standard utilized to install the expansion or addition in scope.

In this current release of the standard, we focus on the hardware components required to support the new centralized cloud-based solution.

## Cisco Meraki MR56 Access Point



High Performance 802.11ax Wireless

The DOE wireless standard calls for deploying and implementing a **Centralized Cloud based Wireless Infrastructure** to manage wireless networks throughout all their schools and administrative locations.

The Cisco Meraki MR56 is the new standard 802.11ax Access Point selected for wireless infrastructure upgrades and new installations. It is a cloud-managed 8x8:8 802.11ax AP designed for next-generation deployments that offers high throughput, enterprise-grade security, resiliency, increased network intelligence and simple management.

### Cloud Management

Management of the MR56 is performed through the Meraki cloud, with an intuitive browser-based interface that enables rapid deployment without time-consuming training or costly certifications. Because the MR56 is self-configuring and managed over the web, it can be deployed at a remote location in a matter of minutes, even without on-site IT staff.

24x7 monitoring via the Meraki cloud delivers real-time alerts if a network encounters problem. Remote diagnostic tools enable immediate troubleshooting over the web so that distributed networks can be managed with a minimum of hassle.

The MR56's firmware is automatically kept up to date via the cloud. New features, bug fixes, and enhancements are delivered seamlessly over the web. This means no manual software updates to download or missing security patches to worry about.

### Cisco Meraki MR56 DOE Design

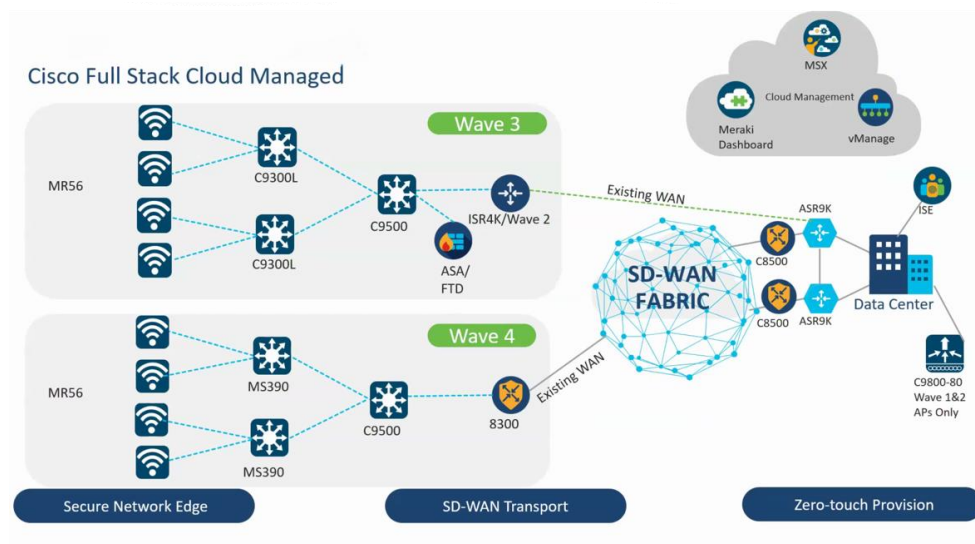

Cisco Meraki MR56 cloud Topology.

## **Features**

### **Dual–radio aggregate frame rate of up to 5.9 Gbps\***

2.4 GHz 4x4:4 radio and 5 GHz 8x8:8 radio offers a combined dual–radio aggregate frame rate of 5.9 Gbps\*, with up to 4,804 Mbps in the 5 GHz band and 1,147 Mbps in the 2.4 GHz band. Technologies like transmit beamforming and enhanced receive sensitivity allow the MR56 to support a higher client density than typical enterprise-class access points, resulting in better performance for more clients, from each AP.

### **Multi User Multiple Input Multiple Output (MU-MIMO)**

With support for features of 802.11ax, the MR56 offers MU-MIMO and OFDMA for more efficient transmission to multiple clients. Especially suited to environments with numerous mobile devices, MU-MIMO enables multiple clients to receive data simultaneously. This increases the total network performance and improves the end user experience.

### **Dedicated third radio delivers 24x7 wireless security and RF analytics**

The MR56's dedicated dual-band scanning and security radio continually assesses the environment, characterizing RF interference and containing wireless threats like rogue access points. There's no need to choose between wireless security, advanced RF analysis, and serving client data - a dedicated third radio means that all functions occur in real-time, without any impact to client traffic or AP throughput.

### **Bluetooth Low Energy Beacon and scanning radio**

An integrated fourth Bluetooth radio provides seamless deployment of BLE Beacon functionality and effortless visibility of Bluetooth devices. The MR56 enables the next generation of location-aware applications while future proofing deployments, ensuring it's ready for any new customer engagement strategies.

### **Automatic cloud-based RF optimization**

The MR56's sophisticated and automated RF optimization means that there is no need for the dedicated hardware and RF expertise typically required to tune a wireless network. The RF data collected by the dedicated third radio is continuously fed back to the Meraki cloud. This data is then used to automatically tune the channel selection, transmit power, and client connection settings for optimal performance under even the most challenging RF conditions.

### **Integrated enterprise security and guest access**

The MR56 features integrated, easy-to-use security technologies to provide secure connectivity for employees and guests alike. Advanced security features such as AES hardware-based encryption and Enterprise authentication with 802.1X and Active Directory integration provide wired-like security while still being easy to configure. One-click guest isolation provides secure, Internet-only access for visitors. PCI compliance reports check network settings against PCI requirements to simplify secure retail deployments.

### **Enterprise Mobility Management (EMM) & Mobile Device Management (MDM) integration**

Meraki Systems Manager natively integrates with the MR56 to offer automatic, context-aware security. Systems Manager's self-service enrollment helps to rapidly deploy MDM without installing additional equipment, and then dynamically tie firewall and traffic shaping policies to client posture.

### **Application-aware traffic shaping**

The MR56 includes an integrated layer 7 packet inspection, classification, and control engine, enabling the configuration of QoS policies based on traffic type, helping to prioritize mission-critical applications while setting limits on recreational traffic like peer-to-peer and video streaming. Policies can be implemented per network, per SSID, per user group, or per individual user for maximum flexibility and control.

## **Voice and video optimizations**

Industry standard QoS features are built-in and easy to configure. Wireless MultiMedia (WMM) access categories, 802.1p, and DSCP standards support all ensure important applications get prioritized correctly, not only on the MR56, but on other devices in the network. Unscheduled Automatic Power Save Delivery (U-APSD) and new Target Wait Time features in 802.11ax clients ensure minimal battery drain on wireless VoIP phones.

## **Self-configuring, self-maintaining, always up-to-date**

When plugged in, the MR56 automatically connects to the Meraki cloud, downloads its configuration, and joins the appropriate network. If new firmware is required, this is retrieved by the AP and updated automatically. This ensures the network is kept up-to-date with bug fixes, security updates, and new features.

## **Advanced analytics**

Drilling down into the details of network usage provides highly granular traffic analytics. Visibility into the physical world can be enhanced with journey tracking through location analytics. Visitor numbers, dwell time, repeat visit rates, and track trends can all be easily monitored in the dashboard and deeper analysis is enabled with raw data available via simple APIs.

## **Specifications**

### **Radios**

- 2.4 GHz 802.11b/g/n/ax client access radio
- 5 GHz 802.11a/n/ac/ax client access radio
- 2.4 GHz & 5 GHz dual-band WIDS/WIPS, spectrum analysis, & location analytics radio
- 2.4 GHz Bluetooth Low Energy (BLE) radio with Beacon and BLE scanning support
- Concurrent operation of all four radios

### **Speeds**

- Supports mGig and can connect at 1/2.5/5Gbps

### **Antenna**

- Internal Antenna (5.4 dBi gain at 2.4 GHz, 6 dBi gain at 5 GHz)

### **802.11ax, 802.11ac Wave 2 and 802.11n Capabilities**

- DL-OFDMA\*\*, UL-OFDMA\*\*, TWT support\*\*, BSS Coloring\*\*
- 8 x 8 multiple input, multiple output (MIMO) with eight spatial streams on 5GHz
- 4 x 4 multiple input, multiple output (MIMO) with four spatial streams on 2.4GHz
- SU-MIMO, UL MU-MIMO\*\* and DL MU-MIMO support
- Maximal ratio combining (MRC) & beamforming
- 20 and 40 MHz channels (802.11n); 20, 40, and 80 MHz channels (802.11ac Wave 2); 20, 40 and 80 MHz channels (802.11ax)
- Up to 1024-QAM on both 2.4 GHz & 5 GHz bands
- Packet aggregation

## Power

- Power over Ethernet: 42.5 - 57 V (802.3at compliant)
- Alternative: 12 V DC input
- Power consumption: 30W max (802.3at required)
- Power over Ethernet injector and DC adapter sold separately
- Note: Actual power consumption may vary depending on the AP usage.

## Interfaces

- 1x 100/1000/2.5G/5G BASE-T Ethernet (RJ45)
- 1x DC power connector (5.5 mm x 2.5 mm, center positive)

## Mounting

- All standard mounting hardware included
- Desktop, ceiling, and wall mount capable
- Ceiling tile rail (9/16, 15/16 or 1 1/2" flush or recessed rails), assorted cable junction boxes
- Bubble level on mounting cradle for accurate horizontal wall mounting

## Physical Security

- Two security screw options (included) (3.5 mm long and 2.5 mm diameter and 5 mm head)
- Kensington lock hard point

## Environment

- Operating temperature: 32 °F to 104 °F (0 °C to 40 °C)
- Humidity: 5 to 95% non-condensing

## Reliability

- Mean Time Between Failure (MTBF): 1,315,498hrs at +25°C operating temperature

## Physical Dimensions

- 12.83" x 5.54" x 1.76" (32.6 cm x 14.079 cm x 4.47 cm), not including desk mount feet or mount plate
- Weight: 35.27 oz (1 kg)

## ***AP Guidelines***

### **AP Replacement.**

Replace any existing access point following these guidelines:

- **Classrooms (MR56)**
  - 1:1 replacement with MR56
  - 2 APs in a classroom; replace with 1 AP-MR56 (unless it's a larger classroom that might have > 75 devices) Consider neighboring room and avoid back-to-back installs.

- 3 APs in a classroom; replace with 2 AP-MR56, (whichever two of the existing 3 are farthest apart)
- If a classroom can be divided into 2 separate classrooms using partition walls, install 2 MR56
  
- **Gyms (MR56 with AP Enclosure)**
  - 1:1 replacement with MR56
  - Leverage custom plastic enclosures (such as Acceltex) to protect equipment in gymnasiums from basketballs, etc.
  - For APs in enclosures, use enclosures with ventilation slots for proper heat dissipation
  - Additional APs can be added if size warrants
  - Surveyors needs to take dimensions
  
- **Cafeterias, Libraries, Computer Labs (MR56)**
  - 1:1 replacement with MR56
  - Additional APs can be added if size warrants
  - Surveyors needs to take dimensions
  
- **Office areas (MR56)**
  - 1:1 replacement or new with MR56
  
- **Auditoriums (MR46E with ANT-3-E6)**
  - Replace existing AP with MR46E + ANT-3-E6
  - AP placements to be strategized due to directional antennas.
  - Stagger APs accordingly left/right sides
  - Surveyor needs to make determination on actual antenna angle (ANT-3-E6)
  - Additional APs can be added if size warrants ( >75 clients)
  - Surveyors needs to take dimensions

#### **Category 2 (New Classroom/Instructional)**

Classroom, tutoring, college prep, nurse, guidance, areas used for student instructional purposes. (MR56)

#### **Category 3 (New Common Areas)**

Cafeteria, gym, library, Computer Labs (MR56)

#### **Category 4 (New 10+ Additional AP Admin)**

Admin office, principal's office, asst. principal's office, custodian, other. (AP-MR56) Limit 10 per bldg. code without additional approval.

#### **Category 5 Challenging RF environments (MR46E with ANT-3-E6)**

Wherever challenging RF environments necessitate directional coverage is required.

- **Hallways/Corridors.**
  - Please see "**Guidelines for installation of APs in Hallways/Corridors**
  - Use plexiglass to cover the wall after removal of existing hallway/corridor AP.
  - Cable vendor to examine and report the possibility of relocating of existing cable for corridors/hallways before proposing new runs.
  
- **Auditoriums.**
  - Please see "**Guidelines for Installation of APs in Auditoriums**"
  - AP placements to be strategized due to directional antennas.

- Stagger APs accordingly left/right sides
- Surveyor needs to make determination on actual antenna angle (**ANT-3-E6**)
- Additional APs can be added if size warrants ( >75 clients)
- Surveyors needs to take dimensions
- **In other large rooms or high ceilings (gym, cafeteria, etc.)**
  - Case-by-case basis, site survey recommended to determine hybrid of wall/ceiling mount placement in most cases
- **On a case-by-case basis for oddly shaped rooms, such as certain mechanical rooms**

### AP Placement.

The RF radiation patterns of the MR56 are designed to be spherical in nature and wall mounting with vertical orientation results in the same RF coverage throughout the classroom.

Avoid any corners or other physical obstructions. Make sure you do not install an AP near any electronic devices such as, microwave ovens, air conditioners, fans, or any other type of equipment that can cause signal interference.

The best method to determine wireless AP placement is to conduct an active wireless site survey. Another method is to simulate coverage using a predictive site survey. In the absence of these two methods, below are some high-level guidelines to assist with approximate placement.

**AP Placement (Classroom/Instructional) MR56** Classroom, tutoring, college prep, nurse, guidance, areas used for student instructional purposes.

APs should be mounted on the **Wall** not exceeding **15ft** in height, in a location that maximizes the coverage area such as the front-center of a classroom facing the students.

**AP Placement (Common Areas)** Cafeteria, gym, library, Computer Labs.

For these types of medium to high density areas, **Wall** mounted **MR56** APs not exceeding **15ft** in height will also suffice and allows DOE to remain consistent with all classroom APs. Of course, every deployment will vary, and a site survey is recommended.

**AP Placement (10+ Additional)** Admin office, principal's office, asst. principal's office, custodian, other.

Wall mounted **MR56** not exceeding **15ft** in height. Limit 10 per bldg. code without additional approval.

### AP Placement (“Common” Wall)

Make sure there is no AP mounted on the opposite side of the wall “common wall”. Having APs on common wall will result in significant overlap of RF lobes from APs in both rooms, resulting in signal loss and wireless clients flapping (wireless devices going from one AP to the other).

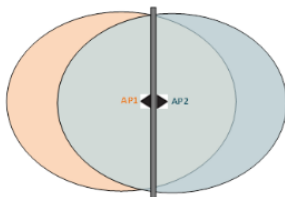

We need to avoid this by moving one of the APs away from the other. 6' or back of the classroom will do.

## Mechanical room

This would need to be examined on a case-by-case basis with a walkthrough, to make the best determination on how to effectively place the **AP** to cover this area.

**Do not paint MR46E- E6 antennas**, however they may be vinyl wrapped to blend in with surroundings



## AP Placement (“Auditoriums”)

See “*Guidelines for Installation of APs in Auditoriums*”

## AP Placement (“Hallways/Corridors”)

See “*Guidelines for Installation of APs in Hallways/Corridors*”

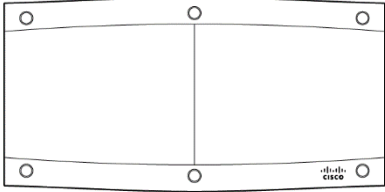
## Guidelines for installation of APs in Auditoriums

Meraki MR46E	ANT-3-E6 Narrow Patch Antenna
 A technical diagram of the Meraki MR46E antenna. It shows a rectangular device with a curved top and bottom edge. There are six circular mounting holes: two on the top edge and four on the bottom edge. A vertical line runs down the center of the device. The Cisco logo is visible in the bottom right corner.	 A photograph of the ANT-3-E6 Narrow Patch Antenna. It is a white, square-shaped device with a slightly raised center. Three cables are connected to the left side of the device.

For very high-density deployments such as a large auditorium with high ceilings 25 to 40 feet, deploying **MR46E** access points with external wide-patch antennas aimed down at the seating area is recommended.

One of the primary design priorities is spectrum re-use to have an efficient channel plan that avoids co-channel interference. We achieve that with directionality (patch antennas with narrow beamwidths) to intelligently re-use spectrum in the same large venue, essentially creating many somewhat overlapping "spotlights" of coverage, that is, more narrowly focusing the energy to minimize CCI and intentionally re-use spectrum.

### Placement.

The AP/antenna should be mounted on the **wall** between **10 to 15** feet above the floor level, with the antennas aimed directly at the center aisle/seats.

Placement is typically staggered between left & right walls such that no two antennas or coverage zones are directly in line - not directly pointing at one another.

A minimum distance of **30** feet is to be kept between Access Points to minimize interference.

**Example of wrong AP placement:**

- APs directly pointing at one-another

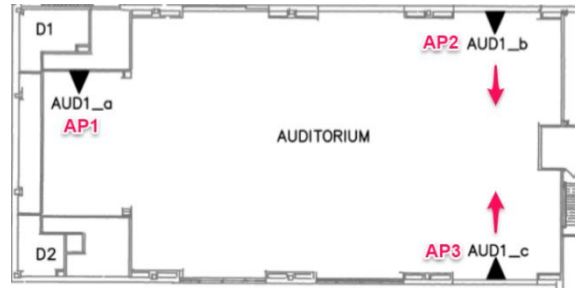

**Coverage.**

The wide patch antenna has a 60x60 degree coverage pattern, with a range of **250 to 300 feet** -67dBm. In open areas the signal can travel further but will decrease the signal strength. We need to maintain the levels between **-30** and **-67** dBm for good reliable Wi-F.

**Note:** Auditoriums are always a special case and should always have a walkthrough and predictive site survey since no two are ever alike.

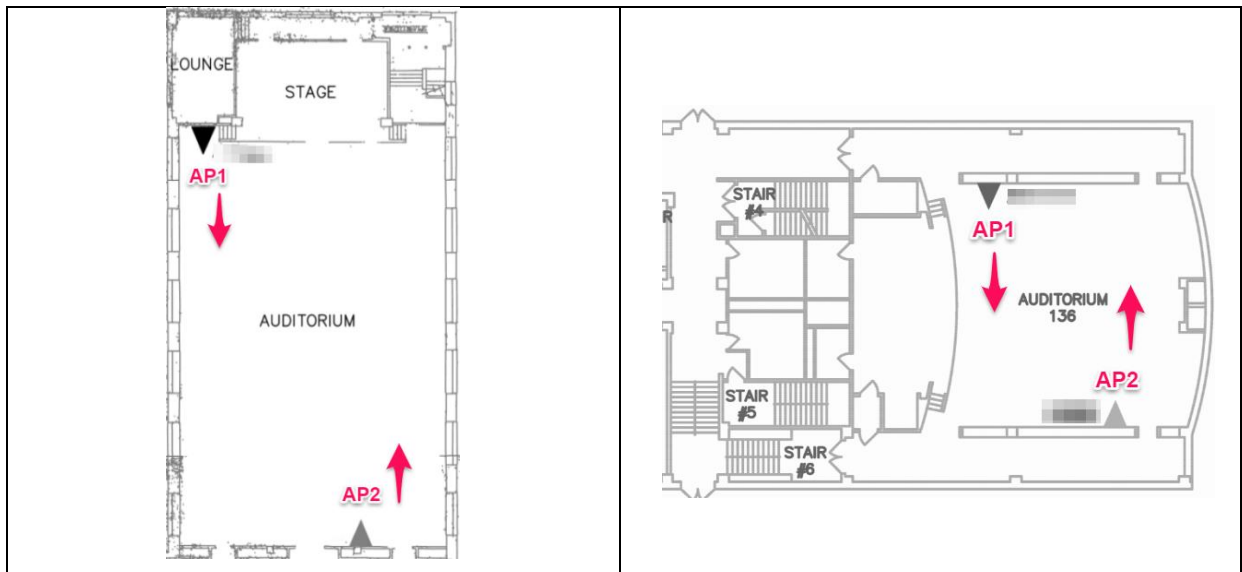

**Sample maps showing recommended AP placement**

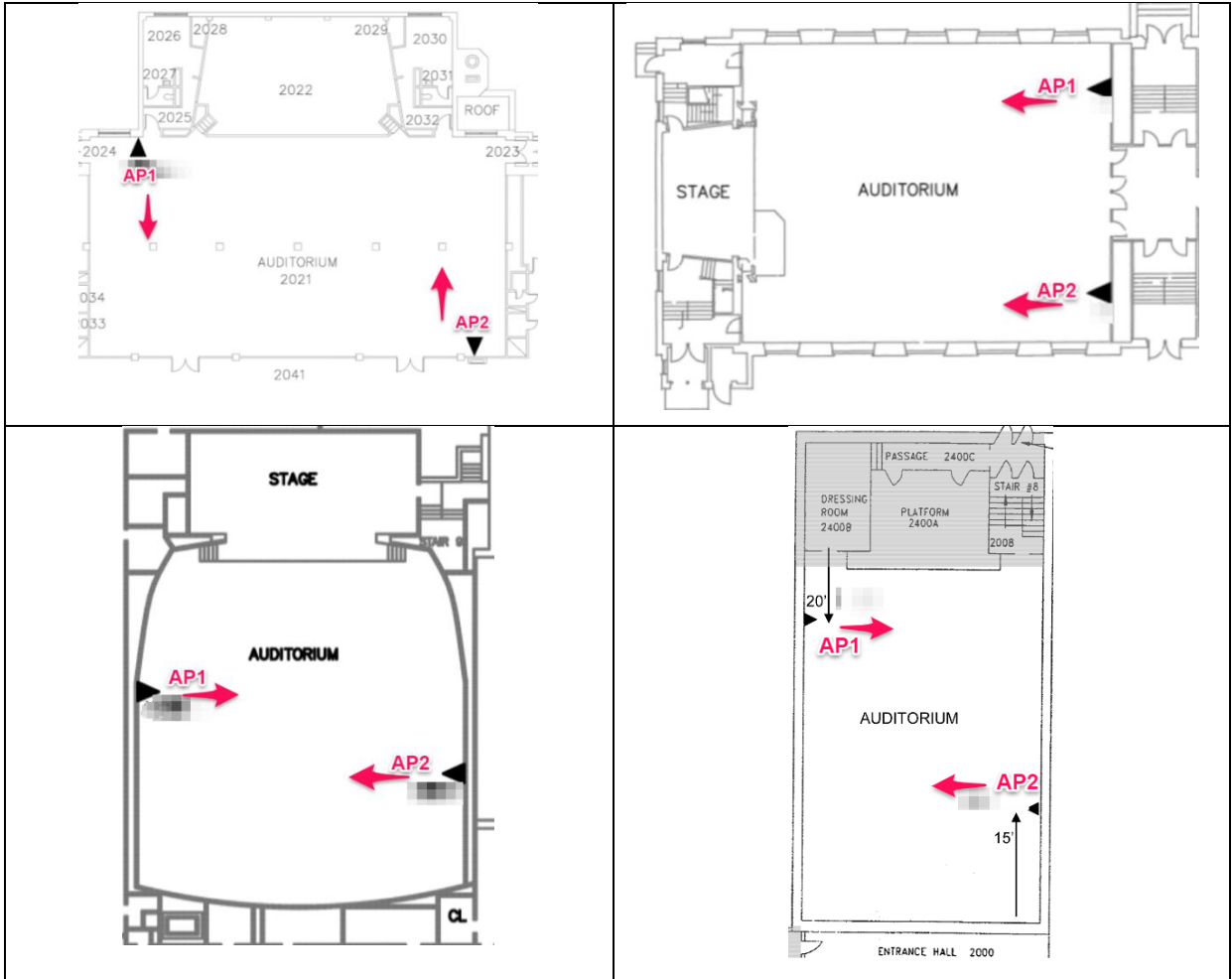

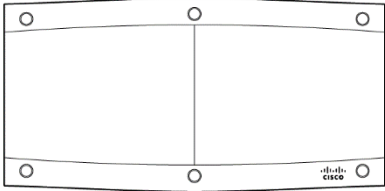

### ***Guidelines for installation of APs in Hallways/Corridors***

In most cases, it is expected that classroom AP's will provide coverage for hallways. However, both the TI team and the hardware manufacturer recommend that a **site survey** be conducted in hallways to validate coverage and to assess spillover from the classrooms due to building materials/construction. Where needed, the **MR46E** (and **E6 patch antenna**) would be installed at one end of a hallway and the E6 antenna aimed straight towards the opposite end. **Failure to follow this guidance may have negative impact on wireless connectivity in the classrooms.**

Meraki MR46E	ANT-3-E6 Wide Patch Antenna
	

MR46E with a wide patch aimed down a hallway is generally fine for up to **250-300** feet of linear corridor space, and could be handled with a single **MR46E and ANT3-E6** at one far end of such a hallway.

**For additional shapes and distances follow the recommendations bellow:**

**Short Hallway Coverage.**

- 300' or less
- E6 antenna aimed down the hallway.



**Long Hallway Coverage.**

- Up to 500' distance between 2 APs
- E6 antenna aimed straight towards the opposite E6 antenna



**L-Shape Hallway Coverage.**

- 300' or less
- E6 antenna aimed down the hallway.

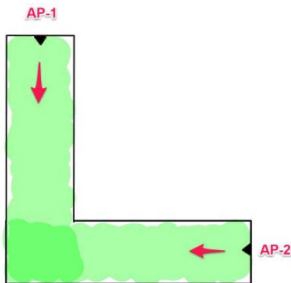

**T-Shape Corridor Coverage.**

- 300' or less.
- E6 antenna aimed down the hallway.

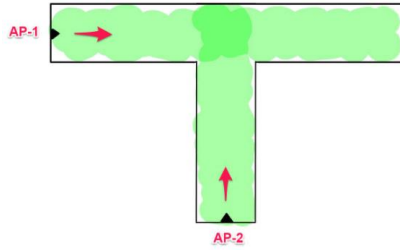

- Up to 500' distance between 2 APs.
- E6 antenna aimed straight towards the opposite E6 antenna.
- E6 antenna aimed down the hallway.

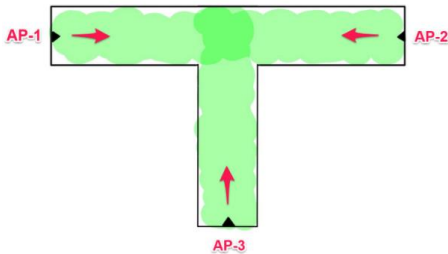

### ***Guidelines for installation of APs in Outdoor/Rooftop areas***



The Cisco Meraki MR86 AP is the new standard 802.11ax Access Point selected for **outdoor/rooftop** wireless deployments.

The **MR86** is a cloud-managed 4x4:4 802.11ax access point. It provides a maximum of 3.5 Gbps\* aggregate frame rate with concurrent 2.4 GHz and 5 GHz radios. A dedicated third radio provides real-time WIDS/WIPS with automated RF optimization, and a fourth integrated radio delivers Bluetooth scanning and beaconing.

Management of the MR86 is performed through the Meraki cloud, with an intuitive browser-based interface that enables rapid deployment without time-consuming training or costly certifications. Because the MR86 is self-configuring and managed over the web, it can be deployed at a remote location in a matter of minutes, even without on-site IT staff.

### **AP Placement Outdoor/Rooftop**

A proper site survey is recommended to determine the coverage area, AP placement and antenna type as well as what options exist for getting Cat6 wiring in place.

### **AP antenna ANT20.**

Standard ANT-20 omnidirectional antennas may be used for areas that will have outdoor coverage such as main entrance/exit areas, playgrounds or sports areas that are immediately adjacent to the building, perhaps within the first 100 to 200 feet. The ANT-20 comes in pairs, therefore order quantity 2 per AP. ANT-20 has N connectors and attaches directly to the four AP antenna ports.

### ***AP Naming Convention***

APs will be named using the following naming convention:

#### **RACKID\_Floor\_Room**

If you have more than 1 AP per room add: (**\_a, \_b, \_c**) at the end of the AP name:

**RACKID\_Floor\_Room\_a**

**RACKID\_Floor\_Room\_b**

#### **Floor Codes/Tags:**

<b>Floor</b>	<b>Code</b>	<b>Tag</b>
Ground	_G	groundFloor
Basement	_B	basement
Cellar	_C	cellar
Outdoor	_O	outdoor
Rooftop	_R	roofTop
Transportable Classroom Unit	_T	transportable
Mini Building	_M	miniBuilding
First floor	_1	1stFloor
Second floor	_2	2ndFloor
Third floor	_3	3rdFloor
Fourth floor.....	_4	4thFloor

**Room Codes/Tags:**

Room	Code	Tag
Gymnasium	GYM	gymnasium
Gym Office	GYO	gymOffice
Corridor	COR	corridor
Auditorium	AUD	auditorium
Cafeteria	CAF	cafeteria
Kitchen	KIT	kitchen
Library	LIB	library
Play Room	PLAY	playRoom
School Labs	LAB	lab
Admin Office	ADM	adminOffice
Nurse Office	NRS	nurseOffice
Guidance Office	GUI	guidanceOffice
Mechanical Room	MEC	mechanicalRoom
Music Room	MUS	musicRoom
Custodian	CUS	custodian
Art Room	ART	artRoom
Common Area	CMN	commonArea
Storage	STR	storage
Security	SEC	security
Swimming Pool	POOL	pool
Lobby area	LOB	lobby
Classroom	[0-9][A-Z]	classroom

**AP NAME examples:**

RACKID	Floor Tag	Room Location /	Number of APs	Final AP Name
24Q058	Basement	B34	1	24Q058_B_B34
24Q058	1stFloor	Gymnasium	2	24Q058_1_GYM_a 24Q058_1_GYM_b
24Q058	2ndFloor	Lab – room 212	2	24Q058_2_LAB_212_a 24Q058_2_LAB_212_b
24Q058	2ndFloor	lib – room 225	2	24Q058_2_LIB_225_a 24Q058_2_LIB_225_b
24Q058	3rdFloor	Corridor	2	24Q058_3_COR_a 24Q058_3_COR_b

24Q058	basement	Gymnasium	2	24Q058_B_GYM_a 24Q058_B_GYM_b
24Q058	transportable	T1 Unit #1	2	24Q058_T_T1_a 24Q058_T_T1_b
24Q058	transportable	T2 Unit #2	1	24Q058_T_T2
24Q058	rooftop	R1	2	24Q058_R_R1_a 24Q058_R_R1_b
24Q058	10 <sup>th</sup> Floor AUD 1	Auditorium	2	24Q058_10_AUD_A_a 24Q058_10_AUD_A_b
24Q058	10 <sup>th</sup> Floor AUD 2 (Room 1001)	Auditorium	2	24Q058_10_AUD_1001_a 24Q058_10_AUD_1001_b
24Q058	outdoor	N – North S – South E – East W - West	1 2 1 1	24Q058_O_N 24Q058_O_S_a 24Q058_O_S_b 24Q058_O_E 24Q058_O_W
24Q058	2ndFloor	Admin Office	1	24Q058_2_ADM_225
24Q058	3rdFloor	Admin Office A Admin Office B	1 1	24Q058_3_ADM_314A 24Q058_3_ADM_314B
24Q058	2ndFloor	Nurse Office	1	24Q058_2_NRS_225
24Q058	2ndFloor	Guidance Office	1	24Q058_2_GUI_225
24Q058	2ndFloor	Mechanical Room	1	24Q058_2_MEC_225
24Q058	3rdFloor	Classroom	1	24Q058_3_324
24Q058	1stFloor	Classroom	2	24Q058_1_115_a 24Q058_1_115_b
24Q058	1stFloor	Lobby	2	24Q058_1_LOB_1_a 24Q058_1_LOB_1_b
24Q058	4thFloor	Classroom	1 1	24Q058_4_415A 24Q058_4_415B
78X455	basement	Gym		78X455_B_GYM_1A_a 78X455_B_GYM_1A_b 78X455_B_GYM_1B_a 78X455_B_GYM_1B_b 78X455_B_GYM_2A_a 78X455_B_GYM_2A_b 78X455_B_GYM_3A_a 78X455_B_GYM_3A_b 78X455_B_GYM_3B_a

				78X455_B_GYM_3B_b 78X455_B_GYM_4A 78X455_B_GYM_4B 78X455_B_GYM_5A_a 78X455_B_GYM_5A_b
--	--	--	--	---------------------------------------------------------------------------------------------------

**AP Tags:**

<b>Tag Name</b>	<b>Description</b>
classroom	Regular school learning space
corridor	Corridors, Hallways, and open areas
cafeteria	Lunchroom, Food serving area
library	Library or media center
auditorium	A large room to accommodate an audience in the school
gymnasium	Indoor athletic area/physical education
adminOffice	Principal, assisting principal, main office
nurseOffice	A room that provides health education, health information as well as managing student health concerns.
guidanceOffice	Room used for student evaluation, counseling, placement, referral, remedial Services
mechanicalRoom	A room or space in the building dedicated to the mechanical equipment and its associated electrical equipment
musicRoom	Music and performing arts
lab	Any lab
storage	Storage area
transportable	Portable classrooms/trailers
miniBuilding	A building usually located behind the school to accommodate overcrowding school population.
pool	Swimming Pool area
lobby	Lobby area
security	Security desk or designated room for security personnel
1stFloor 2ndFloor 3rdFloor 4thFloor 5thFloor 6thFloor.... Basement	Building Floors:

Cellar groundFloor rooftop outdoor trailer minibuilding	
------------------------------------------------------------------------	--

**Network Tags:**

Tag Name	Description
queens-1 queens-2 Manhattan-1 Manhattan-2 brooklyn-1 brooklyn-2 bronx-1 bronx-2 statenIsland-1 statenIsland-2	Borough Tags:

**RF Profile**

Network RF Profile	Applied to tag
Classroom	classroom, artRoom, musicRoom
Admin Offices	nurseOffice, guidanceOffice, adminOffice, custodian, mechanicalRoom, security, gymOffice, kitchen.
High Density Area	library, cafeteria, gymnasium, lab, pool
Hallways	corridor, lobby,
Trailer	transportable
Auditorium	auditorium,
DOE Outdoor Profile	outdoor, rooftop,

## MR56 Signal Coverage Patterns

### 5Ghz Wireless

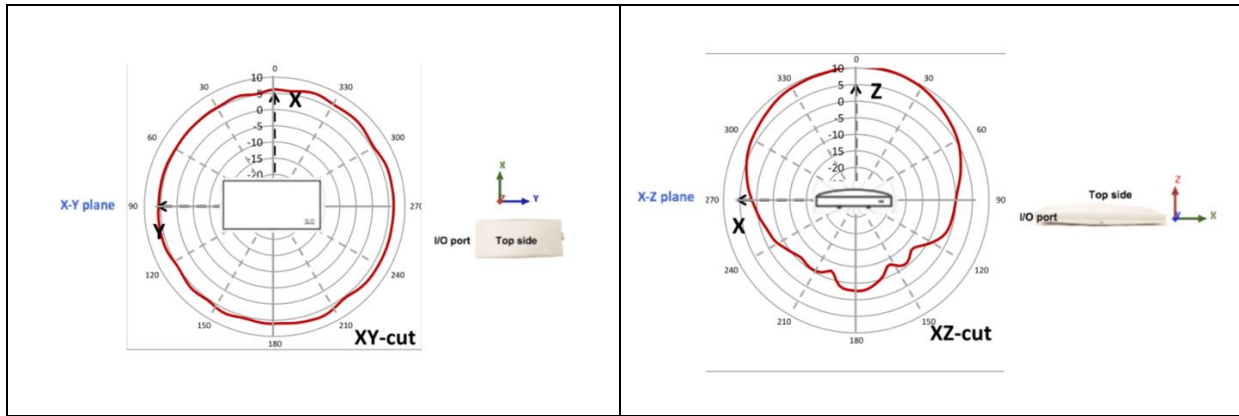

### 2.4 GHz - Wireless

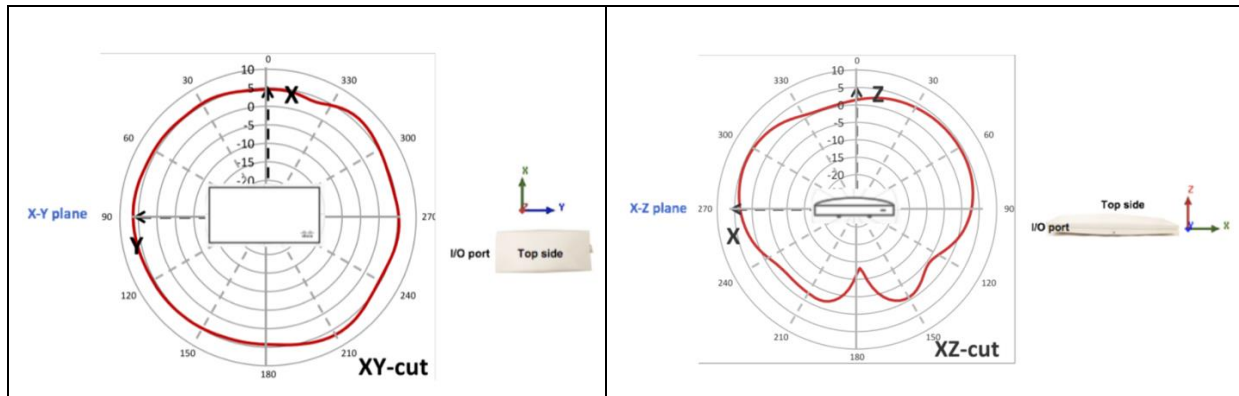

## Wi-Fi 6 (802.11ax) FAQ

### Q. What is Wi-Fi 6?

A. The emerging IEEE 802.11ax standard is the latest step in a journey of nonstop innovation. It builds on the strengths of 802.11ac while adding flexibility and scalability that lets new and existing networks power next-generation applications. IEEE 802.11ax couples the freedom and high speed of Gigabit Ethernet wireless with the reliability and predictability we find in licensed radio.

### Q. Is Wi-Fi 6 different from 802.11ax?

A. The Wi-Fi Alliance has started a campaign to use the term “Wi-Fi 6” when referring to the IEEE 802.11ax standard, indicating the sixth generation of Wi-Fi. The goal is to simplify the marketing message to better position Wi-Fi relative to the Third Generation Partnership Project (3GPP) standards used in cellular such as 5G which is the 5th Generation of 3GPP. The Wi-Fi 6 name is becoming very common now due to its simplicity. However, 802.11ax is interchangeable with Wi-Fi 6.

**Q. What additional features can I expect from Wi-Fi 6?**

A. Cisco, along with other vendors, has been working with the Institute of Electrical and Electronics Engineers (IEEE) on the Wi-Fi 6 standard. When ratified, Wi-Fi 6 will build on the success of 802.11ac, delivering a better experience in typical environments and more predictable performance for advanced applications such as 4K or 8K video; high-density, high-definition collaboration apps; all-wireless offices; and the Internet of Things (IoT). Wi-Fi 6 will drive Wi-Fi toward the future as the growth of wireless continues.

**Q. Will Wi-Fi 6 be backward compatible with previous generations of Wi-Fi?**

A. In Wi-Fi 6, all devices must also support all the mandatory 802.11a, b, g, n, and ac modes of operation. This ensures that Wi-Fi 6 Access Points (APs) and clients are backward compatible with legacy APs and clients.

**Q. Are my current mobile/client devices that use Wi-Fi 6 supported? When will mobile devices support Wi-Fi 6?**

A. Wi-Fi 6 devices have made it to the market during the last year. Leading mobile vendors and Cisco partners Apple, Intel, Microsoft and Samsung all have released Wi-Fi 6 products. Keep in mind that you need both an access point and clients that supports Wi-Fi 6 in order to realize the benefits of this new standard.

## Section 4: School IPDVS

---

### Overview

#### Introduction

The Division of Instructional and Information Technology (DIIT) has established revised standards to address the increasing need for improved video surveillance technology within the school network infrastructure. It is mandatory that DIIT, be consulted prior to any implementation of any video surveillance solution at school sites. The New York City Department of Education (NYCDOE) Standard Operating Procedures for OTPS (section 2.7.1.2) contain the following policies defining video surveillance under restricted purchases:

#### **2.7.1.2 Video Surveillance:**

- *All video surveillance installations are implemented through a centrally coordinated capital program at no charge to the participating schools. The Internet Protocol Digital Video Surveillance (IPDVS) systems are network-based with digital video archived to secure servers. The systems are maintained through the Division of Instructional and Information Technology DIIT's comprehensive technical support program.*
- *Schools are not permitted to purchase or install video surveillance cameras and/or surveillance equipment on their own. This is necessary to ensure that all systems adhere to DIIT standards and so that all systems can be properly maintained by DIIT. This is also necessary to ensure that NYCDOE has the ability to securely retrieve video evidence from the systems.*

The primary objectives and scope of this section are as follows:

1. Provide standards and guidelines for integrating IPDVS systems at NYCDOE school sites in compliance with the Citywide Policy for Implementing Video Management Systems. The citywide policy was last updated on February 27, 2015 and is available online at:  
[http://cityshare.nycnet/html/cityshare/downloads/policy/vms/video\\_management\\_system\\_policy.pdf](http://cityshare.nycnet/html/cityshare/downloads/policy/vms/video_management_system_policy.pdf)
2. Describe network infrastructure equipment, physical infrastructure enhancements and overall network reconfiguration to accommodate video system integration.
3. Current version IPDVS Standards applies to all projects to install digital cameras in a school building that presently lacks IPDVS as well as to all projects to replace existing analog IPDVS cameras with digital IP cameras (Complete Technical Refresh).

**The IPDVS standards are now part of the “NYC DOE DIIT School Standards”, and issued as one standard that will include IPDVS.**

This new version of the IPDVS standards will be in effect for all IPDVS sites with analog cameras and IP cameras. Any expansion of existing IPDVS sites that have analog cameras must conform to this current version.

The NYCDOE network infrastructure supports a mixed-camera environment, only in certain cases described below.

This mixed camera environment is now called the “Hybrid Solution”. See below description of the Advisory in effect as of 11/27/2018.

Description of Advisory Number FY2019-2 (Genetec Security Center 5.6 K12 Hybrid Solution)

The introduction to IPDVS Standards Version 7.0, published on 07/20/15, indicates “the NYC DOE network infrastructure will not support a mixed-camera environment, i.e. IPDVS installations shall not combine digital and analog cameras within a single building at a site, but can add IP cameras to an additional ANNEX or new IDFs.

While it is highly desirable to replace analog cameras in NYCDOE school buildings with digital IP cameras before increasing the number of cameras at a site, there may be some limited cases where the existing analog cameras have been installed too recently to be replaced using capital funding.

In these cases described below, IPDVS installations shall combine digital and analog cameras within a single site until analog cameras are phased out with digital IP cameras.

This IPDVS advisory addresses the need, in limited circumstances, to support mixed-camera environments, i.e. when digital IP cameras need to be added to sites that currently have analog cameras that are not capital eligible for replacement.

Mixed-camera or hybrid environments are only allowable under the latest software version, **Genetec Security Center 5.9.2.1 K12 package**. **NYCDOE no longer deploys any new analog camera systems with Genetec Omnicast versions 4.0, 4.7, 4.8 or Security Center 5.6**

Digital cameras may be added to sites with analog cameras to create a hybrid system under the following circumstances:

- a) Current IPDVS Analog sites with Omnicast version 4.8 or lower have been upgraded or scheduled to be upgraded to Genetec Security Center 5.9.2.1 K12 and a new IDF buildout is necessary to add cameras. The additional cameras will be digital IP cameras when a new IDF buildout is necessary.

OR

- b) An Annex is added to an existing site with Genetec Security Center 5.9.2.1 K12 and Analog cameras. The Annex will receive new IDFs with digital IP cameras.

Analog cameras may be added to existing site with analog cameras under the following circumstances:

- a) If a site remains with Omnicast version 4.8 or lower and there are sufficient ports in existing IDFs to support the addition;

OR

- b) If a site has Genetec SC 5.9.2.1 K12 and there are sufficient ports in existing IDFs to support the addition.

Guidance is available if needed by calling the IPDVS Deployment team at (718) 935-4800 or emailing [IPDVSDeployment@schools.nyc.gov](mailto:&IPDVSDeployment@schools.nyc.gov)

Specific Changes:

1. IP Scope to change to a class C /24 scope in a Hybrid Solution (QA & Engineering group will provide to Integrator).
2. All Verint Encoders will be re-assigned IPs starting with the 1st IP that would be assigned to an IP camera, followed by the rest of the IP cameras (QA & Engineering group will provide to Integrator).
3. Minimum Verint Encoder requirements when upgrading to Security Center 5.9.2.1 K12.
  - a. Verint Encoder 1712 series w/firmware version 5.00j Build 814 or higher. (firmware upgrade may be needed)
  - b. Verint encoder 1816 series w/firmware 2.4.11.68 or higher. (firmware upgrade may be needed)
  - c. All other model encoders should be noted during the initial site survey and scheduled for removal and swapped out with the two models specified above during Integration.
4. Snapshot pictures must be taken of existing Analog PTZ protocols and PTZ IDs in Omnicast versions 4.0, 4.7, or 4.8 before upgrading to Security Center 5.9.2.1 K12 Hybrid solution to ensure functionality. (Does not apply to PTZ capable IP cameras.)
5. Polarity for Analog PTZ functionality may need to be reversed when upgrading to Security Center 5.9.2.1 K12 Hybrid Solution.

**Current standard IP Cameras:**

Integrators should be using the AXIS Device Manager to look up and update the latest firmware for all AXIS IP Cameras. If Internet is not available, then a manual download is available through the AXIS website: <https://www.axis.com/support/firmware>

\*\* Note: Never downgrade firmware \*\*

<b>Current Standard IP Cameras</b>	<b>Minimum Firmware (at time of integration)</b>
<b>P3375-LVE – 2.1 MP – Fixed indoor/outdoor dome</b>	<b>9.80.3.1</b>
<b>M3057-PLVE MK II – 6 MP - 180°/360° Indoor/Outdoor</b>	<b>10.4.0</b>
<b>AXIS 3719-PLE – 4 Way 8MP – indoor/outdoor</b>	<b>10.4.0</b>
<b>AXIS P9106-V White – 3MP – corner camera</b>	<b>9.80.3.1</b>
<b>AXIS P5655-E – Indoor Small Form Factor PTZ</b>	<b>10.4.5</b>
<b>AXIS Q6075-E - Outdoor PTZ</b>	<b>10.4.5</b>

New Cameras introduced are as follows:

- Corner Camera
  - This camera can only be installed in a 90°-degree corner. (That is how the camera is designed).
  - When installed properly, this camera does not have a blind spot below the camera. The distance viewable down a hallway is fair, but not as perfect as the fixed camera.

- Short Throw
  - This is a single lens 360°/180° camera. It provides a fisheye/warp view. We primarily use this for the 180° view by wall mounting this camera.
  - The Genetec software can unwarped the image and provide 4 views based on the single lens.
  - The camera is ideal for tight places where the Corner Camera cannot be mounted.
  - This camera should be mounted at the center of the length of the wall rather - than near the corner.
  
- 4 Way
  - This camera contains 4 lenses in a circular housing. Each lens can be adjusted individually.
  - The goal of this camera is to look in 4 directions, or 3 directions + directly below the camera.
    - Each lens works like a typical fixed camera lens.
    - Each lens can be focused and zoomed in/out as needed.
  - Depending on the design, this camera will be installed exterior corner mounted to capture 270° FoV. It can be installed indoors via ceiling mount to capture multiple hallway/intersection.
    - This camera cannot be installed on an indoor wall – unless using an arm, which we do not intend to do.
  - Although this camera has 4 lenses, Genetec software only uses a single camera license. It does take up 4 camera recording views/retention space on the server.
  
- Indoor small form factor PTZ
  - In rare cases during design, there might be a request to use an indoor PTZ for large areas. A smaller form factor PTZ will be utilized for these cases.

The Fixed dome camera will continue to be the primary type of camera we use indoors and outdoors.

## Scope

Technological advances have made it cost-effective to install network-based surveillance systems that utilize the school system's existing information technology infrastructure. The use of IPDVS leverages the Department's previous and ongoing investments in local area networks through Classroom Connect and the wide area network through the Optical Ring for Instructional Support.

During fiscal year 2005, the Office of Safety and Youth Development (OSYD) commenced the IPDVS capital improvement project . In addition, the same network-based technology was subsequently incorporated into the New York City School Construction Authority (SCA) design requirements for capacity projects (new schools, large additions, and long-term leases). The DOE has not permitted any third-party video surveillance installations since 2004. Thus, for the past decade, all video surveillance installations in DOE school buildings have been network-based in accordance with DIIT's standards.

While the IPDVS program has been well received by schools, many administrators have communicated a desire for improved image quality on the archived video. During fiscal year 2015, DIIT successfully pilot tested an improved solution utilizing megapixel digital IP cameras that greatly enhance the quality of the video archives. That version of the standards (7.0) is based on the improved solution.

The intent of the IPDVS program is to create safer learning environments through the deployment of state-of-the-art video camera systems. Deployment of these systems allows authorized school officials to view

live and archived camera images directly on their computer stations and also provides remote viewing capability to authorized officials.

This project addresses the school system's critical need for a systemic approach to the planning, procurement, installation, and maintenance of video surveillance systems. The increased use of video surveillance is part of a comprehensive strategy to enhance school safety, particularly in schools with elevated incident rates. Historically, video surveillance in NYC schools was installed ad hoc and was not necessarily available in school buildings where it was most needed. Many of the Closed Circuit Television (CCTV) systems put in place prior to the launch of the IPDVS initiative were substandard, in a state of disrepair, underutilized, and/or lacked adequate recording capacity.

The IPDVS initiative provides network-based surveillance systems to schools that have had no operational surveillance system and when feasible, provides new systems for schools that have had antiquated surveillance equipment. All IPDVS systems are maintained through a comprehensive technical support program managed by DIIT. The goal of the support model is to ensure that problems are accurately logged, tracked, and directed to the appropriate resources for prompt resolution.

Video surveillance is a useful tool in improving the learning environment by reducing crime and disorder, particularly in buildings that have experienced elevated incident rates. First, the presence of video cameras deters misbehavior in and around school buildings. Second, the network-based solution provides schools with the flexibility to monitor the cameras from computer stations over their Administrative Network. This flexibility facilitates daily monitoring when school is in session so that school administrators and School Safety Agents (SSAs) can identify and take preemptive measures against potentially problematic situations, such as student loitering. Third, the IPDVS systems are sized to archive footage for every camera, enabling authorized personnel to access video feeds as necessary.

From the outset, the Capital Improvement Program (CIP) for IPDVS has concentrated on installing cameras at the sites assessed by both NYCDOE and NYPD as having the greatest need. The sites selected through the Capital Plan have been augmented by a diverse group of elementary and secondary school buildings whose inclusion in the IPDVS program was initiated by their receipt of Resolution-A allocations. As of April 1, 2021, IPDVS has been successfully implemented in 771 buildings serving 1013 schools with a total of 33,623 cameras online.

In addition, the same network-based technology has been incorporated into the New York City School Construction Authority (SCA) design requirements for capacity projects (new schools, large additions, and long-term leases).

Camera locations will generally include, but are not limited to, the following areas:

1. Exterior doors
2. Selected corridors
3. Selected stairwells
4. Student cafeterias
5. Auditoriums
6. Selected outdoor locations (e.g., playground, athletic field, approach to main entrance, loading dock, parking lot)
7. Areas outside all student locker rooms
8. Main telecommunications rooms

9. Additional cameras may be installed to monitor sensitive areas such as vestibules, storage areas, etc.

Cameras are not placed in areas where there is a reasonable expectation of privacy nor are they placed in instructional areas. Areas not under surveillance include:

1. Faculty or staff offices, including break areas and non-student cafeterias
2. Classrooms
3. Gymnasiums
4. Restrooms
5. Locker rooms

If there are any concerns that camera(s) may potentially be placed or have been placed in an area that does not agree with this policy, the matter should immediately be reported in writing to the DIIT Director for IPDVS Deployment.

Contact information for DIIT Manager of IPDVS Deployment:

Mr. Sedrick Assatir  
IPDVS Deployment  
2 MetroTech Center, Suite 3900  
Brooklyn, NY 11201  
718-935-5539  
[sassatir@schools.nyc.gov](mailto:sassatir@schools.nyc.gov)

For information regarding the IPDVS Capital Improvement Program, please contact:

Mr. Robert J. Weiner  
Chief Operating Officer  
Office of Safety & Youth Development  
52 Chambers St., Room 218  
New York, NY 10007  
212-374-4915  
[rweiner3@schools.nyc.gov](mailto:rweiner3@schools.nyc.gov)

## ***Core Network Infrastructure***

The school building site's core network equipment establishes the infrastructure for IPDVS. It provides both physical and logical connectivity for all attached devices at the site. This section reviews the standard network devices. This will be followed by a summary of network services provided by this hardware.

### **Infrastructure**

The IP digital video surveillance network is comprised of IP digital cameras, and an application server running proprietary software to process and manage the video feeds. Live video is streamed and captured

through IP digital cameras and uses structured cabling technology to provide power and signaling to the cameras. When the IP Digital Video Surveillance network system is deployed at NYCDOE school sites with existing network infrastructure components, deployment will attempt to minimize duplication of cable, wiring and communications infrastructure.

At the Intermediate Distribution Frame (IDF) closets, the IP digital cameras are networked and forward the digital video to the central video server in the school's Main Distribution Frame, using the existing network backbone of the school. This server provides authorized network users with access to live and archived video.

### **VLAN Segmentation**

The Service Network is a new school network that delivers a variety of services to the school. Each Service Network is isolated on its own virtual network segment. The Service Network is logically segregated from the school instructional network and the administrative network. The Service Network is segmented by application into isolated sub-networks. IPDVS has been assigned one of these sub-networks.

### Service Network Required Equipment

All Service Networks, including IPDVS, require Virtual Routing and Forwarding Routing enabled via X1. Please contact DIIT QA & Engineering Support group for assistance.

### IPDVS Network

1. IPDVS Servers
2. IPDVS Server Integrated Management Modules (IMM)
3. IPDVS IP Cameras
4. IPDVS Dedicated Viewing Consoles
5. Mid-Span PoE (Power over Ethernet)
6. APC UPS NMC (Network Management Card)
7. Cisco switches
8. Patch cables to all required network devices

### Administrative Network

Principals, Assistant Principals and Deans IPDVS Viewing Client PC(s)

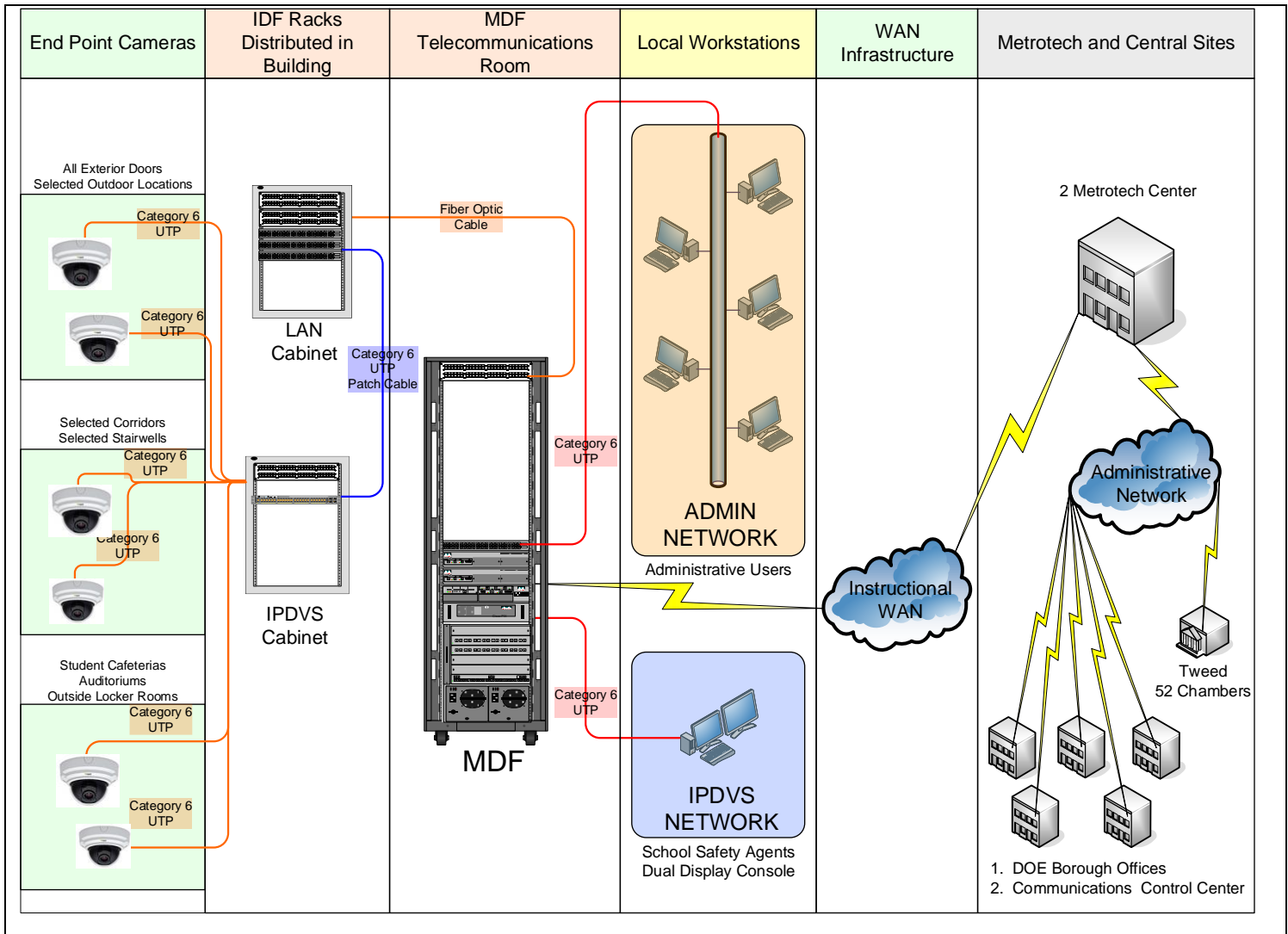

Figure 4-1 – LAN/WAN Conceptual Diagram

**\*\*\* Conceptual Diagram \*\*\***  
**Check with Appendix C for**  
**“Product Data Sheets” and**  
**Appendix D for “Network**  
**Component”**

### Site Planning and Design

This section provides design guidelines for planning an IPDVS installation. Please also refer to Design Requirement 7.3.11 published by the New York City School Construction Authority Architecture and Engineering Department.

#### General Guidelines

### Dedicated Technology Space

The location(s) where the IPDVS equipment will be installed must be planned carefully. The locations must be secure, maintainable by technicians without requiring ladders, accessible at any time during the school day, and ideally dedicated to telecommunications equipment. The Intermediate Telecommunications Rooms (IDFs) are to be single purpose rooms without water/wash facilities. If multiple Intermediate Telecommunication Rooms are utilized, stacked rooms or rooms located above each other are preferred.

1. Except rooms where telecommunications equipment already exists, IDF locations shall not be created in rooms with water/wash facilities or fixtures.
2. Wall mounted cabinets should not require a ladder to access the uppermost equipment space inside the cabinet.
3. The Division of School Facilities (DSF) Custodian Engineer (CE) must have keys to access the room.
4. Install IPDVS equipment in existing Classroom Connect, Telco or any other IDF cabinets or racks.
5. Cabinets are not to be placed in instructional spaces or administrative offices.
6. Wall mount cabinets are to be installed, at most, three (3) feet from the floor.

### Cooling Capacity

Equipment operating environments are a critical design element that must be considered when planning an IPDVS installation. The heat load of the IPDVS equipment must be taken into account along with the heat load of all other existing equipment in the room.

1. The HVAC system must cool the IPDVS server room space twenty-four (24) hours per day, three hundred sixty five (365) days per year.
2. Minimum Heating Ventilation Air Conditioning (HVAC) system capacity ratings:
  - a. Large School MDF 34,000 BTU/hr.
  - b. Medium School MDF 24,000 BTU/hr.
  - c. IDF 7,000 BTU/hr.
3. For SCA managed installations, including both CIP and capacity projects, it is the responsibility of the engineer of record to confirm the design provides adequate cooling capacity.
  - a. The responsibility of locating the condensate pump for split system units such that a malfunction cannot overflow onto any telecommunications equipment shall also be part of the responsibilities of the engineer of record.
4. For NYCDOE managed installations, it is the responsibility of the field project manager to ensure the location selected provides adequate cooling capacity.
5. The estimated heat load of average IPDVS cabinets is displayed below.

### Minimum Working Space – Server Cabinet

The IPDVS server cabinet should be aligned side by side with any existing cabinetry. Network equipment, including patch panels, must be mounted with all ports that can be cabled facing the front of the rack. Server equipment must be mounted with all cabling ports facing the back of the rack and all media (CD-ROM/USB/etc.) facing the front of the rack.

1. A minimum working space of three (3) feet from the front of the cabinet shall be available without having to move or rotate the cabinet from its normal operating position.

2. A minimum working space of three (3) feet from the rear and front of the cabinet shall be available by moving or rotating the cabinet within the limits of the service loop cabling.
3. The data and electrical cabling entering the cabinet shall provide for a properly strain relieved service loop that will allow the cabinet to move three (3) feet in any direction from its normal operating position and orientation.

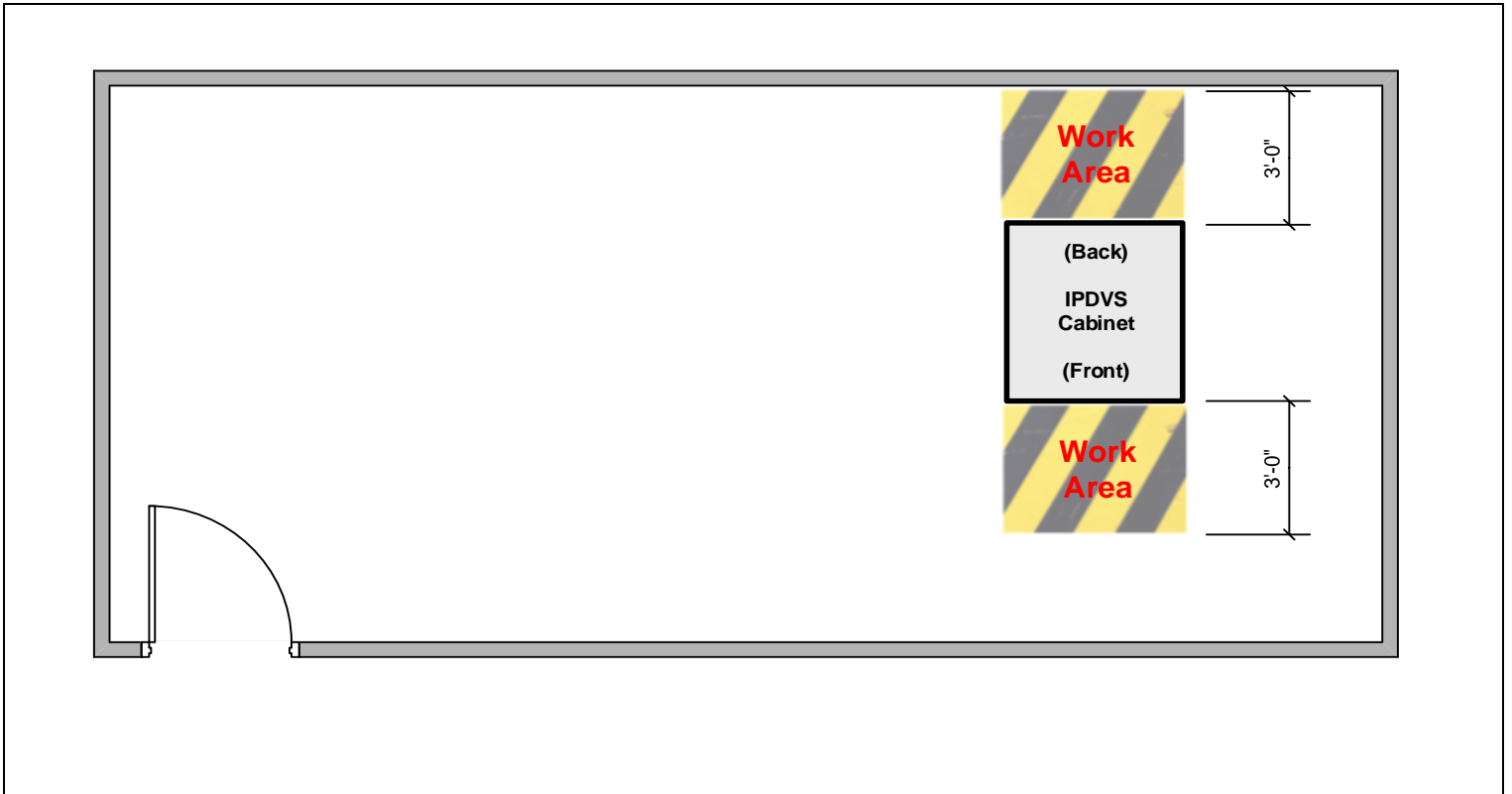
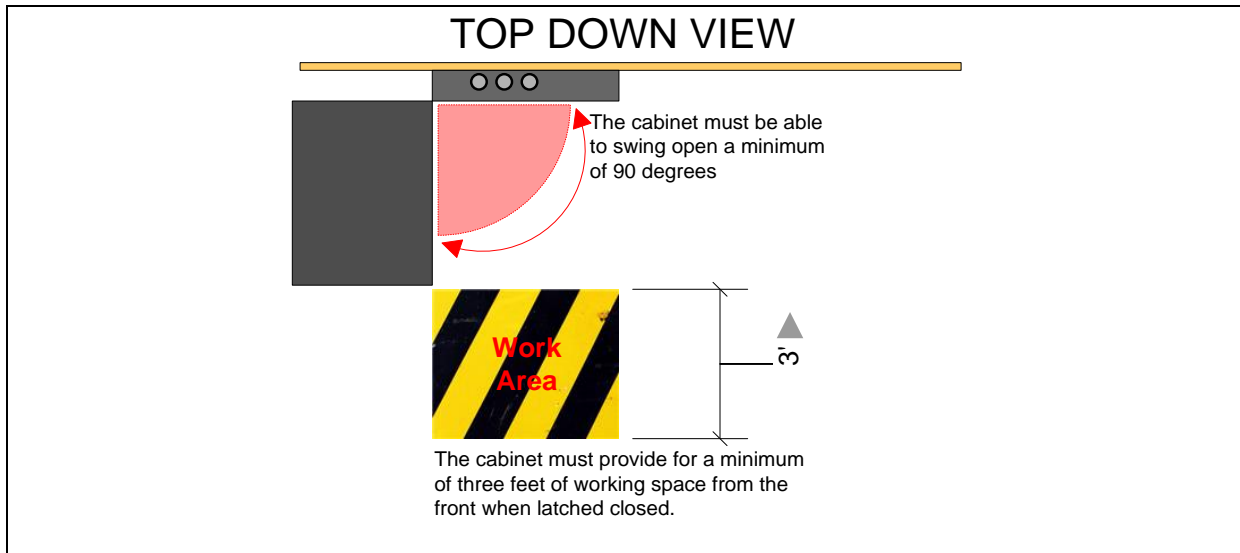

Figure 4-2 – IPDVS Server Cabinet Minimum Working Space

#### Minimum Working Space – IDF Cabinet

A minimum working space of three (3) feet from the front of the cabinet shall be available to allow the cabinet to swing fully open from its normal operating position.



**Figure 4-3 – IPDVS IDF Cabinet Minimum Working Space**

### Camera Placement

The following camera placement guidelines are to be followed for all IPDVS designs:

#### Exterior Cameras: Scenarios should be reviewed during design phase

1. Except where the mission of contributing to a safer environment would be compromised, outdoor cameras and their junction boxes shall not be installed at locations requiring the use of a lift vehicle to access the camera for service maintenance.
2. Wall and corner mounted cameras should be placed between fifteen (15) to eighteen (18) feet above ground level.
3. Except where alternative locations have been deemed less suitable, cameras designed to observe an entrance shall not be mounted directly above that entrance.
4. Parapet brackets must extend the full camera body beyond the far edge of the parapet. This includes and is **especially** important for corner locations; the entire camera body must extend beyond the vertex of the corner and have equal visibility along both faces of the building.
5. It is preferable to utilize a fixed position cameras rather than PTZs to monitor entrances.
6. PTZ cameras should preferably be installed as corner mount cameras or center distance on a wall between corners and avoid being mounted near the corners. Scenarios should be carefully reviewed during design phase.
7. A 4-way camera can be used externally and should always be corner-mounted with a 270-Degree field of view. (Lenses can be rotated to depict the 270° FoV). Scenario should be carefully reviewed during design phase.
8. Wall and corner mounted cameras should not be installed above a fence or similar structure that would place the camera within reach if the structure were climbed upon.
9. Except where installed to the lower surface of an overhang or on a parapet, all exterior cameras are to be mounted utilizing wall or corner mount brackets including the weather shield.

#### Interior Cameras: Scenarios should be reviewed during design phase

1. Corridor cameras shall not be installed in a “back to back” design that would create a blind spot directly beneath the two cameras. The cameras should be crisscrossed and at least 10 feet apart.
2. The 4-way camera needs to be installed ceiling mounted to capture 3 to 4 views. In a 4-way intersecting hallway scenario, each lens needs to be adjusted to capture each individual hallway. It's design offers 4 cameras in one.
3. In a 3-way intersecting hallway scenario, the three (3) lenses will capture 3 hallways and the 4<sup>th</sup> lens can be pointed downwards to capture view directly under the camera.
4. A Corner camera can be mounted in a 90-degree corner and provide a scenario where most blind spots are eliminated.
5. The short-throw camera is a single lens 180/360-degree field of view. In most cases, should be mounted in the center of a wall at a height of 10-12 feet.
6. Cameras located in the MDF rooms shall utilize wide-angle lenses, unless the configuration of the room and location of equipment is such that a standard lens would provide a more efficient field of view. In most MDF rooms, a wide-angle lens will provide a more complete coverage of the door and equipment racks than a standard lens.
7. Cameras covering stairwell landings shall utilize wide-angle lenses, unless the configuration of the stairway is such that a standard lens would provide a more efficient field of view. In most stairwells, a wide-angle lens will provide a more complete coverage of the vertical and horizontal spaces than a standard lens.
8. A small form factor PTZ camera can be used indoors in place of fixed domes in large areas where distance is a factor. Scenario should be reviewed during design.

## **Camera Numbering and Naming Guidelines**

### Camera Numbering

All cameras shall be numbered in a sequential manner beginning with 01, and increasing in increments of 1 for each additional camera installed, up to the maximum of 96 cameras per server. No numbers may be skipped in the sequence and no numbers may be duplicated. The camera numbering must not repeat beginning with camera 01 within entire site of the design.

### Camera Number Prefixes

The following are the approved camera numbering prefixes. All interior cameras shall begin their numbering prefix with the letter C. All exterior cameras shall begin their numbering prefix with the letter E.

C1 .....	Interior camera – First floor (Match number to floor number)
CA .....	Interior camera – Annex
CB .....	Interior camera – Basement
CC .....	Interior camera – Cellar
CG .....	Interior camera – Ground
CM .....	Interior camera – Mezzanine
CS .....	Interior camera – Sub-cellar
E1 .....	Exterior camera – Other than roof mount
ER .....	Exterior camera – Roof mount

## Camera Naming

The IPDVS camera names follow specific guidelines to communicate the maximum amount of information about the camera and the location it is observing. The name field is restricted to a total of fifty characters and must include these required items:

- Camera Number ..... Four (4) characters *followed by a space*
- Description of Field of View ..... Variable characters *followed by a space*
- PTZ Flag ..... Three (3) characters only if camera is a PTZ camera *followed by a space*
- Building ID ..... Four (4) characters (letter followed by three numbers)

The field of view descriptions should describe the area being observed and all descriptions within any building must be unique. For example multiple cameras in a cafeteria are not to be generically described as, "Cafeteria". A description such as, "NW Cafeteria corner viewing E" should be used with similar unique descriptive names for the other cameras.

To comply with New York City Department of Buildings Code and NYCDOE Policy:

1. Whenever cited, stairwells shall be identified by an alphabetic letter.
2. Whenever cited, exits shall be identified by a number

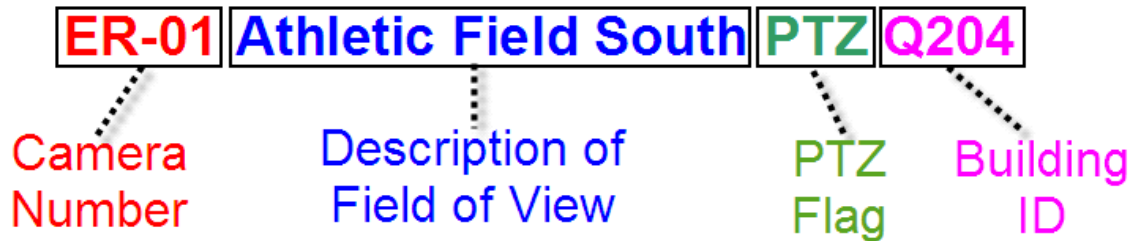

\*\* For Cameras such as the 180°/360° or 4-way cameras that display more views from a single camera, naming will be appended by A, B, C, etc. i.e Main view will be C1-01 followed by C1-01A, C1-01B, C1-01C, etc.

## Restricted Characters

For camera names, use only letters, numerals, dashes or underscores. The following characters must not be used in any portion of the full camera name.

- : Colon
- \ Back slash
- / Forward slash
- ; Semi-colon
- \* Asterisk
- ? Question mark
- ' Apostrophe
- < Less than
- > Greater than

| Vertical bar or "Pipe"  
" Quotation marks

### **Server Cabinet Location**

The IPDVS server shall always be placed in a seven (7) foot cabinet dedicated to IPDVS use. No IPDVS equipment may be installed in any existing LAN cabinet. There are three classifications of location where the IPDVS server cabinet may be installed. Whenever possible the IPDVS Server cabinet is to be installed in the building MDF. The IPDVS cabling and integration designs will vary depending upon the location of the IPDVS server.

#### Server Cabinet in Building MDF

This is the preferred IPDVS server cabinet location. When located in the MDF the IPDVS server shall be connected directly to the core switch with commercially manufactured patch cables.

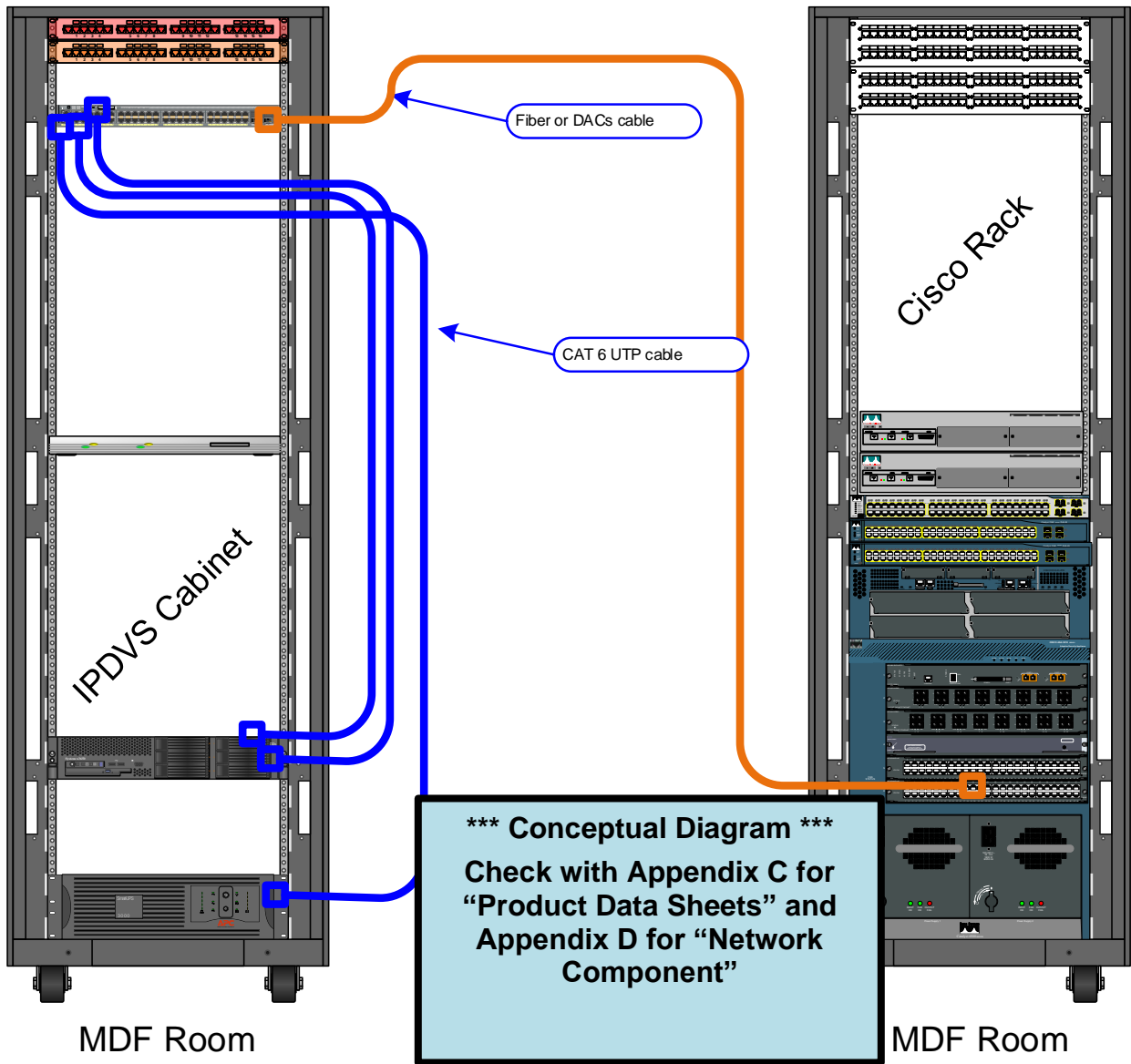

Figure 4-4 – Conceptual IPDVS Cabling Diagram

Server in IDF (less than 90 Meters/295 Feet of Core Switch)

When placement of the IPDVS server cabinet within the MDF is not an option, placement within an IDF with less than 90 meters/295 feet panel to panel Permanent Link distance to the core switch shall be performed. A Permanent Link horizontal cable segment shall be installed from the data patch panel of the IPDVS cabinet to a data patch panel in the MDF. Commercially manufactured patch cables will then be used to complete the channel link from the patch panel to the device.

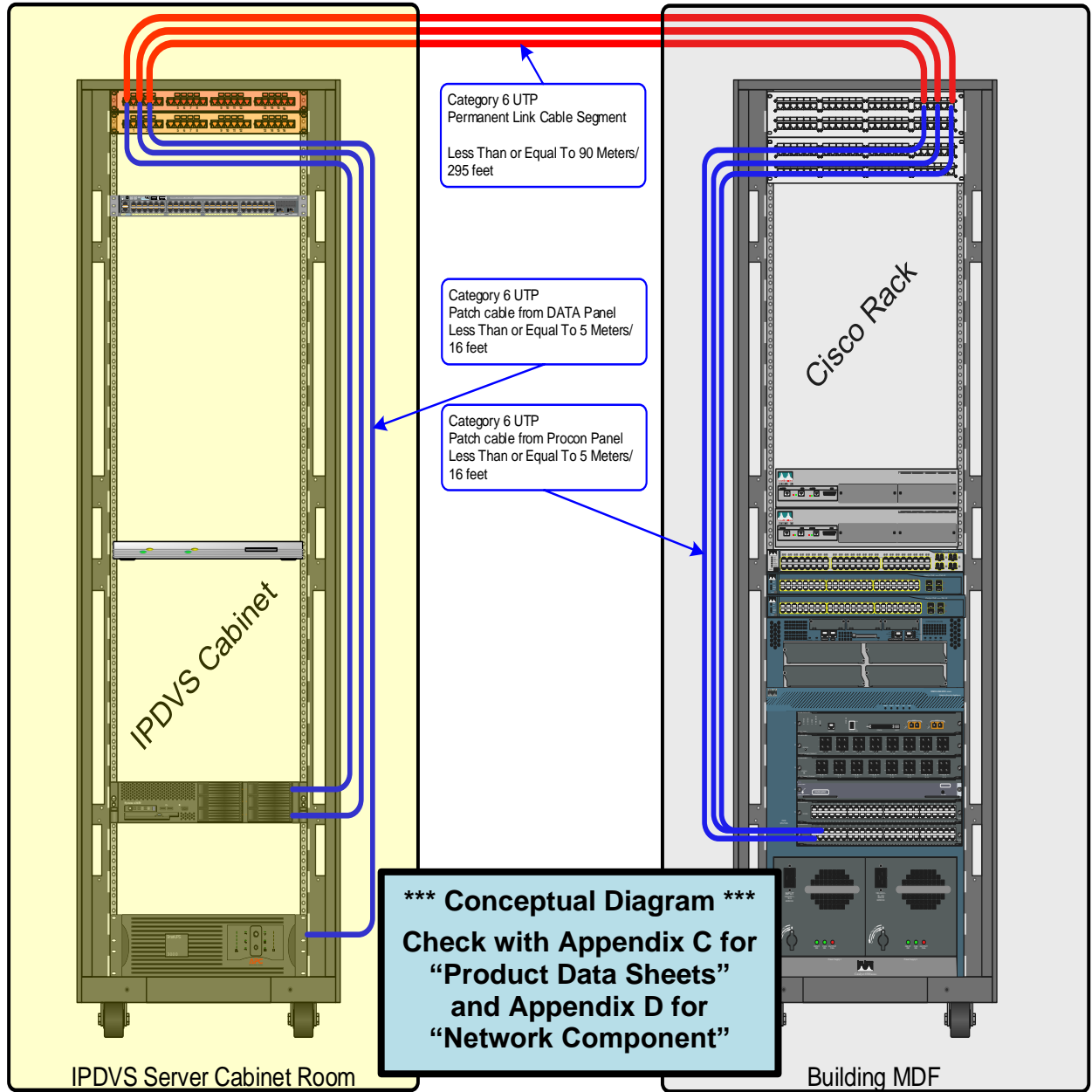

Figure 4-5 – Conceptual IPDVS Cabling Diagram

Server Cabinet in IDF (more than 100 Meters/328 Feet of Core Switch)

When placement of the IPDVS server cabinet either in the MDF or within 100 meters/328 feet channel distance of the core switch is not an option, the design described Figure 6 shall be followed. The IPDVS server must be placed within an IDF. If an IDF does not exist to house the server, a new IDF must be created. A fiber optic connection from the core switch to the edge switch in a LAN cabinet shall be created. The IPDVS server would then connect to the edge switch with commercially manufactured patch cables.

**Note:** This connectivity method requires approval from DIIT QA & Engineering Support group prior to design submission from the SI.

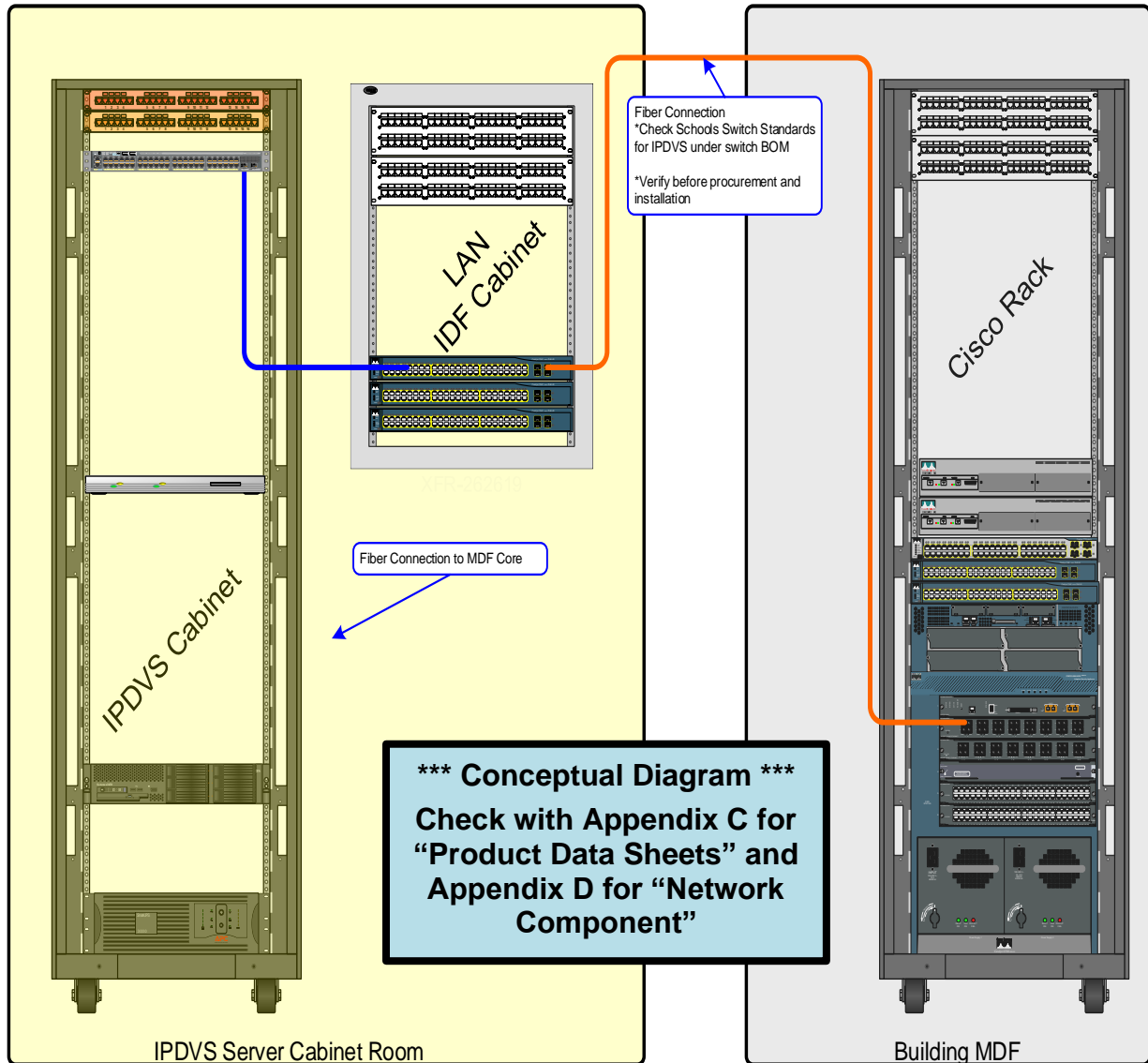

Figure 4-6 – Conceptual IPDVS Cabling Diagram

### Location of Main Viewing Station

#### Standard Console

IPDVS installations shall include the provision of a dedicated main viewing station (MVS) in the lobby for use by School Safety Agents. Dedicated viewing consoles for use of the School Safety Agents require planning beyond the viewing requirements of a typical school administrative user.

MVS displays located in a lobby or similar main entrance space shall be enclosed within console cabinetry, featuring a secure dual display capable protective enclosure. Monitors may not be mounted on walls or other locations that are easily viewable by the public.

1. For capital improvement program projects, the console shall be the current approved model as described in Appendix-A.
2. For capacity projects, a custom millwork console may be substituted provided the designer follows the guidelines outlined in SCA Specification 16783.

Power outlets and data jacks for viewing consoles are to be extended inside the console and enclosed in either rigid or flexible metallic conduit. Outlet boxes and network boxes are to be rigidly mounted within the console cabinetry at locations that do not interfere with the operation of any door or sliding shelf, including equipment that may be placed upon sliding shelves. Care shall be taken to ensure the cabling does not present a trip or crush hazard.

#### Alternatives to the Standard Console

In some school buildings there is insufficient space to install a standard console in the lobby without blocking egress. In the event there is insufficient lobby floor space to safely install, a smaller-form factor console. Refer to Appendix-A for options.

If the lobby space constraints preclude the installation of any stationary furniture, then a customized computer rolling cart from Datamation Systems, Inc. DS-3518-GMQ-T-2M-MK may be deployed. The school principal(s) must agree in advance to take responsibility for assigning staff to setup the MVS equipment cart each morning and secure the MVS equipment cart each afternoon.

Only in cases where neither a console nor a rolling cart is feasible, the MVS equipment may be installed in a secure office location. No console cabinetry is needed when the MVS is placed inside an office.

#### **Public Notification of Video Surveillance**

Schools with video surveillance equipment should prominently post warning notices at the entrance(s) to the building. All buildings participating in the Internet Protocol Digital Video Surveillance (IPDVS) program are provided Fiberglass signs with the following wording:

*“NOTICE: THIS BUILDING IS UNDER VIDEO SURVEILLANCE THAT MAY BE MONITORED AND/OR RECORDED AT ANY TIME.”*

### ***Electrical and General Contracting***

#### **Low Voltage Data Cabling / Electrical**

NYCDOE is committed to providing a high bandwidth backbone in each building and school. All new cabling in buildings and schools must adhere to the latest specification of requirements for voice and data cabling published by the DIIT. To a great extent, these standards conform to the ANSI TIA/EIA-568-B documents.

All data and video cabling shall be installed in accordance with specifications found in the latest addendum to the ANSI/TIA/EIA Standard entitled "Commercial Building Telecommunications Cabling Standard", TIA/EIA-568-B and all relevant addenda. DIIT requires that all components including cable, connectors, outlets and patch cords meet or exceed applicable performance standards adopted by the TIA/EIA.

Tests of UTP cable shall be conducted with Level II-E Field Test Equipment (FTE). Testing equipment should be calibrated within 1 year of the data-cabling install as specified in Industry Standards, to maintain confidence and integrity of results. Any cable run not passing Category 6 requirements must be repaired, or replaced, and then re-tested for compliance.

TIA/EIA-568-B cable distance lengths are 100 meters/328 feet max to complete a “link” or “end to end” “channel” distance, inclusive of video outlets (jacks), patch panels (cords), and connector plugs. “Link” distance is defined as a single cable run maximum of 90 meters/295 feet. “Channel” distance is defined as a maximum of 100 meters/328 feet “end to end” between equipment. “End to end” is defined as end-to-end transmission between two points at which application-specific equipment is connected.

Example: The channel distance in the IPDVS scenario would be a maximum of 100 meters/328 feet, camera to switch inclusive of video outlets (jacks), patch panels (cords), and connector plugs. Any distance less or equal to this will be accepted as compliant.

### General

The following general low voltage cabling requirements shall apply to all IPDVS low voltage cabling.

1. All IPDVS cable, patch panels, patch cables and jacks shall meet or exceed EIA/TIA Category-6 Specifications.
2. All cables must be approved by the Underwriters Laboratories, Inc. and must bear exterior jacket markings indicating type, category classification if applicable, fire rating of jacket material, number of conductors/strands, and conductor gauge.
3. Patch panels are to be completely populated with jacks at the time of installation.
4. No “Home Run” type cabling shall be accepted.
  - a. All telecommunication closet side terminations of permanent link cable segments shall terminate to a patch panel. No loose jacks shall be acceptable.
  - b. All station (camera or workstation) side terminations of permanent link cable segments shall terminate to a Category-6 female jack. The Cat6 jacks shall be mounted in a faceplate for workstations or a biscuit jack within the camera interface enclosure box for cameras.
5. These standards are in agreement with:
  - a. *DIIT Voice/Data Cable Infrastructure Specifications*
    - i. If any disagreement is found among the documents, the contractually binding document the job is being performed under shall hold precedence.
  - b. *SCA Specification 16783 - (IPDVS) USING ANALOG CAMERAS (CAPACITY ADDITION PROJECTS)*
    - i. If any disagreement is found among the documents, the contractually binding document the job is being performed under shall hold precedence.
  - c. *SCA Specification 16785 - (IPDVS) SYSTEM USING DIGITAL CAMERAS (CAPACITY PROJECTS)*
    - i. If any disagreement is found among the documents, the contractually binding document the job is being performed under shall hold precedence.
  - d. *SCA Specification 16786 - (IPDVS) CABLING SYSTEM USING DIGITAL CAMERAS (CAPITAL IMPROVEMENT PROJECTS)*
    - i. If any disagreement is found among the documents, the contractually binding document the job is being performed under shall hold precedence.
  - e. *SCA Specification 16727 – Data Cabling System*
    - i. If any disagreement is found among the documents, the contractually binding document the job is being performed under shall hold precedence

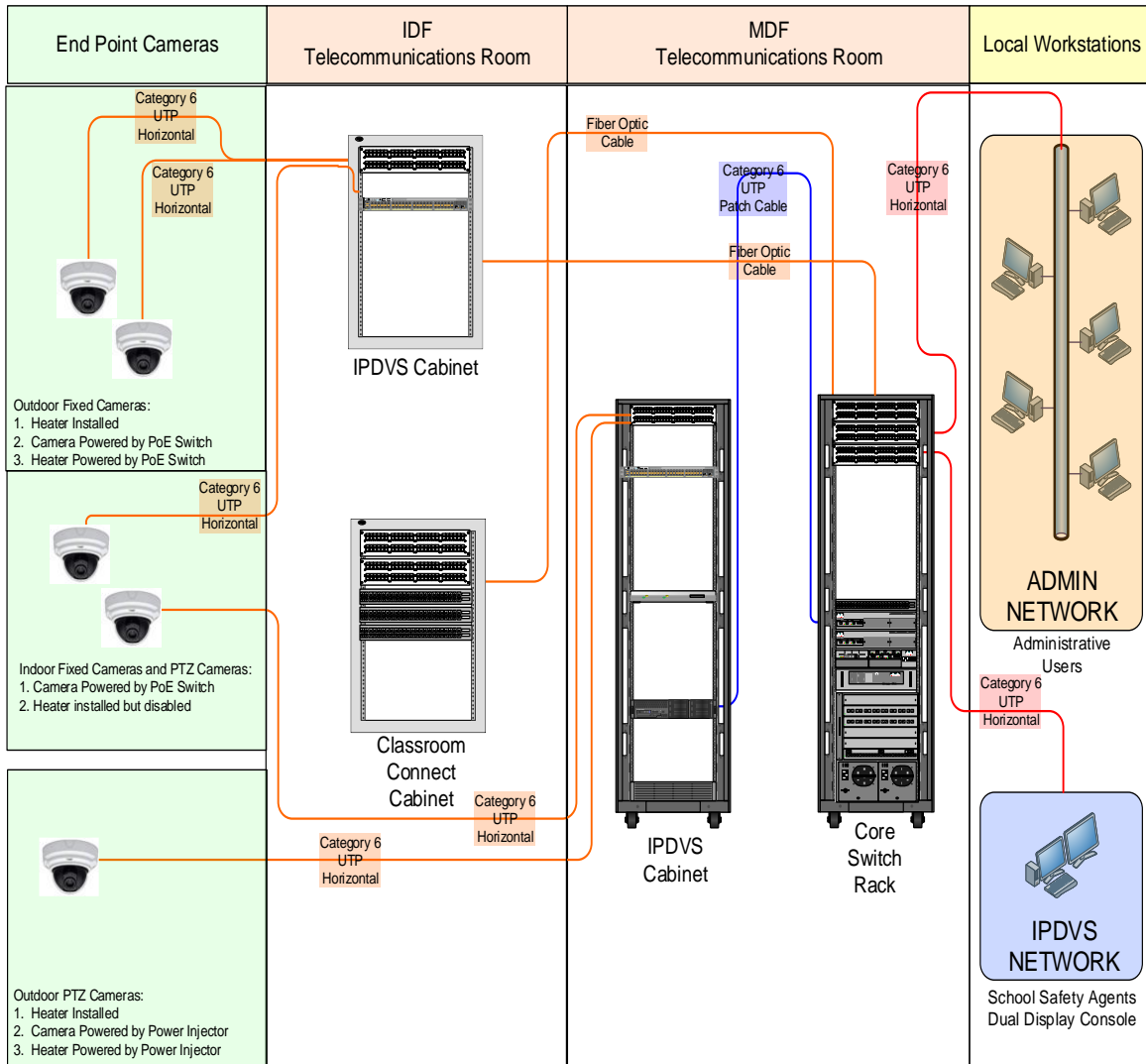

Figure 4-7 – Conceptual IPDVS Cabling Diagram

**\*\*\* Conceptual Diagram \*\*\***  
**Check with Appendix C**  
**for “Product Data Sheets”**  
**and Appendix D for**  
**“Network Component”**

Cable and Jack Color Coding

The following color coding shall be followed for Video and Data cabling:

1. Cable and jack inserts used for video transmission shall be orange (Pantone 150C) in color. Jack inserts used for data transmission faceplates and patch panels shall be red (Pantone 184C) in color.

2. Data and Video Separation of Patch Panels Data and video cabling shall not be terminated on the same patch panel. In all IPDVS cabinets the uppermost RU position shall contain a 1U patch panel dedicated for data cabling connections. No cameras shall be terminated to this patch panel.
3. In all IPDVS cabinets, the lower RU positions, as needed, shall contain patch panels dedicated to video connections. No data connections shall be terminated to these panel(s).

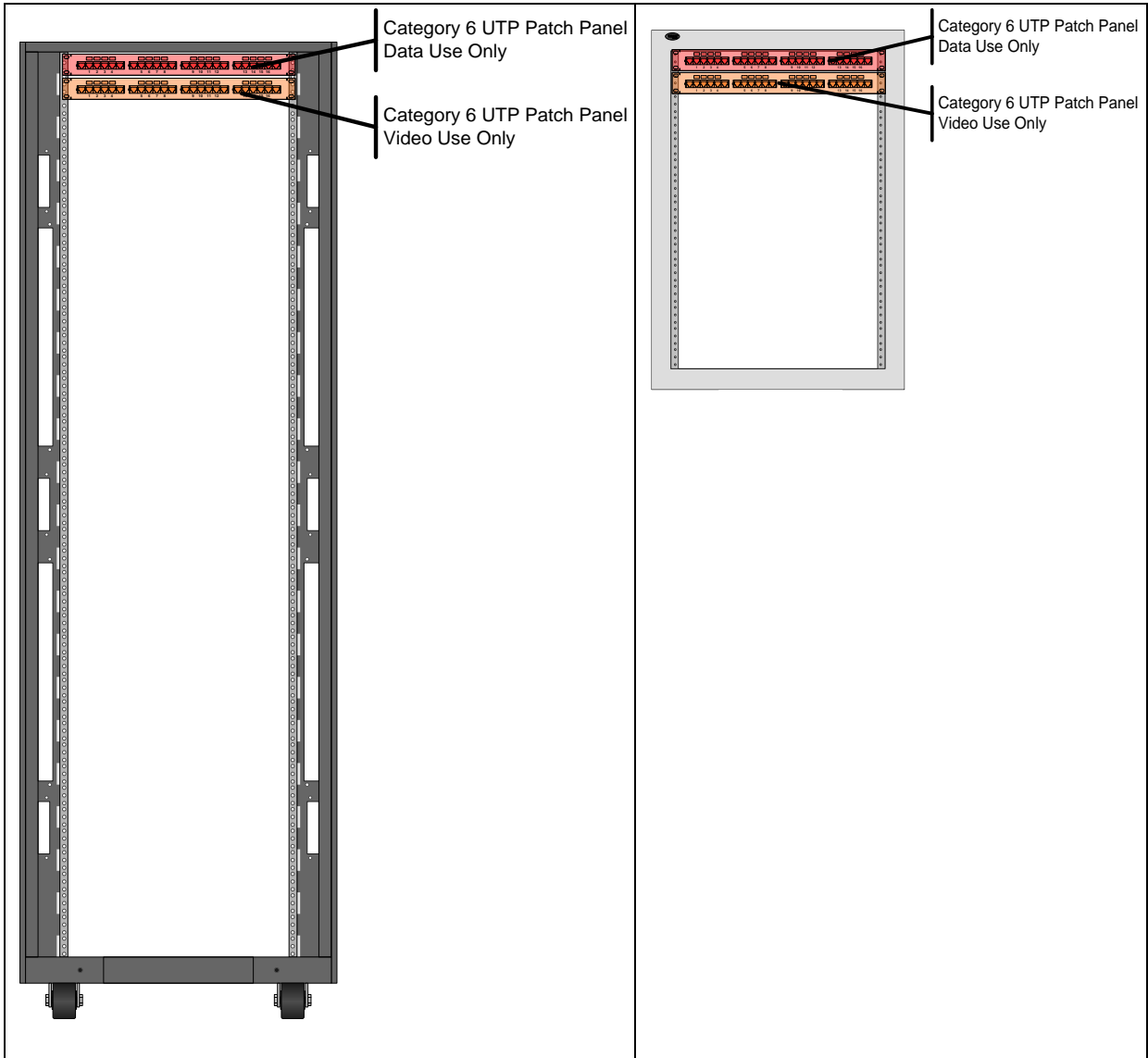

Figure 4-8 – IPDVS Cabinet Patch Panel Placement

### Camera Cabling

This section demonstrates the cabling and connection methods to be followed for cabling cameras in the IDPVS program.

There are four basic camera locations, each with its unique cabling requirements. These are:

1. Indoor Fixed Position Camera
2. Outdoor Fixed Position Camera

3. Indoor PTZ Camera
4. Outdoor PTZ Camera

Indoor/Outdoor Fixed Position Camera

Camera Cable ..... Orange Cat6

MDF/IDF Side Termination ..... Cat6 Patch Panel Port

Camera Side Termination ..... Cat6 Female Jack in Single Port Commscope Modular punchdown jack located in Eaton Condulet outlet body

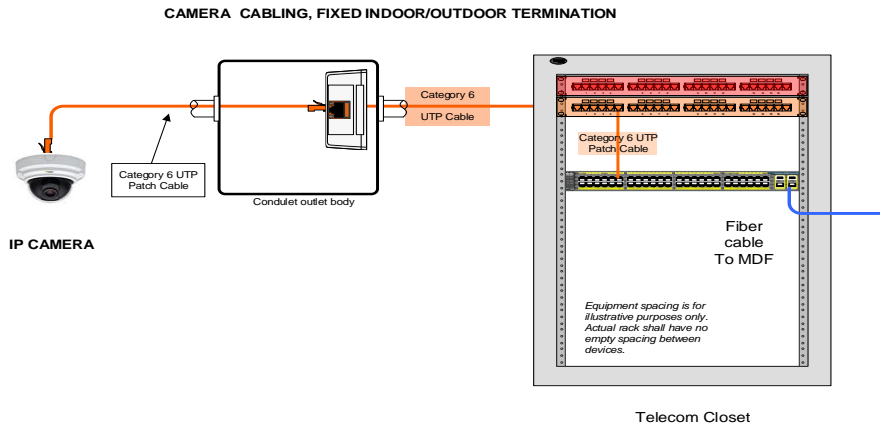

Figure 4-9 – Indoor/Outdoor Fixed Position Cabling Diagram

Indoor/Outdoor PTZ Camera

Camera Cable ..... Orange Cat6

MDF/IDF Side Termination ..... Cat6 Patch Panel Port

Camera Side Termination ..... Cat6 Female Jack in Single Port Commscope Modular punchdown jack located in Eaton Condulet outlet body

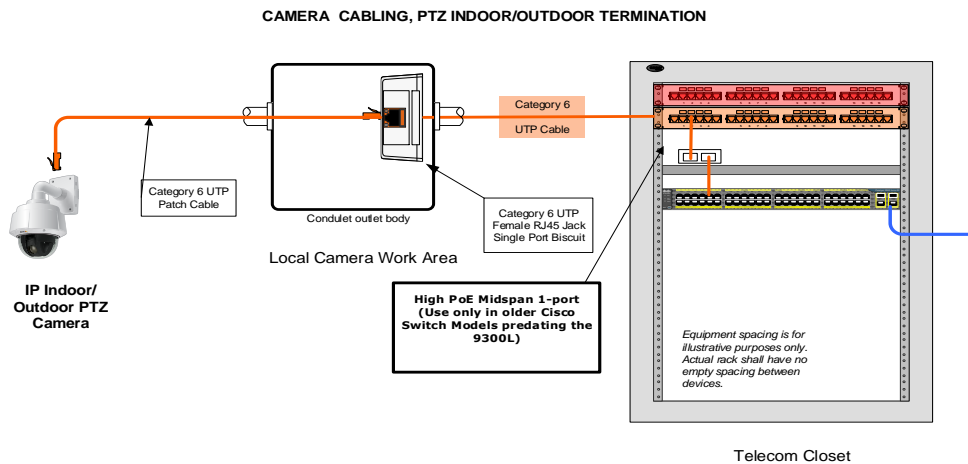

Figure 4-10 – Indoor/Outdoor PTZ Cabling Diagram

## Data Cabling

All IPDVS data cabling shall be governed by the *School Networking and Telecommunications* (Section 2 of this document). The following specific items are governed by the *DIIT Standards for IPDVS*.

### No “Dedicated” Cabling Permitted Directly between Camera and Switch

For purposes of this document, Dedicated Cabling is defined as a single contiguous cable that completes the full Channel Link between a telecommunications closet and a station side camera or workstation. In some technical forums this is also known as “Home Run Cabling” which is not an acceptable practice for IPDVS.

1. All IPDVS data cables entering a telecommunications closet must terminate on a patch panel inside a cabinet.
  - a. No loose data jacks are permitted in or on the IPDVS or LAN telecommunications cabinets.
  - b. No ‘biscuit’ jacks are permitted in or on the IPDVS or LAN telecommunications cabinets.
2. Patch cables, commercially manufactured or otherwise, may not be run between rooms.
  - a. Commercially manufactured patch cables are acceptable to interconnect devices between IPDVS and LAN cabinets provided both cabinets are within the same room with proper cable management. Cables shall be installed in a neat and efficient manner and contained within D-rings or upon ladder-rack being secured with fire resistance hook and loop fastener material every two (2) feet vertically and four (4) feet horizontally.

## Low Voltage Cable Labeling

### General Labeling

All camera, work area and MDF/IDF terminations must be labeled and clearly identified utilizing designation strips in compliance with the EIA/TIA 606 standards. A permanent-labeling machine, compliant with TIA/EIA 606 labeling standards must be used.

### Video Cable Labeling – Cable Wrap and Patch Panel Port Labels

Labels shall be applied as follows:

#### Location

#### Label Data

1. Camera cable cable-jacket behind patch panel ..... Camera Number
2. Camera cable cable-jacket inside camera conduit body ..... MDF/IDF Room# - Camera Number
3. Patch Panel jack ..... Camera Number

**Table 4.1: Sample Video Cable Wrap and Patch Panel Port Labels**

C1-22	255 - C1-22	C1-22
-------	-------------	-------

Sample cable wrap label placed on Cat6 video cable behind patch panel termination.  Example used is first floor camera number 22.	Sample cable wrap label placed on Cat6 video cable inside camera side quad box.  Example used is first floor camera number 22 terminating in room 255.	Sample Patch panel label placed on Cat6 patch panel port where video cable terminates.  Example used is first floor camera number 22.
-----------------------------------------------------------------------------------------------------------------------------------------	--------------------------------------------------------------------------------------------------------------------------------------------------------------	---------------------------------------------------------------------------------------------------------------------------------------------

Data Cable Labeling – Telecommunications Closet (TC) to TC Labels

This section specifically addresses IPDVS data cabling between an IPDVS cabinet located in one room and a LAN cabinet located in another. Same room cabinets are assumed to be connected via patch cables without a permanent link cable segment interconnecting patch panels in each cabinet.

IPDVS Server Room to LAN Telecommunications Closet (MDF or IDF) Labeling

When the IPDVS server is located in a room without a LAN cabinet, a switch will be installed in the IPDVS cabinet and fiber link segment will run to the core switch in the MDF room. If IPDVS server cabinet is located near a LAN cabinet additional data cables can be run between the two cabinets at a rate of one data cable per camera or device terminating in the IPDVS server cabinet. When surveying a site, please check with DIIT QA & Engineering support group for guidance when encountering scenarios that are inconsistent with best practices.

The cable-wrap and patch panel port labels for these data runs are listed below. Each label shall contain two pieces of information separated by a dash. These are the room number at the far end of the cable where the termination is made to the LAN cabinet patch panel and an alpha-numeric drop ID per the table below. The additional data cables shall begin their numbering at “D1” and increase sequentially to “D2”, “D3”, etc. for each cable installed.

IPDVS Server Cabinet Data Patch Panel Port Label

- Port-1 ..... <LAN Cabinet Room#> - DVS-S1
- Port-2 ..... <LAN Cabinet Room#> - DVS-R1
- Port-3 ..... <LAN Cabinet Room#> - DVS-U1
- Port-4 ..... <LAN Cabinet Room#> - DVS-S2
- Port-5 ..... <LAN Cabinet Room#> - DVS-R2
- Port-6 ..... <LAN Cabinet Room#> - DVS-U2
- Port-7 ..... <LAN Cabinet Room#> - DVS-D1
- Port-8 ..... <LAN Cabinet Room#> - DVS-D2

LAN Cabinet Data Patch Panel Port Label

- Port-x ..... <IPDVS Cabinet Room#> - DVS-S1
- Port-x ..... <IPDVS Cabinet Room#> - DVS-R1
- Port-x ..... <IPDVS Cabinet Room#> - DVS-U1
- Port-x ..... <IPDVS Cabinet Room#> - DVS-S2
- Port-x ..... <IPDVS Cabinet Room#> - DVS-R2

Port-x ..... <IPDVS Cabinet Room#> - DVS-U2  
 Port-x ..... <IPDVS Cabinet Room#> - DVS-D1  
 Port-x ..... <IPDVS Cabinet Room#> - DVS-D2

**Note:** Any available patch panel ports in the LAN cabinet may be used, so port numbers are not specified.

Device	Label Contents Description and Placement
Patch Panel for SSA Console(s)	Work Area room# where cable jack is located for this Workstation <dash> SSA# <b>Use SSA1</b> for first SSA console. <b>Use SSA2</b> for second SSA console. <b>Use SSA3</b> for third SSA console.
IPDVS Server(s)	Use <b>DVS-S1</b> for the primary IPDVS server NIC interface. Use <b>DVS-R1</b> for the primary IPDVS server IMM interface. Use <b>DVS-S2</b> for the optional second IPDVS server NIC interface. Use <b>DVS-R2</b> for the optional second IPDVS server IMM interface.
UPS(s)	Use <b>DVS-U1</b> for the primary UPS management interface. Use <b>DVS-U2</b> for the secondary UPS management interface.
Data Patch Cable	Use <b>DVS-D1</b> for data patch cable or fiber data link segment. Use <b>DVS-D2</b> for the secondary patch cable or fiber link segment.

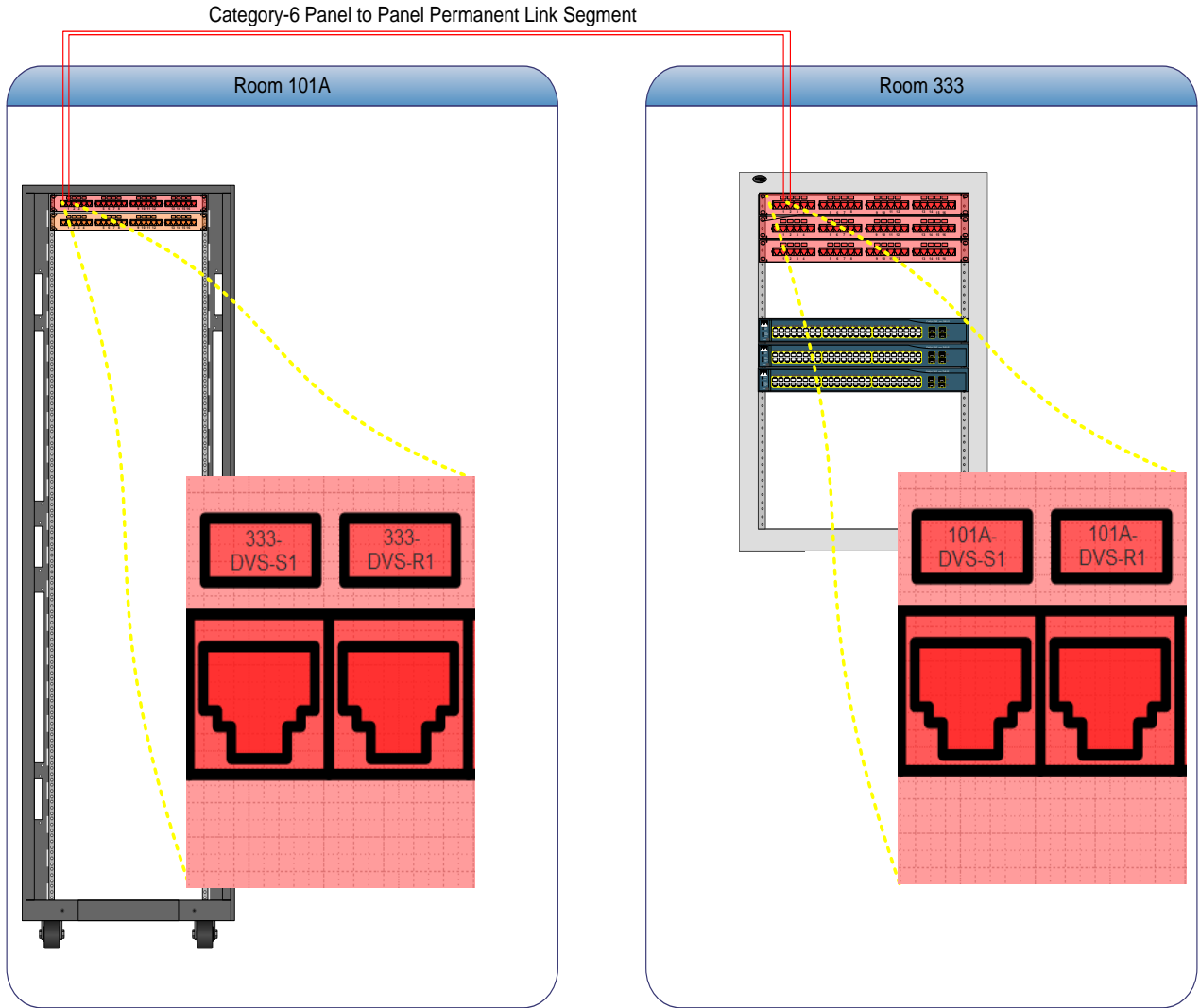

Figure 4-11 - Sample Labeling: IPDVS Server Cabinet Patch Panel to LAN Cabinet Patch Panel

IPDVS IDF to LAN Telecommunications Closet (MDF or IDF) Labeling

When an IPDVS IDF cabinet is located in a room without a LAN cabinet, permanent link data cabling will be run from the IPDVS cabinet to the LAN cabinet at a rate of one data cable per every sixteen cameras that terminate in the IPDVS IDF.

IPDVS IDF Cabinet Data Patch Panel Port	Label
Port-1 .....	<LAN Cabinet Room#> - DVS-D1
Port-2 .....	<LAN Cabinet Room#> - DVS-D2

LAN Cabinet Data Patch Panel Port	Label
Port-x .....	<IPDVS IDF Cabinet Room#> - DVS-D1
Port-x .....	<IPDVS IDF Cabinet Room#> - DVS-D2

**Note:** Any available patch panel ports in the LAN cabinet may be used so port numbers are not specified.

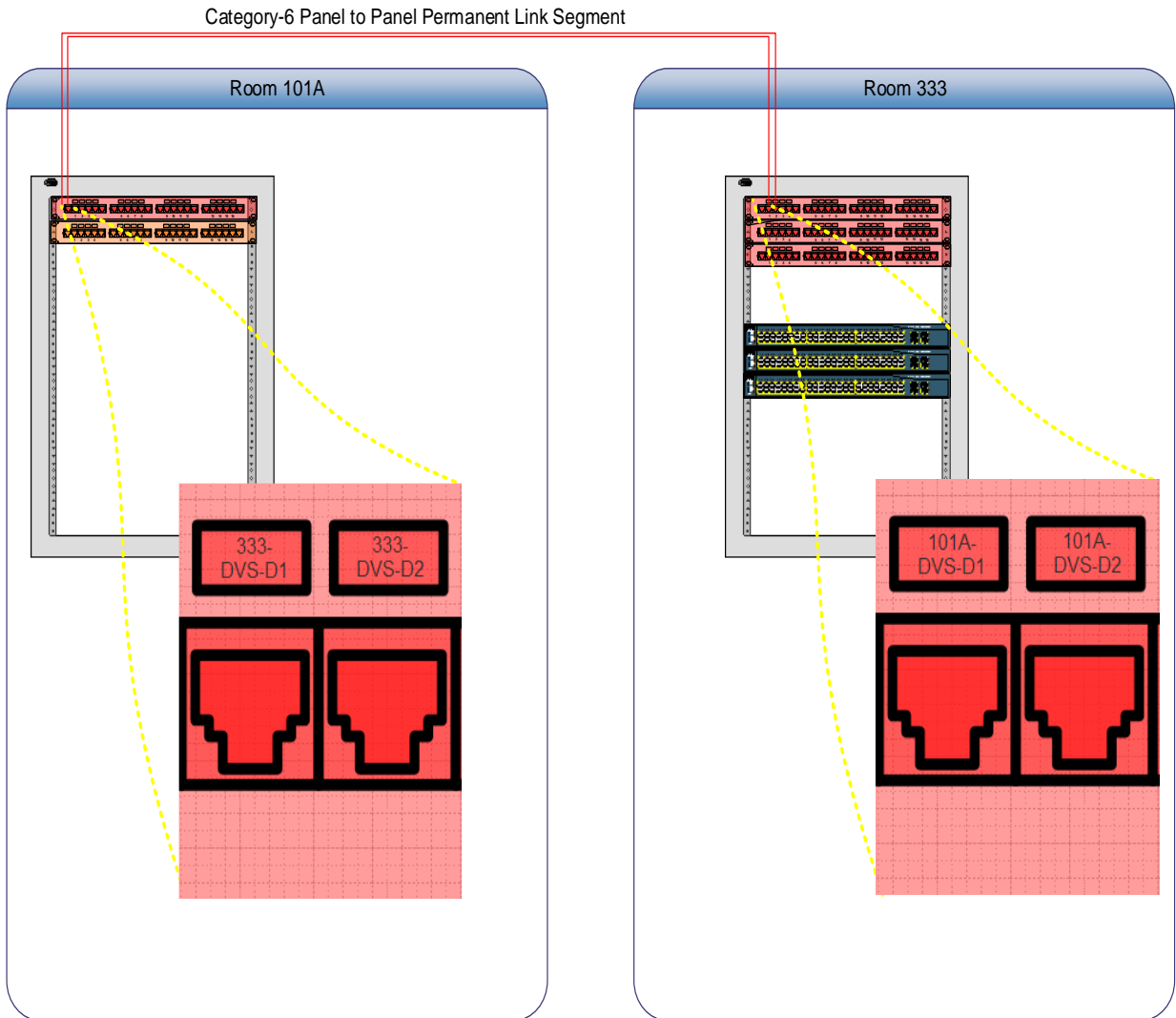

**Figure 4-12 - Sample Labeling: IPDVS IDF Patch Panel to LAN Cabinet Patch Panel**

Data Cable Labeling – Telecommunications Closet to Station Faceplate Labeling

The IPDVS program installs a single workstation data drop for the MVS. All other station cabling that may be installed during the IPDVS project shall follow the labeling requirements listed in the current version of the DIIT Voice/Data Cable Infrastructure Specifications.

Location	Label Data
1. Data cable cable-jacket behind patch panel .....	<Station Side Room#> - SSA1
2. Patch panel jack .....	<Station Side Room#> - SSA1
3. Station side data cable cable-jacket inside station side box .....	<LAN Cabinet Room#> - SSA1
4. Station side faceplate .....	<LAN Cabinet Room#> - SSA1

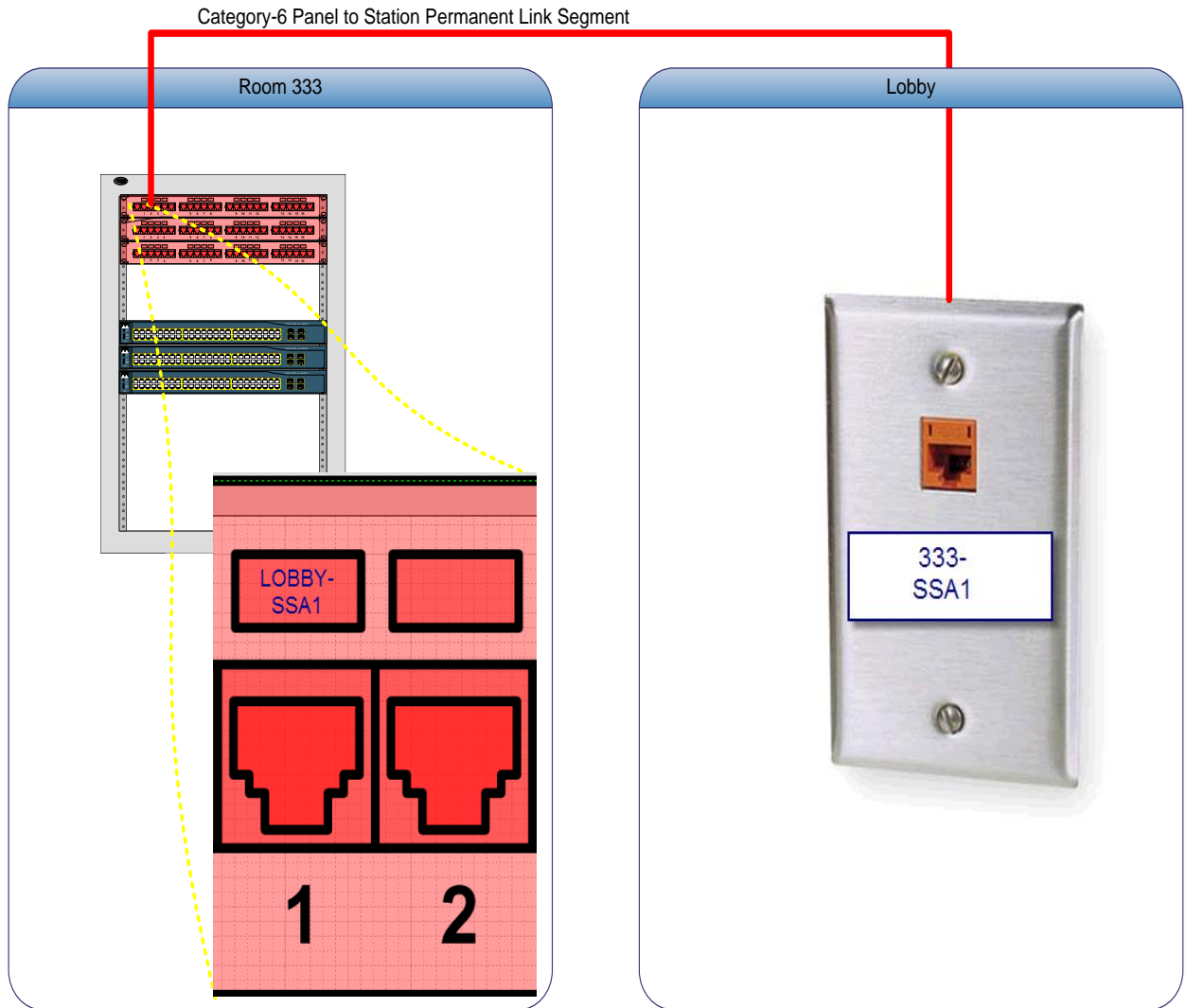

Figure 4-13 – Sample Labeling: Patch Panel to Workstation Faceplate

## High Voltage Electrical

### General

The appropriate electrical power must be provided to IPDVS cabinet locations. The IPDVS circuits must be dedicated for the sole use of IPDVS equipment. Existing branch circuits may not be used except for the (MVS) location unless the existing branch circuit is already at capacity. The IPDVS dedicated circuits may not be extended to other areas or used for any other purposes.

At locations where permanently affixed ladder rack exists, the quadruplex boxes may be affixed to the ladder rack directly above the IPDVS cabinet no higher than one foot above the IPDVS cabinet. This should always be the case in newly constructed buildings. Electrical cabling to the quadruplex boxes shall be installed along the ladder rack in Galvanized Rigid Conduit (GRC) or Electric Metallic Tubing (EMT) and shall be in compliance with SCA Specification 16130.

At some locations there may not be a permanently affixed ladder rack. This may be the case in CIP projects for existing buildings. In these situations, the quadruplex boxes shall be installed inside the IPDVS server cabinet.

MDF Cabinet Power

The MDF receptacle locations may differ for capital improvement installations versus capacity installations. Under no circumstances shall receptacles be installed on or recessed into the MDF floor for any installation type.

Circuit 1: Primary Server UPS Power

Voltage Rating .....	120 Volt
Current Rating .....	30 Amp
Breaker Rating .....	30 Amp
Dedicated Circuit .....	Yes
Isolated Ground .....	Not Required
Receptacle Type .....	NEMA L5-30R
Receptacle Count .....	1 Outlet
Receptacle Label .....	<Panel ID> - <Breaker #>
Panel Label at Breaker Position .....	"IPDVS Critical Power"
Recommended Breaker Schedule Card Description .....	"IPDVS MDF Cabinet 30A"

Circuit 2: Primary Device Power

Voltage Rating .....	120 Volt
Current Rating .....	20 Amp
Breaker Rating .....	20 Amp
Dedicated Circuit .....	Yes
Isolated Ground .....	Not Required
Receptacle Type .....	NEMA 5-20R
Receptacle Count .....	1 Quadruplex (4 outlets total)
Receptacle Label .....	<Panel ID> - <Breaker #>
Panel Label at Breaker Position .....	"IPDVS Critical Power"
Recommended Breaker Schedule Card Description .....	"IPDVS MDF Cabinet 20A"

Circuit 3: Auxiliary Device Power

Voltage Rating .....	120 Volt
Current Rating .....	20 Amp
Breaker Rating .....	20 Amp
Dedicated Circuit .....	Yes
Isolated Ground .....	Not Required
Receptacle Type .....	NEMA 5-20R
Receptacle Count .....	1 Quadruplex (4 outlets total)
Receptacle Label .....	<Panel ID> - <Breaker #>
Panel Label at Breaker Position .....	"IPDVS Critical Power"
Recommended Breaker Schedule Card Description .....	"IPDVS MDF Cabinet 20A"

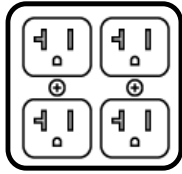

**Dedicated IPDVS Circuit 2**  
**20 Amp, 120V**  
**NEMA 5-20R**  
**Quadruplex Box**

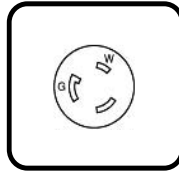

**Dedicated IPDVS Circuit 1**  
**30 Amp, 120V**  
**NEMA L5-30R**  
**Twist-Lock Receptacle Box**

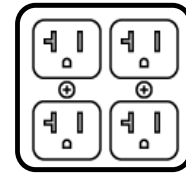

**Dedicated IPDVS Circuit 3**  
**20 Amp, 120V**  
**NEMA 5-20R**  
**Quadruplex Box**

**Figure 4-14 – IPDVS Server Cabinet Receptacles**

**IPDVS Capital Improvement Installation Receptacle Locations**

The electrical receptacles at capital improvement installations are mounted within the IPDVS cabinet. The electrical cabling shall be enclosed in Flexible Metallic Conduit (FMC) between the cabinet receptacle boxes and the wall or ladder rack mounted junction box. The FMC must provide sufficient service length for the cabinet to move three (3) feet in any direction from its normal operating location.

**IPDVS Capacity Installation Receptacle Locations**

The receptacles for capacity installations may be mounted inside the cabinet as with capital improvement installations or may also acceptably be mounted:

1. On ladder-rack directly above the IPDVS cabinet.
2. On the wall directly behind the IPDVS cabinet.

If the receptacles are installed within the cabinet the electrical cabling shall be enclosed in FMC between the cabinet receptacle boxes and the wall or ladder rack mounted junction box. The FMC must provide sufficient service length for the cabinet to move three (3) feet in any direction from its normal operating location.

**Electrical Receptacle Faceplate Labeling**

All electrical receptacles installed for IPDVS use must be labeled with two pieces of information:

1. The electrical panel identification placard where the circuit's over-current protection device is located
2. The circuit number of the breaker position energizing the receptacle.

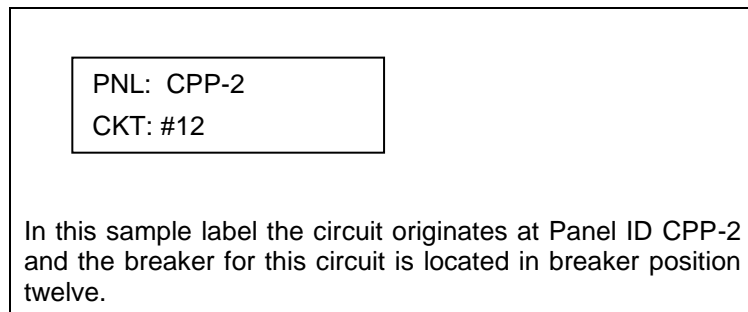

**Figure 4-15 – Sample Electrical Receptacle Label**

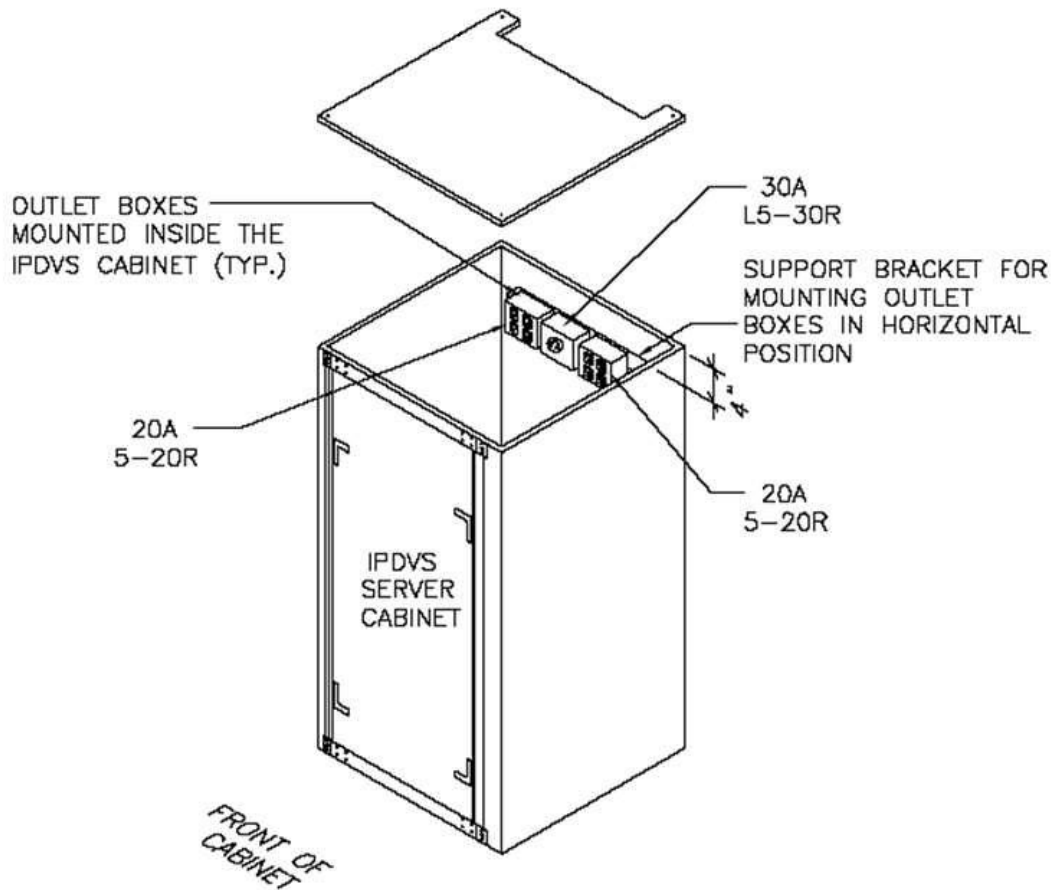

Figure 4-16 – IPDVS Server Cabinet Location of Electrical Receptacles

IDF Cabinet Power

The IDF electrical requirements are the same for both capacity and capital improvement job types. Each IDF will require 2 Dedicated - 20A circuits dedicated for IPDVS use. The receptacle boxes are to be installed upon the back board inside the IPDVS IDF cabinet.

Circuit 1: Device Power

Voltage Rating .....	120 Volt
Current Rating .....	20 Amp
Breaker Rating .....	20 Amp
Dedicated Circuit .....	Yes
Isolated Ground .....	Not Required
Receptacle Type .....	NEMA 5-20R
Receptacle Count .....	2 Quadruplex (8 outlets total)
Receptacle Label .....	<Panel ID> - <Breaker #>
Panel Label at Breaker Position .....	"IPDVS Critical Power"
Recommended Breaker Schedule Card Description .....	"IPDVS IDF Cabinet 20A"

Circuit 2: Device Power

Voltage Rating .....	120 Volt
Current Rating .....	20 Amp
Breaker Rating .....	20 Amp
Dedicated Circuit .....	Yes
Isolated Ground .....	Not Required
Receptacle Type .....	NEMA 5-20R
Receptacle Count .....	2 Quadruplex (8 outlets total)
Receptacle Label .....	<Panel ID> - <Breaker #>
Panel Label at Breaker Position .....	"IPDVS Critical Power"
Recommended Breaker Schedule Card Description .....	"IPDVS IDF Cabinet 20A"

	
<p><b>Dedicated IPDVS Circuit 1</b>  <b>20 Amp, 125V, 2,400 Watts</b>  <b>NEMA 5-20R x 4</b>  <b>QUAD Box</b></p>	<p><b>Dedicated IPDVS Circuit 2</b>  <b>20 Amp, 125V, 2,400 Watts</b>  <b>NEMA 5-20R x 4</b>  <b>QUAD Box</b></p>

Figure 4-17 - IPDVS IDF Cabinet Receptacles

Power for Console Cabinetry

The IPDVS Console may be connected to any branch circuit with sufficient amp capacity.

**Cabinet Grounding**

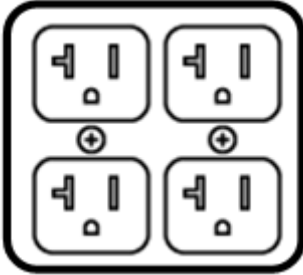
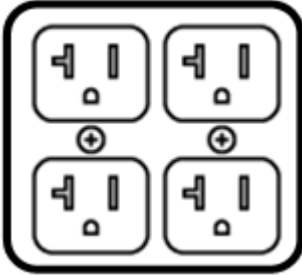
Equipment shall be grounded in accordance with ANSI/TIA/EIA-607 and the NEC, including Article 800. All communications cabinets and racks at the Main Telecommunications Room and Intermediate Telecommunications Room must be grounded to a common earth ground with a minimum #6 AWG stranded copper line. Telecommunications Ground Busbar must be installed in each IDF/MDF.

IPDVS racks/cabinets must be grounded in accordance with manufacturer's specifications. A #6 AWG stranded copper conductor shall connect the cabinet manufacturer's specified ground connection point to the grounding Busbar within the MDF/IDF.

Additional Reference

Division 16 Specification 16450 – Grounding and Bonding

### MDF Cabinet

Connect the IPDVS server cabinet to the grounding Busbar with #6 AWG stranded copper conductor routed along shortest and straightest paths possible, unless otherwise indicated. Avoid obstructing access or placing conductors where they may be subjected to strain, impact, or damage. Connect conductor to the cabinet manufacturer's specified grounding connection point(s).

**Note:** APC cabinets have multiple grounding points. Check with the manufacturer's instructions

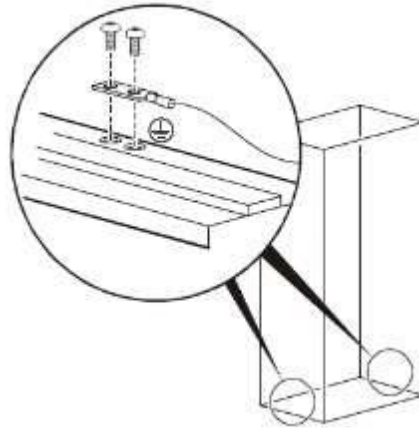

Figure 4-18 – APC Cabinet Ground Location

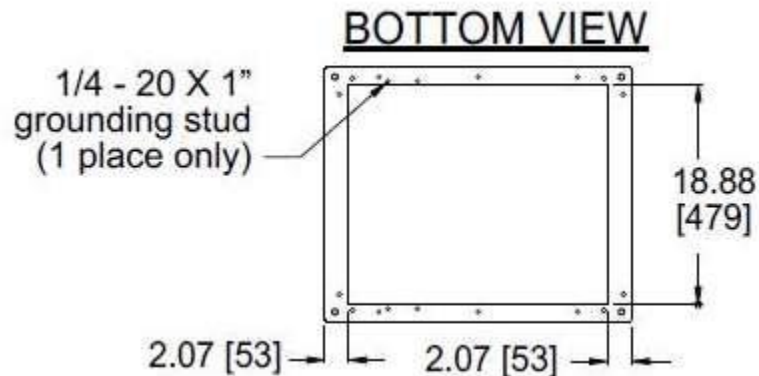

Figure 4-19 – Middle Atlantic 7ft Cabinet Ground Location

### IDF Cabinet

Connect the IPDVS server cabinet to the grounding Busbar with #6 AWG stranded copper conductor routed along the shortest and straightest paths possible, unless otherwise indicated. Avoid obstructing access or placing conductors where they may be subjected to strain, impact, or damage. Connect conductor to the cabinet manufacturer's specified grounding connection point.

**Note:** IDF cabinets have multiple grounding points. Check with the manufacturer's instructions

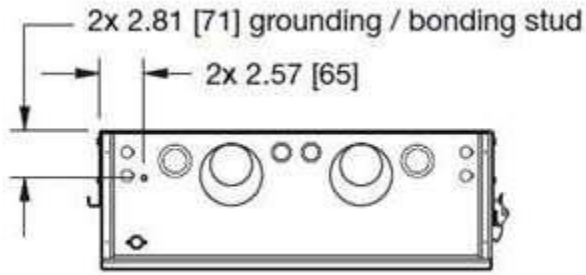

Figure 4-20 – Middle Atlantic IDF Cabinet Ground Location

**Current standard IP Cameras:**

Integrators should be using the AXIS Device Manager to look up and update the latest firmware for all AXIS IP Cameras. If Internet is not available, then a manual download is available through the AXIS website: <https://www.axis.com/support/firmware>

\*\* Note: Never downgrade firmware \*\*

Current Standard IP Cameras	Minimum Firmware (at time of integration)
<b>P3375-LVE – 2.1 MP – Fixed indoor/outdoor dome</b>	<b>9.80.3.1</b>
<b>M3057-PLVE MK II – 6 MP - 180°/360° Indoor/Outdoor</b>	<b>10.4.0</b>
<b>AXIS P3719-PLE – 4 Way 16MP – indoor/outdoor</b>	<b>10.4.0</b>
<b>AXIS P9106-V White – 3MP – corner camera</b>	<b>9.80.3.1</b>
<b>AXIS P5655-E – Indoor Small Form Factor PTZ</b>	<b>10.4.5</b>
<b>AXIS Q6075-E - Outdoor PTZ</b>	<b>10.4.5</b>

**Camera Installation**

Camera Mounting Methodologies

Other than where approval for deviation has been approved by the Designer of Record, IPDVS camera installations are to follow these installation guidelines.

**P3375-LVE – 2.1 MP – Fixed indoor/outdoor dome**

<https://www.axis.com/en-us/products/axis-p3375-lve>

<https://www.axis.com/en-us/products/axis-p3375-lve/software-and-accessories>



<https://www.axis.com/en-us/products/accessory-selector#>

**Installation Guide below:**

[https://www.axis.com/files/manuals/ig\\_p3375lve\\_1808866\\_en\\_1711.pdf](https://www.axis.com/files/manuals/ig_p3375lve_1808866_en_1711.pdf)

		
<p>Eaton type C &amp; LB Conduit (Condulet outlet Bodies) and steel cover with gasket for Commscope modular punch-down jack</p>	<p>Axis P3375-LVE (01063-001)</p>	<p>Recessed Ceiling Mounting Kit is AXIS T94M02L Recessed Mounting Kit (only for Fixed P3375-LVE) (01156-001)</p>
		
<p>Axis T94S01P Conduit Back Box (for fixed cameras) can be used to mitigate minor obstructions. (01190-001)</p>	<p>Commscope UKJ600-ORG Modular punch-down jack</p>	<p>Indoor/Outdoor Wall mount adaptor          AXIS P33-VE 3/4" NPS Conduit Adapter (5503-711 Single) or (5503-721) 4 - piece pack)</p>
		
<p>For fixed cameras: PoE Class 3 always on</p>	<p>AXIS P33-VE Series Pendant Kit (5502-321)</p>	<p>PWM20GB (Beige) / PWM20G (Black) use only for Analog</p>

		
<p>NYDOE 10x8x4 Polycarbonate Enclosure with Solid Door, Latch Lock and Cord Grip (Outdoor Analog use only) ask vendor for installation instructions ATS-1084P-S-L-CG-BBP-CUST1</p>	<p>AXIS T91D61 Wall Mount 1.5" NPS (5504-821)</p>	<p>AXIS T91B63 Fixed Ceiling Mount (5504-641) (add with P33-VE series Pendant Kit) (5502-321) length: 29.5 in</p>
		
<p>AXIS T91B47 Pole Mount (01164-001) use with AXIS T91D61 Wall Mount 1.5" NPS (5504-821)</p>	<p>PACA2 (beige) / (PACA2B black) use for Analog only Use gooseneck arm PWM20GB (Beige) / PWM20G (Black) only for Analog</p>	<p>AXIS T91B50 Telescopic swivel Ceiling Mount Minimum length: (45 in) Maximum length: (84 in) (5507-451)</p>

		
<p>AXIS T91B51 Ceiling Mount (5507-461) (4 in)</p>	<p>AXIS T91A64 Corner Bracket (017-641) use with AXIS T91D61 Wall Mount 1.5" NPS (5504-821)</p>	<p>AXIS T91B52 Extension Pipe 30 cm (12 in) (5507- 491)</p>

**M3057-PLVE MK II – 6 MP - 180°/360° Indoor/Outdoor**

<https://www.axis.com/en-us/products/axis-m3057-plve-mk-ii>

<https://www.axis.com/en-us/products/axis-m3057-plve-mk-ii/software-and-accessories>

<https://www.axis.com/en-us/products/accessory-selector#>

		
<p>AXIS M3057-PLVE MkII (02109-001)</p>		<p>Axis T94S01P Conduit Back Box (for fixed cameras) can be used to mitigate minor obstructions. (01190-001)</p>

**AXIS P3719-PLE – 4 Way 16MP – indoor/outdoor**

		
<p><b>AXIS P3719-PLE (01500-001)</b></p>		<p><b>AXIS T94N01D Pendant Kit (01513-001)</b></p>
		
<p><b>AXIS T94N01L Recessed Mount (01514-001)</b></p>	<p><b>AXIS T91B51 Ceiling Mount (5507-461)</b></p>	<p><b>AXIS T91B50 Telescopic swivel Ceiling Mount (5507-451) Minimum length: (45 in) Maximum length: (84 in)</b></p>
		
<p><b>AXIS T91B52 Extension Pipe 30 cm (12 in) (5507-491)</b></p>	<p><b>AXIS T91D61 Wall Mount 1.5" NPS (5504-821)</b></p>	<p><b>AXIS T91B63 Fixed Ceiling Mount (5504-641) (29 1/2 in)</b></p>

**AXIS P9106-V White – 3MP – Indoor corner camera**

<https://www.axis.com/en-us/products/axis-p91-series/>

<https://www.axis.com/en-us/products/accessory-selector#>



**Indoor Fixed Position – Wall Surface Mount**

1. Install an electrical Eaton conduit outlet body within three inches of the camera location.
2. Connect the Eaton conduit outlet body to the camera back-box ring with conduit.
3. Terminate the Cat6 Permanent Link cable segment inside outlet body with a Commscope UKJ600-ORG RJ45 Modular punch-down jack.
4. Set slide switch on back of camera to "PoE Class 3".
5. Close the Eaton conduit outlet body with a steel conduit body cover and its integral gasket.
6. Verify / install cat 6 cable through sealtite gasket provided.
7. When installing 2 (two) cameras opposite each other in wall hallways, always offset distance 8' feet between them (minimum) and have lenses crisscross.
8. If there are obstructions, (i.e. Exit signs, pipes, beams, clocks) use the backplate on cameras or consider ceiling mount. Drawings may not always depict these obstructions. If there is any confusion, please submit photos to the SCA & DIIT for review and approval.

#### Indoor Fixed Position – Ceiling Surface Mount

1. Install an electrical Eaton conduit outlet body within three inches of the camera location.
2. Connect the Eaton conduit outlet body to the camera back-box ring with conduit.
3. Terminate the Cat6 Permanent Link cable segment inside the outlet body with a Commscope UKJ600-ORG RJ45 Modular punch-down jack. Connect Cat 6 cable to the RJ45 Modular jack and camera before securing camera base to plate.
4. Set slide switch on back of camera to “PoE Class 3”.
5. Close the Eaton conduit outlet body with a steel conduit body cover and its integral gasket..
6. Verify / install cat 6 cable through sealtite gasket provided.
7. When installing 2 (two) cameras opposite each other in ceiling hallways, always offset distance 8’ feet between them (minimum) and have lenses crisscross.
8. If there are obstructions, (i.e. Exit signs, pipes, beams, clocks) use the backplate on cameras or consider wall mount or pipe extensions. Drawings may not always depict these obstructions. If there is any confusion, please submit photos to the SCA & DIIT for review and approval.

#### Indoor Fixed Position – Recessed Ceiling Flush Mount

1. Install an electrical Eaton conduit outlet body in the plenum area near the camera location.
2. Terminate the Cat6 Permanent Link cable segment inside the outlet body with a Commscope UKJ600-ORG RJ45 Modular punchdown jack.
3. Set slide switch on back of camera to “PoE Class 3”.
4. Close the Eaton conduit outlet body with a steel conduit body cover and its integral gasket.
5. Install the recessed flush mount and install the camera within the mount.
6. Verify / install cat 6 cable through sealtite gasket provided.

#### Outdoor Fixed Position – Wall

1. Install the AXIS arm at the location where the camera will be mounted.
2. Terminate the Cat6 Permanent Link cable segment inside the Eaton conduit outlet body near the camera conduit with a Commscope UKJ600-ORG RJ45 Modular punch-down jack.
3. Close the Eaton conduit outlet body with a steel conduit body cover and its integral gasket.
4. Mount the AXIS camera on the AXIS bracket with the pendant mount adaptor.
5. Set slide switch on back of camera to “PoE Class 3”.
6. Verify / install cat 6 cable through sealtite gasket provided.

Outdoor Fixed Position – Corner

1. Install the conduit body outlet to the right or left of the AXIS corner bracket.
2. Terminate the Cat6 Permanent Link cable segment inside the conduit body outlet with a Commscope UKJ600-ORG RJ45 Modular punch-down jack.
3. Mount the AXIS arm to the front of the AXIS corner bracket.
4. Set slide switch on back of camera to “PoE Class 3”.
5. Mount the AXIS camera on the AXIS arm with the pendant mount adaptor.
6. Make a drip loop to end of the conduit outlet body and form a drip loop prior to connection to the AXIS arm.
7. Connect a Cat 6 cable from the camera to the Commscope UKJ600-ORG RJ45 Modular punch-down jack.
8. Close the Eaton conduit outlet body with a steel conduit body cover and its integral gasket.
9. Verify / install cat 6 cable through sealtite gasket provided.

**AXIS P5655-E – Indoor Small Form Factor PTZ**

<https://www.axis.com/en-us/products/axis-p5655-e>

<https://www.axis.com/en-us/products/accessory-selector#>

		
<b>AXIS P5655-E (01682-004)</b>	<b>AXIS T94A01D Pendant Kit (5502-431)</b>	<b>AXIS T94A02L Recessed Mount (5506-171)</b>

**AXIS Q6075-E - Outdoor PTZ**

<https://www.axis.com/en-us/products/axis-q6075-e>

<https://www.axis.com/en-us/products/accessory-selector#>

		
<p><b>AXIS Q6075-E</b> (01752-004)</p>	<p>AXIS T8154 60 W SFP Midspan (included) (5901-004)</p>	<p>AXIS T94A01D Pendant Kit (5502-431)</p>
		
<p>Outdoor IP-66 RJ45 cable, 15 m – (5504-731) Outdoor IP-66 RJ45 cable, 5 m – (5502-731)</p>	<p>Steel face plate with Integral Gasket</p>	<p>AXIS T91D61 Wall Mount 1.5" NPS (5504-821)</p>
		
<p>Eaton type C &amp; LB Conduit (Condulet outlet Bodies) and steel cover with gasket for Commscope modular punch-down jack</p>	<p>Commscope UKJ600-ORG Modular punch-down jack</p>	<p>PWM20GB(Beige)/PWM20G(Black) only for Analog</p>



#### Outdoor PTZ – Wall

1. Install the AXIS arm at the location where the camera will be mounted.
2. Terminate the Cat6 Permanent Link cable segment inside the conduit body outlet with a Commscope UKJ600-ORG RJ45 Modular punch-down jack.
3. Mount the Axis Q6075-E camera to the AXIS arm with the pendant mount adaptor.
  - a) Take extreme care not to cross thread this connection.

4. Connect the Cat6 cable from the camera to the Commscope UKJ600-ORG modular jack.
5. Verify / install cat 6 cable through sealtite gasket provided.



#### Outdoor PTZ – Corner

1. Install the conduit outlet body to the right or left of the AXIS corner bracket.
2. Terminate the Cat6 Permanent Link cable segment inside the conduit outlet body with a Commscope UKJ600-ORG RJ45 Modular punch-down jack.
3. Mount the AXIS arm to the front of the AXIS corner bracket.
4. Mount the Axis Q6075-E camera to the pendant mount adaptor.
  - a) Take extreme care not to cross thread this connection.
5. Connection to be made to the conduit body outlet and form a drip loop prior to connection to the AXIS bracket.
6. Connect the Cat6 cable from the camera to the Commscope UKJ600-ORG modular jack.
7. Verify / install cat 6 cable through sealtite gasket provided.

			
	AXIS T91A64 Corner Bracket / 5017-641	PWM20GB(Beige)/ PWM20G(Black) only for Analog	PACA2 (beige) / (PACA2B black) only for Analog

#### Outdoor PTZ – Parapet

1. Install the conduit body outlet to the right or left of the base of the VG4-A-9230 bracket.
2. Terminate the Cat6 Permanent Link cable segment inside the conduit body outlet with a Commscope UKJ600-ORG RJ45 Modular punch-down jack.
3. Mount the VG4-A-9230 bracket on the parapet.
  - a) Ensure when rotated the camera will be extended fully over the parapet.
  - b) If installing in a corner location, ensure the camera is extended directly outward from the vertex of the corner.
4. Mount the Axis Q6075-E camera on the VG4-A-9230 bracket with the pendant mount adaptor.
  - a) Take extreme care not to cross thread this connection.
5. Connect the Cat6 cable from the camera to the Commscope UKJ600-ORG modular jack.
6. Verify / install cat 6 cable through sealtite gasket provided.

			
	VG4-A-9230	Pendant Mount Adaptor Axis 5502-431	

### Camera Programming

This section describes the camera programming to be performed at time of camera installation. Final PTZ programming to define home position, presets, dwell times, patterns or guard tours may be configured by the SI. Where required, DIIT will complete Final PTZ programming during assessment.

#### Axis Camera Management Software

Axis Client Management Software is the method used to configure Axis cameras when they are first powered on and connected to a network. If they are not connected to a network yet, then a handheld device or laptop can also be used to configure each IP camera. Only values that are not part of the default settings from the factory should be modified. Specific camera settings can be configured through the Axis Management software interface such as setting pre-production credentials, IP addressing, and NTP settings.

**Note:** Production credentials will be assigned by the DIIT IPDVS Deployment team after assessment of the site and meets a minimum of partial acceptance.

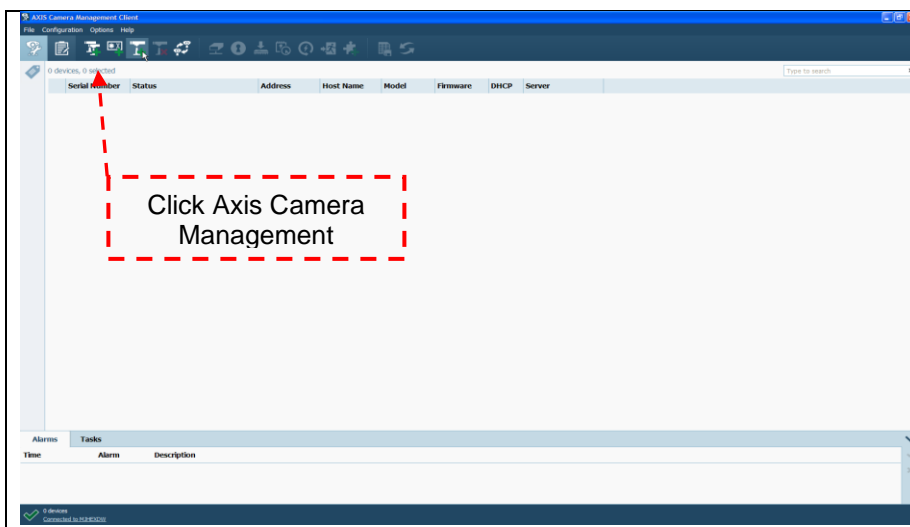

The “Axis camera management software” can be found in the:

**C:\IPDVS Software\Camera Utilities\Axis folder**

- Install software before discovery of cameras

The first time Axis Management software is used it will look like the figure on the left.



- Click the camera management icon to discover all new Axis cameras

Figure 4-21 – Camera setup

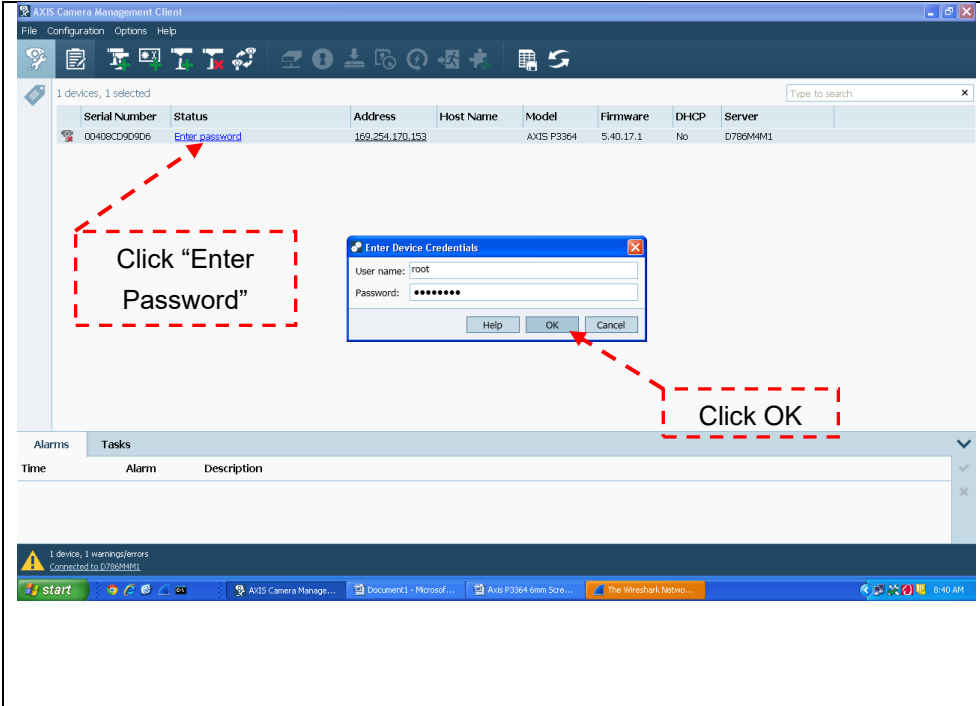

**Select one camera at a time or select all to set User Name and Password.**

- Click “Enter password” and a box will pop up.
- Enter AXIS default username
- Enter AXIS default password
- Click OK

**Note:**  
Default Axis credentials should be specified in the packaged contents that shipped with camera

Figure 4-22 – Camera setup continued

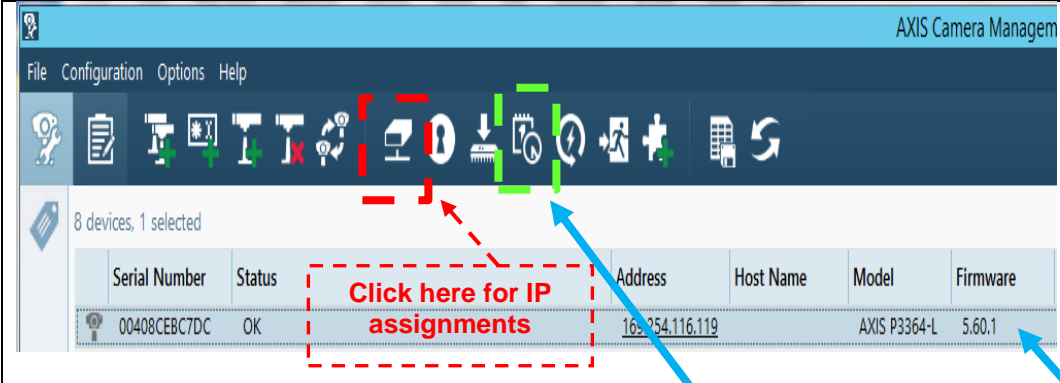

**Note:**  
Remember to highlight all when selecting the all option using “Ctrl-A” on keyboard after highlighting one

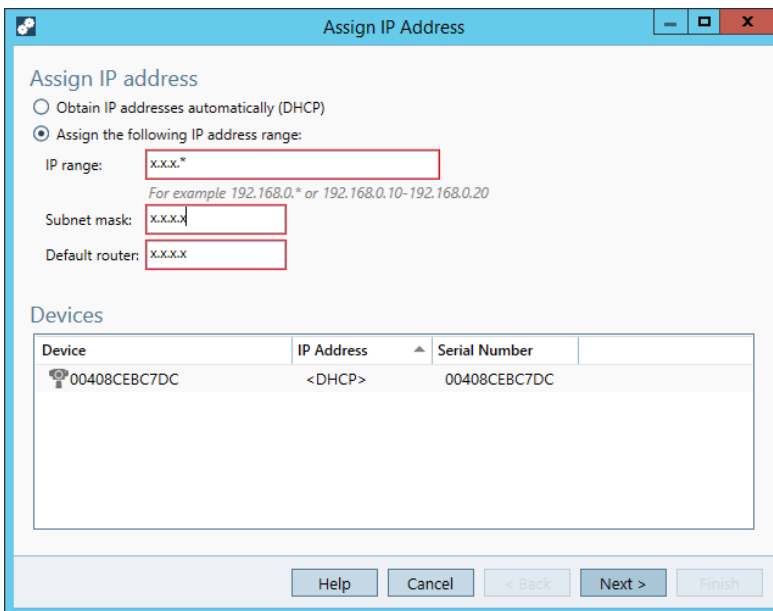
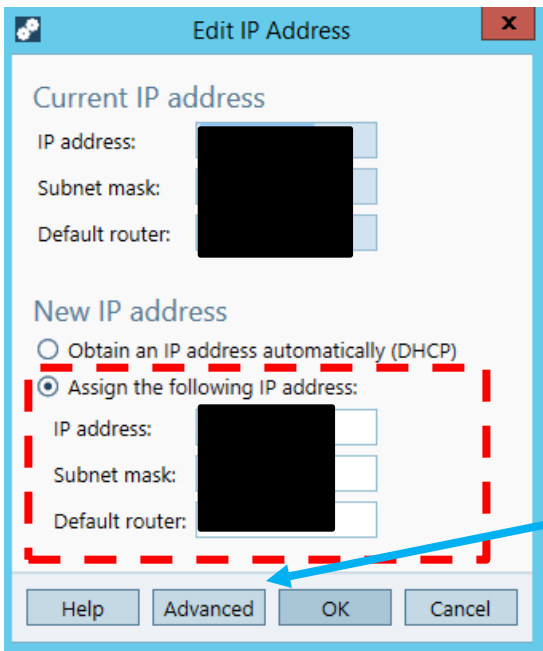

- Step 1a: Select one camera at a time or select all in step 1b
- Step 1b: Or select all and click “Advanced” to assign IP address range for all cameras
- Step 2: Click this icon to assign an NTP Server IP to all cameras only after camera IP assignments have been completed

**Note:**

Please check with the DIIT QA & Engineering support group for the correct NTP Server IP and IP address range to be used for all cameras

Figure 4-23 – Camera setup continued

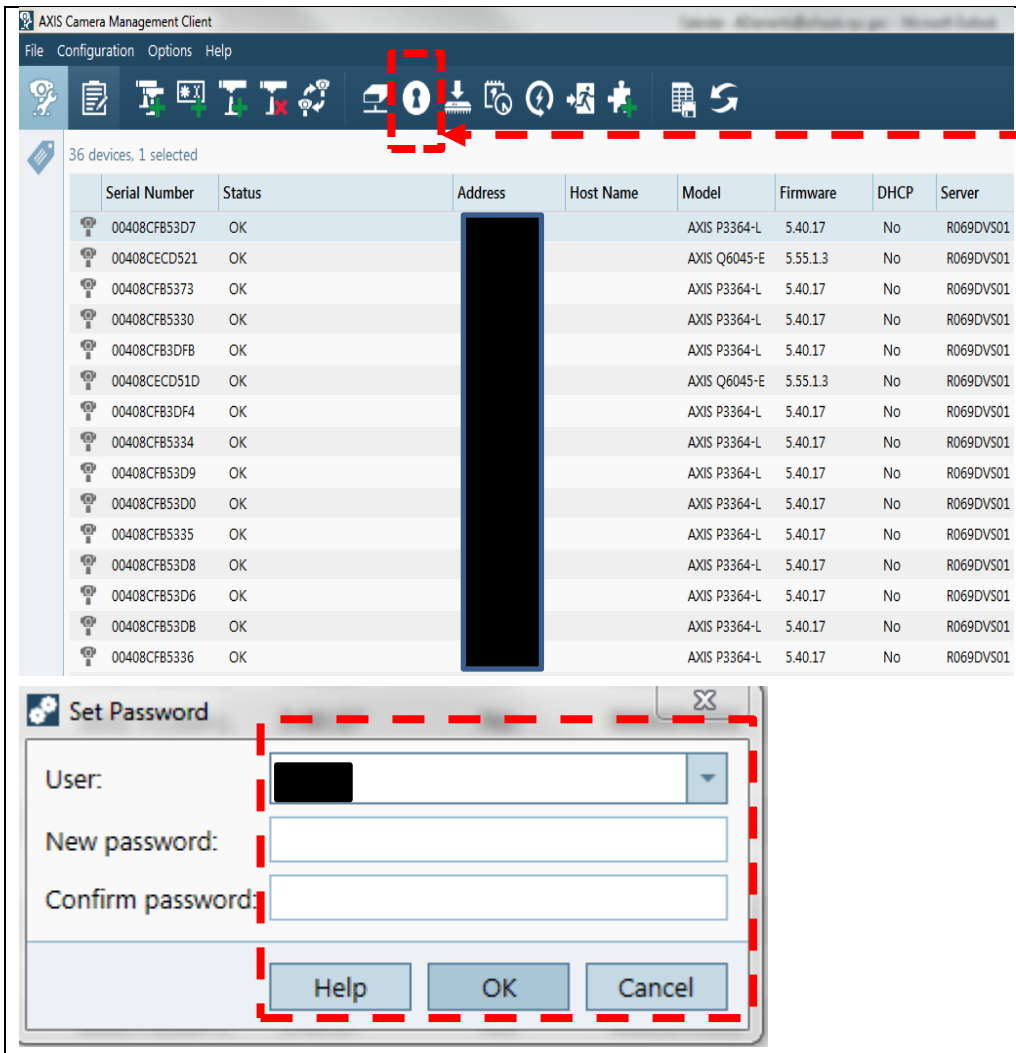

Change password to pre-production on all devices at once by highlighting all devices and clicking on this icon

A dialog box will appear requesting a Password

- Enter pre-production password
- Confirm password
- Click OK

**Note:**

Please check with the DIIT QA & Engineering support and DIIT IPDVS Deployment group for the correct NTP Server IP

Figure 4-24 – Camera setup continued

Axis Web Based Browser Access

Most camera settings will be set using Genetec Security Center Software. Axis cameras come out of the box configured to automatically sense lighting conditions and operate normally. Browser access will be necessary to configure or check a few items that require manual input or troubleshooting issues.

Items that need verification

- Field of View status check (“Live View” is first view after logging in using web browser)
- Check that “NTP” settings were applied from previous step
- Perform “Auto focus” if needed
- Perform “Calibrate Optics” if autofocus is not working properly

<p>Your connection to this site is not private</p> <p>Username <input type="text" value="root"/></p> <p>Password <input type="password" value="*****"/></p> <p><input type="button" value="Sign in"/> <input type="button" value="Cancel"/></p>	<p>Enter credentials for this camera:</p> <ul style="list-style-type: none"> <li>• Enter pre-production User name</li> <li>• Enter pre-production Password</li> <li>• Click OK</li> </ul> <p><b>Note:</b></p> <p>On occasion, if a camera is reset or factory defaulted, the following might happen while logging into a camera for the first time through the web browser. The user might be asked whether to use “50 Hz” or “60 Hz”. Always use “60 Hz” which is the standard Electrical power frequency in the US. <b>Never use 50 Hz.</b></p>
-------------------------------------------------------------------------------------------------------------------------------------------------------------------------------------------------------------------------------------------------	---------------------------------------------------------------------------------------------------------------------------------------------------------------------------------------------------------------------------------------------------------------------------------------------------------------------------------------------------------------------------------------------------------------------------------------------------------------------------------------------------------------------------------------------------

Figure 4-25 – Camera setup continued

	<p>The browser may show a message indicating that “This website wants to run the following add-on: “Axis Media Control from Axis Communications...” If you trust the website and the add-on and want to allow it to run, click here.</p> <ul style="list-style-type: none"> <li>• Right click the yellow area</li> </ul>
--------------------------------------------------------------------------------------	--------------------------------------------------------------------------------------------------------------------------------------------------------------------------------------------------------------------------------------------------------------------------------------------------------------------------

Figure 4-26 – Camera setup continued



The yellow area will change to blue and it will give you a several choices.

- Select Run Add-on

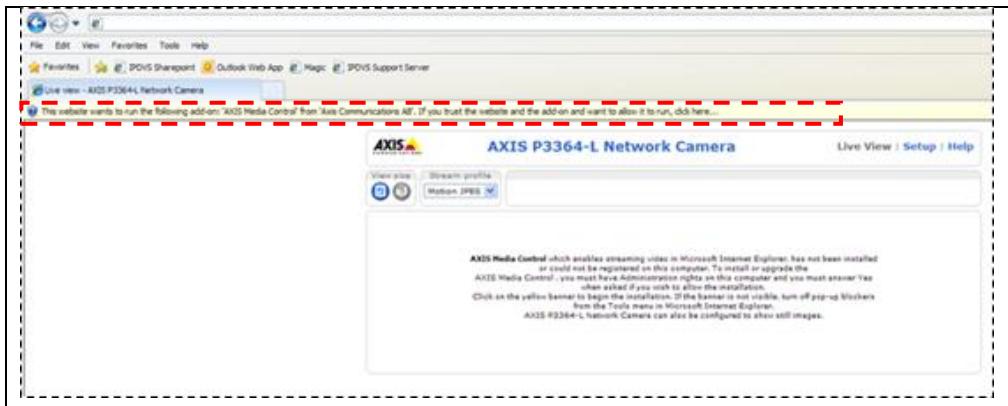
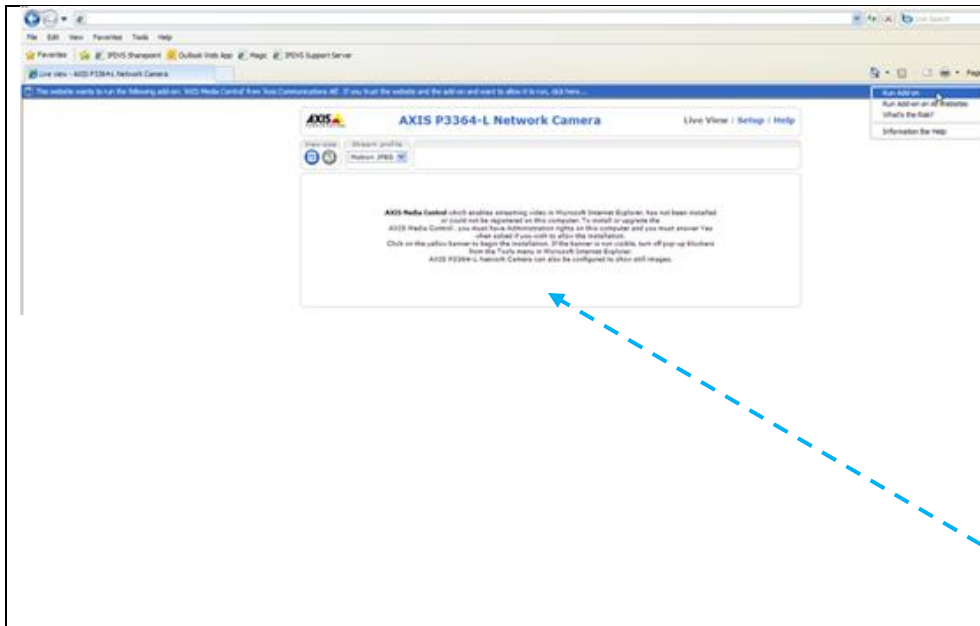
**Note:**

If add-on does not run you can manually install it from:

**C:\IPDVS Software\Camera Utilities\Axis Media Controller\AMC\_Embedded\_msi.msi**

- After successful installation, live video should be viewed in this view

Figure 4-27 – Camera setup continued

**AXIS Basic Setup – Check “Date & Time Settings” menu**

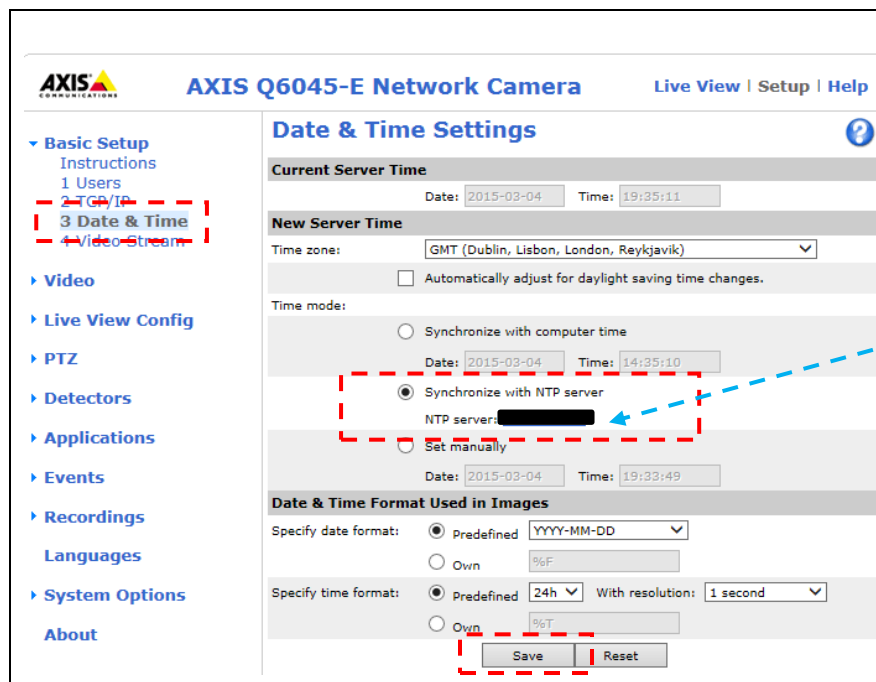

- In the Date & Time Basic Setting set “Time mode” to “Synchronize with NTP server”
- IP should be populated if it was entered in the AXIS Camera Management phase of the camera setup. If not, then click and enter the NTP server IP
- Use the default settings for all other settings. (See image at the left)
- Always click Save if a change is made

Figure 4-28 – Camera setup continued

**Note:** The Axis Q6045-E PTZ camera does not need auto focus adjustments; by default it auto focuses.  
**Axis Basic Setup – Check Focus & Zoom menu, Advance Tab menu**

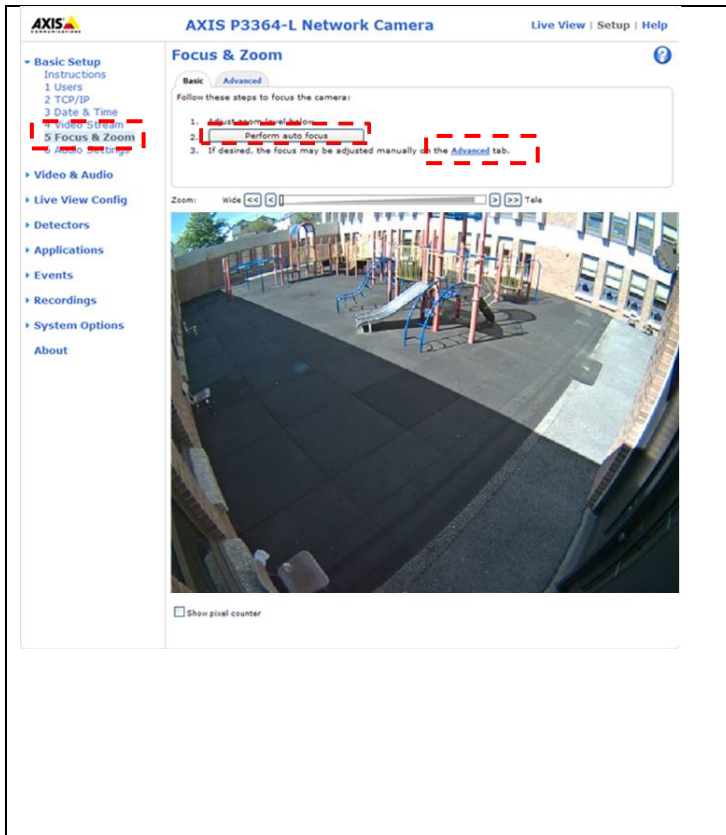

Figure 4-29 – Camera setup continued

The Focus & Zoom settings menu allows the operator to focus the camera manually or by using the auto focus button.

To focus the camera do the following:

- Make sure the camera has the proper field of view
- Press Perform auto focus button (see picture at the left) to begin the auto focus function
- If needed, click “Advanced” to adjust and tweak the Zoom in or Zoom out

To manually focus camera far or near:

- Adjust the focus slider button to the left to adjust Near or slider button to the right to adjust Far

To manually zoom wide or tele:

- Adjust the Zoom slider button to the left, to “Zoom Wide”
- Adjust the Zoom slider button to the right, to “Zoom Tele”

### Axis Basic Setup – Check Calibrate Optics

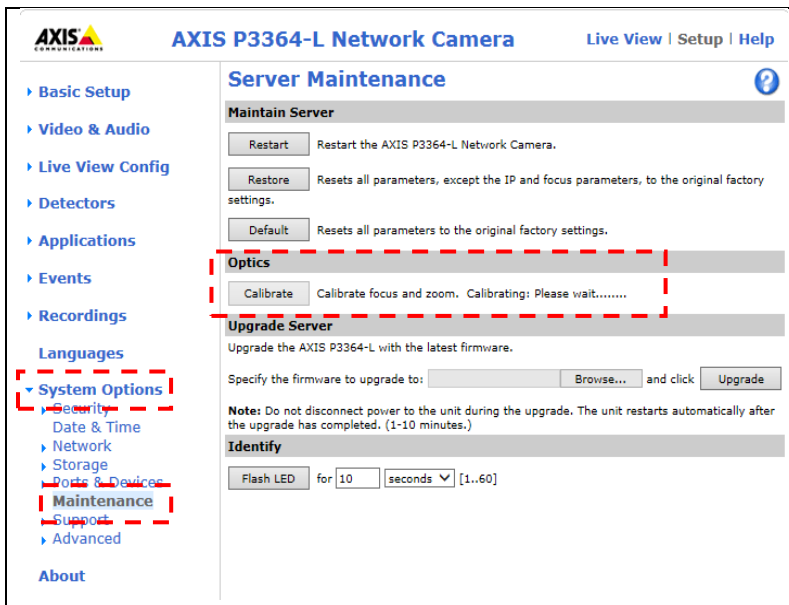

Figure 4-30 – Camera setup continued

The Calibrate Optics function should be performed only if an auto focus fails

To Calibrate the Optics of the camera:

- Click on “System Options”
- Click on “Maintenance”
- Under “Optics”, click on “Calibrate”
- Once calibration is finished, perform an auto focus procedure again
- If the camera is still out of focus, it may be defective and will need to be replaced

Items that require manual input

- Host names for each camera have to be input (format is “**Rack code – Camera ID**”, (see example below)
  - a) For example at school R069: **31R069-E1-10** (no spaces), see Figure 31
  - b) Disabling “Audio functionality”

### Axis advanced Setup – Host Name Configuration

**AXIS P3364-L Network Camera** Live View | Setup | Help

**Advanced TCP/IP Settings**

**DNS Configuration**

Obtain DNS server address via DHCP

Use the following DNS server address:

Domain name:  (use ; to separate names)

Primary DNS server:

Secondary DNS server:

**NTP Configuration**

Obtain NTP server address via DHCP

Use the following NTP server address:

Network address:  (host name or IP address)

**Host Name Configuration**

Use the host name:

Enable dynamic DNS updates

Register DNS name:  (Axisproduct.example.com)

TTL:

**Link-Local IPv4 Address**

Auto-Configure Link-Local Address

**HTTP**

HTTP port:

**HTTPS**

HTTPS port:

**NAT traversal (port mapping) for IPv4**

NAT traversal is disabled.

Use manually selected NAT router:  (LAN IP address)

Alternative HTTP port:  \*

\* If set to blank or 0, a port number will be set automatically upon enable.

**FTP**

Enable FTP server

**RTSP**

Enable RTSP server\*

RTSP port:

\* H.264 video streams will be unavailable if this is disabled.

To manually enter a Host Name:

- Click on “System Options”
- Click on “Network”
- Click on “Advanced”
- Under “Host Name Configuration”
- Enter “Rack code – Camera id”
- Click “Save” at the bottom of the page

Figure 4-31 – Camera setup continued

**Note:** The Axis Q6055-E PTZ camera does not use audio

## Axis Basic Setup – Audio Settings menu

		<p>This section allows for Audio adjustments.</p> <p>Audio should always be disabled.</p> <p>Set the following:</p> <ul style="list-style-type: none"> <li>• Input gain: “Mute”</li> <li>• Output gain: “Mute”</li> <li>• Click “Save”</li> </ul> <p>Make certain the input gain is on mute. Check for lack of red, yellow, or green colors in the level window.</p>
--	--	----------------------------------------------------------------------------------------------------------------------------------------------------------------------------------------------------------------------------------------------------------------------------------------------------------------------------------------------------------------------

Figure 4-32 – Camera setup continued

## Axis System Options – Audio Support menu

		<p>The audio support menu allows the operator to enable or disable audio.</p> <ul style="list-style-type: none"> <li>• Un-check “Enable audio support”</li> <li>• Click “Save”</li> </ul>
--	--	-------------------------------------------------------------------------------------------------------------------------------------------------------------------------------------------

Figure 4-33 – Camera setup continued

## Camera Labeling

All camera bodies are to be labeled with two pieces of information:

1. The room number of the telecommunications closet where the drop terminates, a dash, and
2. The IPDVS camera number

The recommended label format is:

- Label type: Avery 5667 – Return Address Label [.5”H x 1.75”W] or equivalent
- Label font: Arial 20 pt. or equivalent

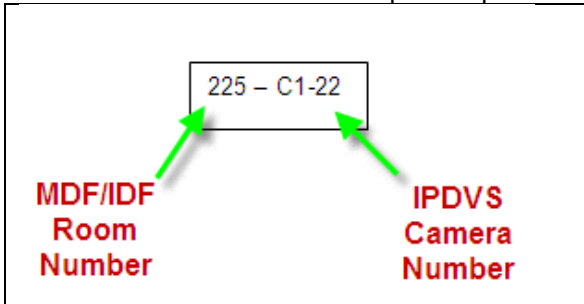

Figure 4-34 - Sample of a Camera Body Label: Camera Number C1-22 whose cable terminates in Room# 225

## Systems Integration

### Physical Installation / Connections

#### Server Rack and Stack

Rack the server and IPDVS equipment as follows

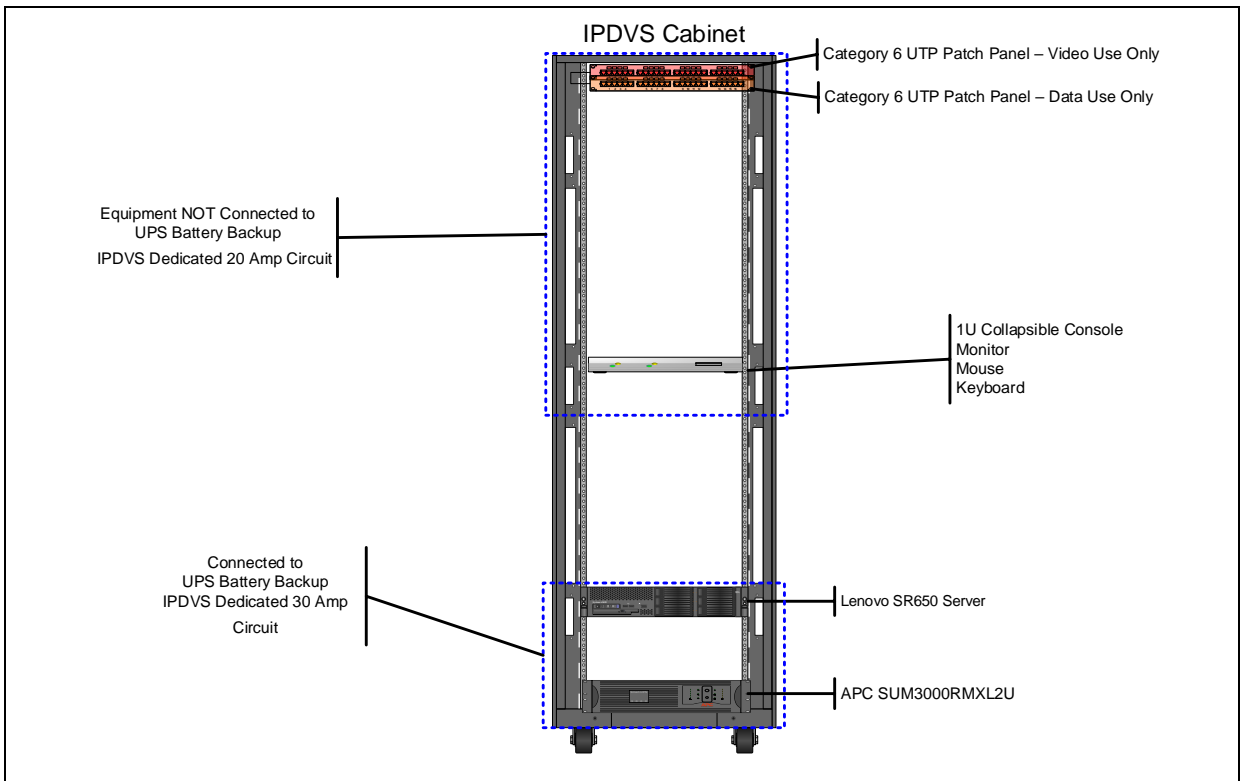

Figure 4-35 - IPDVS Server Cabinet Elevation

Install the IPDVS equipment at the specified RU elevations. Other than the top and bottom RU spaces, the numbers are the recommended placement. Adjustments allowed for field conditions. Leave no empty RU spaces between the patch panels, and switch(s).

<b>Rack Unit (RU) Space</b>	<b>Device</b>
RU 42 (Top) .....	Cat-6 Data Patch Panel
RU 41 .....	Cat-6 Video Patch Panel
RU 40 to 32 .....	Switch or additional fiber terminated equipment
RU 25 .....	Belkin Console
RU 14 and 13 .....	Lenovo Server
RU 3 and 2 (Bottom) .....	APC UPS

Server Connections

Connect the IBM Server as follows.

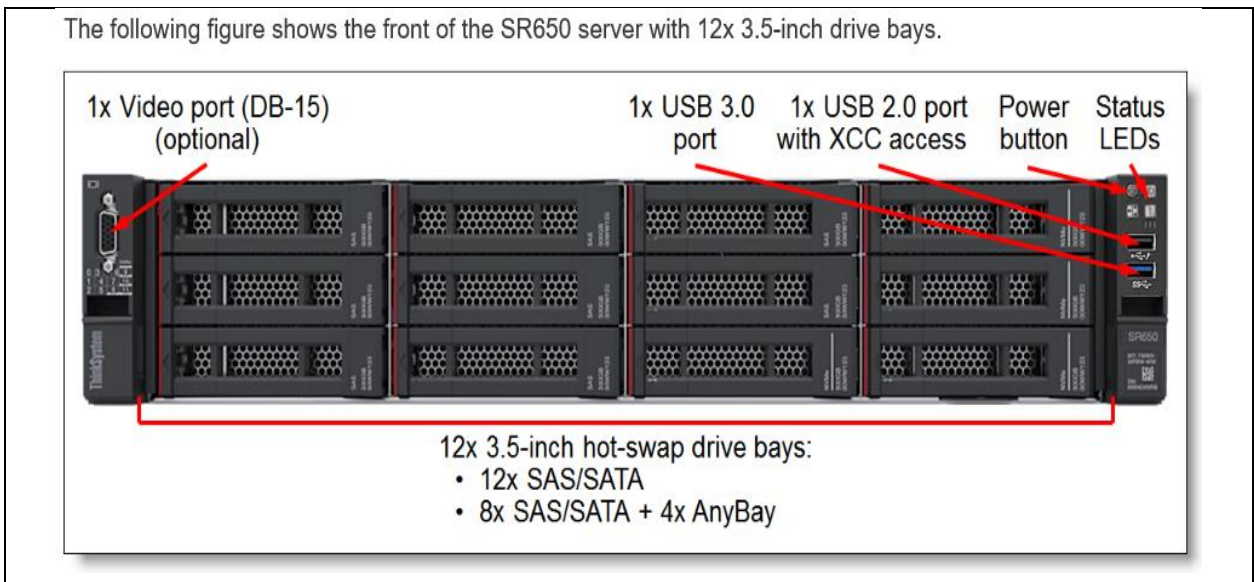

The following figure shows the rear of the SR650 server.

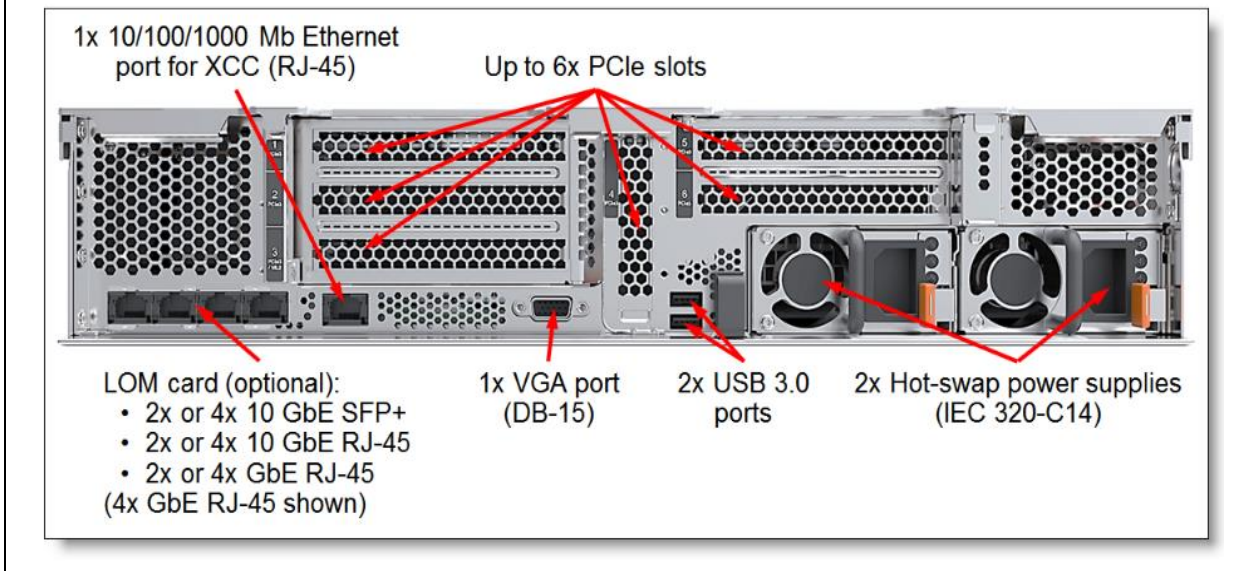

Figure 4-36 - Lenovo SR650 Server Wireframe Drawing

#### Electrical Power

The power from each server should be plugged into one of the following groups as listed below:

- Server 1 – Power Supply 1 – Group 1
- Server 1 – Power Supply 2 – Group 2
- Server 2 – Power Supply 1 – Group 1 (If Applicable)
- Server 2 – Power Supply 2 – Group 2 (If Applicable)

Group 3 should be disabled as we will not be using it. This is a single twist lock receptacle.

#### Ethernet Connections

Connect the system management Ethernet port to the IMM port specified in the submitted design.

Connect ethernet-1 to the IPDVS server port specified in the submitted design.

Do not connect Ethernet-2.

#### Video Console Connection

Connect the DB15 video connector to the console monitor.

## UPS Connections

Connect the APC UPS as follows.

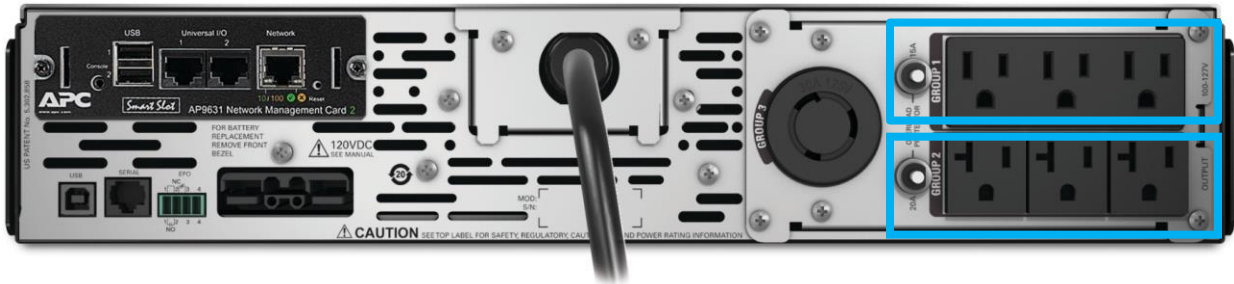

Figure 4-37 - UPS Connections

### Electrical Power

The UPS shall be connected to the IPDVS dedicated 30 amp circuit

### Ethernet Connection

Connect the UPS Ethernet port to the Cisco switch port specified on the submitted design

### UPS Outlet Connections

Connect server devices to the UPS outlets as specified.

The power from each server should be plugged into one of the following groups as listed below:

- Server 1 – Power Supply 1 – Group 1
- Server 1 – Power Supply 2 – Group 2
- Server 2 – Power Supply 1 – Group 1 (If Applicable)
- Server 2 – Power Supply 2 – Group 2 (If Applicable)

Group 3 should be disabled as we will not be using it. This is a single twist lock receptacle.

## Server Specifications

This section provides technical information about the IPDVS Server.

Server Machine Type Model (MTM) .....	LENOVO SR650 (7X06)
Server Product ID (PID).....	7X06
Installed Memory .....	128 GB
Storage Controller.....	ThinkSystem RAID 930-16i 4GB Flash PCIe
Storage .....	Qty. 12 4TB SAS drives (Plus 2 1TB SAS drives for OS)
Operating System .....	Windows Server 2016 Datacenter (64-bit)
Database .....	SQL Server 2016



5. Disable IPv6 in the NIC properties window

Disable any unassigned NICs.

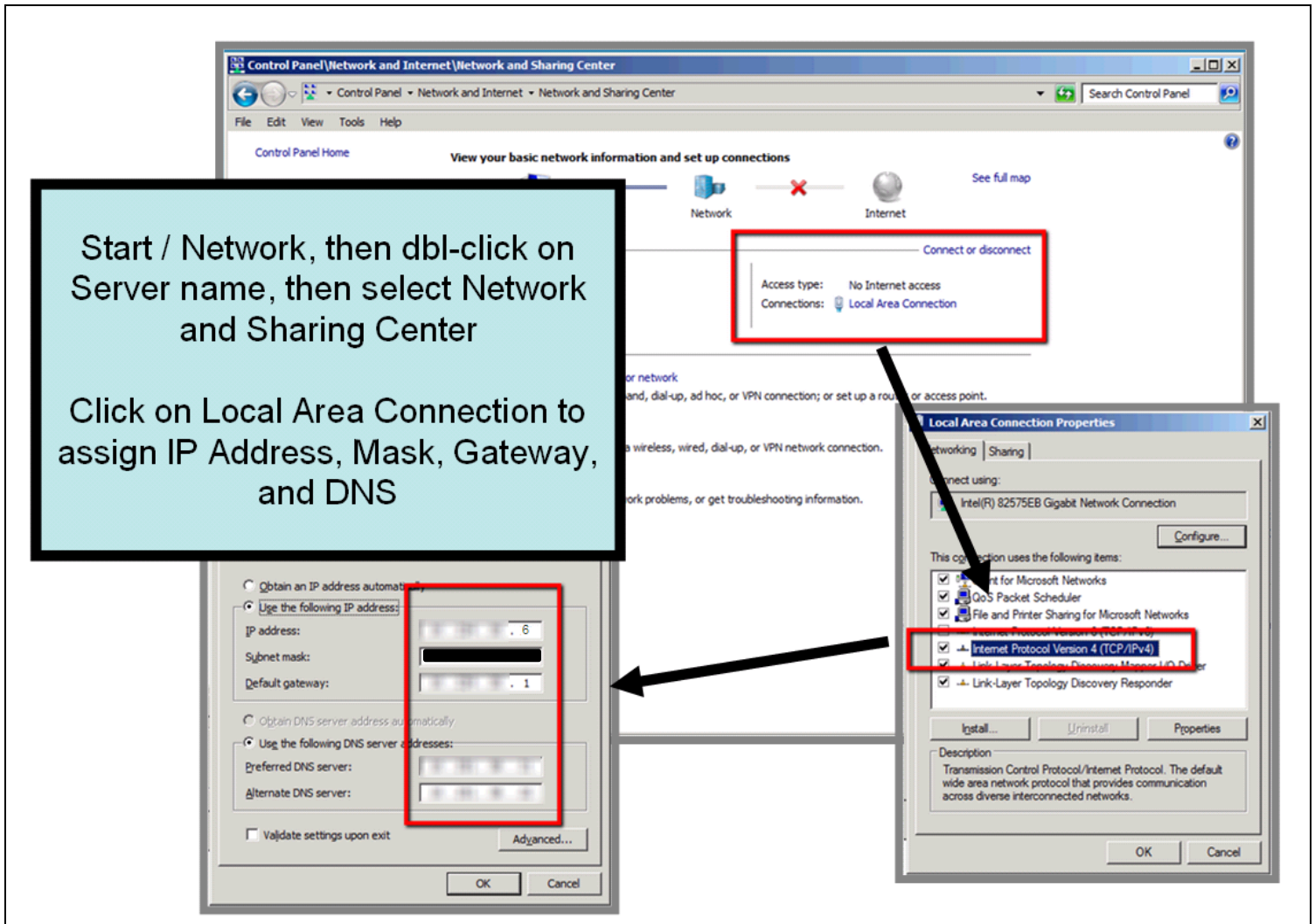

Figure 4-39 - IP Configuration

### Change System Properties

Change the following System Properties

1. Change computer name
  - a. The computer name is the **Building ID** followed by **DVS01**.
    - i. An example of **Building ID K000** would be **K000DVS01**.
    - ii. An example of a second expansion server would be **K000DVS02**.
    - iii. Do not use school's ID or rack's ID for this name, the name must be based on the Building ID.
    - iv. The full computer name field will automatically populate after being set – **do not modify**.
2. Change computer description

- a. Enter **IPDVS SERVER SR650**.
3. The workgroup will be WORKGROUP by default – **do not modify**.

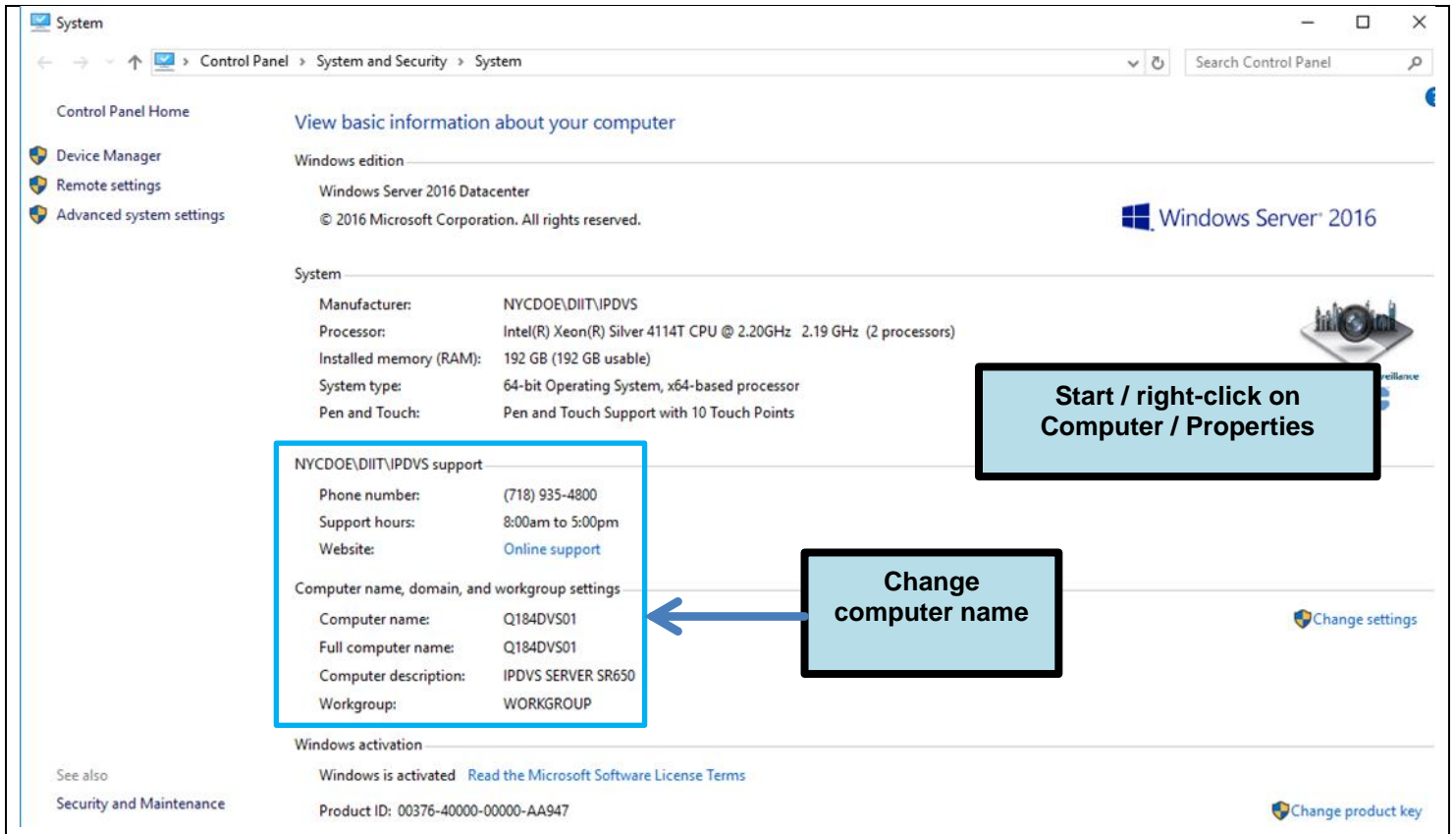

Figure 4-40 - Computer Name Configuration

#### Activate Windows Server – Windows Server 2016 Datacenter Version

Integrators will no longer purchase server OS licensing. Licensing will occur through the KMS (Key Management Service) method. The Key Management Server providing this service is managed by DIIT. The KMS instructions will be provided to integrators by DIIT QA & Engineering Support group. **Network IP configuration must be completed before KMS services are accessible.**

#### LSA replaces MegaRAID

Shortcut is on Desktop to verify Drives (RAID-1 for OS and SQL, RAID-6 w/ 2 Dedicated spare drives for Archive Retention)

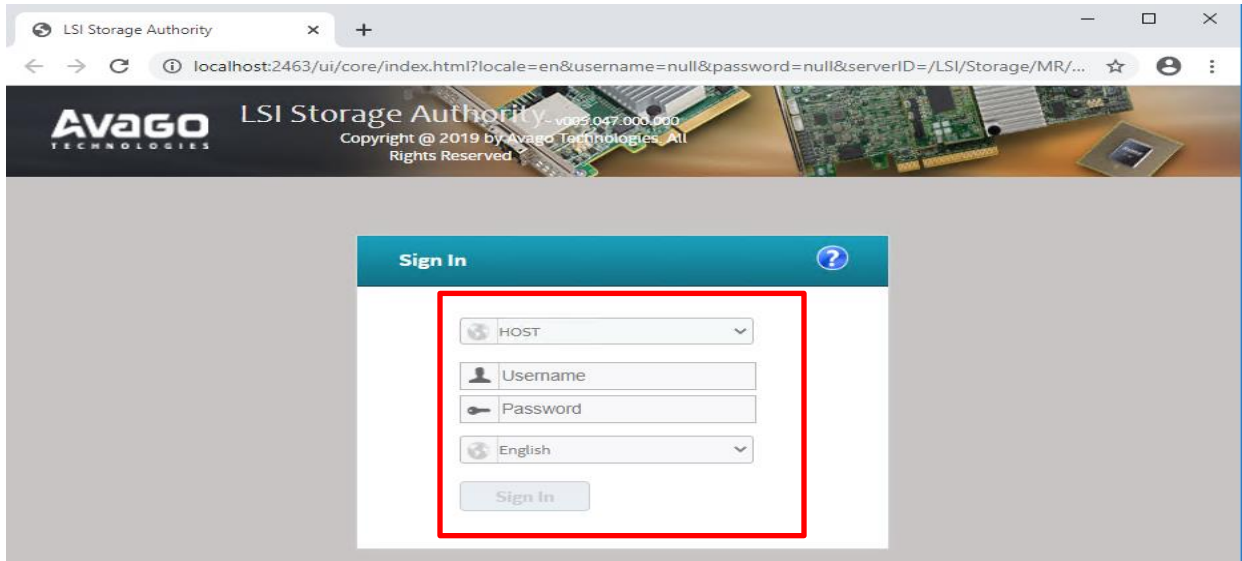

Figure 4-41 – MegaRAID Configuration

#### Verifying RAID-6 Virtual Drive for Archiving and Disk Management Configuration

LSA is only used for verifying what was configured through the LENOVO X-Clarity setup during staging of RAID-6 Configuration. Drives already configured for Archiving. Integrator verifies prior to Security Center Install.

1. Launch LSA Storage Manager
  - a) Use windows credentials
2. Choose Controller
3. Check that settings are optimal and no other errors

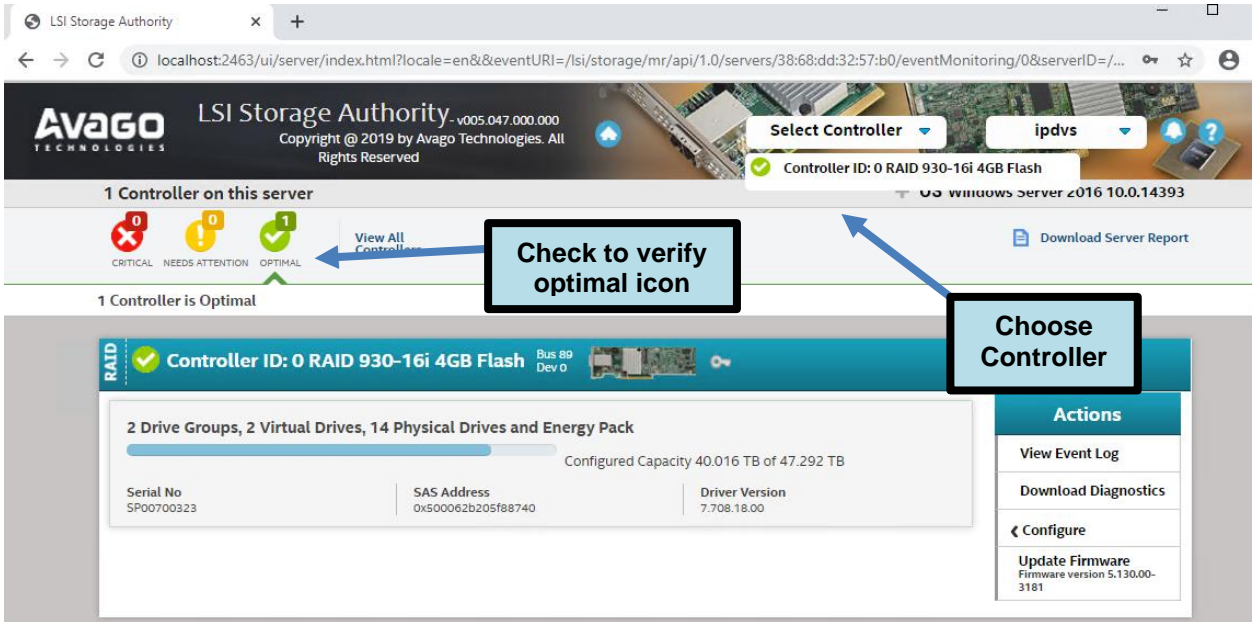

Figure 4-42 – RAID Configuration

- Expand all Physical drives within Drive group 0 and Drive group 1

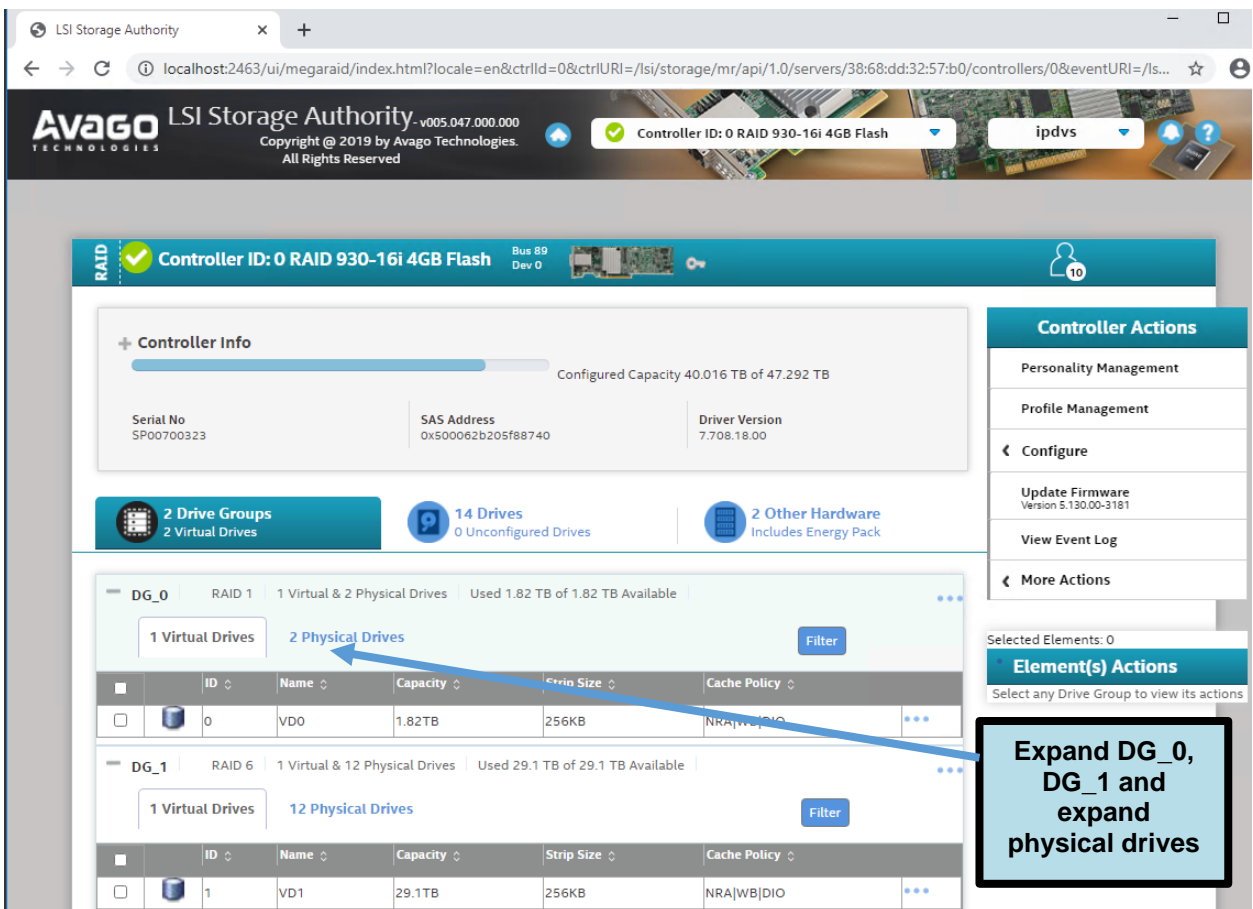

Figure 4-43 – RAID Configuration

Verifying RAID-6 Virtual Drive for Archiving and Disk Management Configuration

LSA RAID is only used for verifying what was configured through the LENOVO X-Clarity BIOS RAID-6 Configuration during staging.

- If the drives are not setup as depicted below, do not setup Genetec Security Center and contact staging vendor for guidance.

The screenshot displays the RAID configuration interface. At the top, it shows '2 Drive Groups' (2 Virtual Drives), '14 Drives' (0 Unconfigured Drives), and '2 Other Hardware' (Includes Energy Pack). The main area shows two drive groups:

- DG\_0 (RAID 1):** 1 Virtual & 2 Physical Drives. Used 1.82 TB of 1.82 TB Available. It contains 1 Virtual Drive and 2 Physical Drives (EN\_134:0 and EN\_134:1).
- DG\_1 (RAID 6):** 1 Virtual & 12 Physical Drives. Used 29.1 TB of 29.1 TB Available. It contains 1 Virtual Drive and 12 Physical Drives (EN\_134:2 through EN\_134:11, plus two hot spares EN\_134:24 and EN\_134:25).

Callouts provide additional information:

- Physical Drives 0 and 1 (Slot 0 and Slot 1) will always be the RAID-1 array for the C:\Drive. (VD0 refers to Virtual Drive 0)
- All remaining drives will be added to a single RAID-6 Drive Group (VD1 refers to Virtual Drive 1)
- New 2 Dedicated Hot Spare Drives (Dedicated only to VD1)

EnclosureSlot	Device ID	Type	Interface	Capacity	Sector Size	Model
EN_134:0	0	HDD	SAS			
EN_134:1	1	HDD	SAS			
EN_134:2	6	HDD	SAS	3.64TB	512B	MG045CA40EN
EN_134:3	2	HDD	SAS	3.64TB	512B	MG045CA40EN
EN_134:4	9	HDD	SAS	3.64TB	512B	MG045CA40EN
EN_134:5	5	HDD	SAS	3.64TB	512B	MG045CA40EN
EN_134:6	8	HDD	SAS	3.64TB	512B	MG045CA40EN
EN_134:7	7	HDD	SAS	3.64TB	512B	MG045CA40EN
EN_134:8	4	HDD	SAS	3.64TB	512B	MG045CA40EN
EN_134:9	12	HDD	SAS	3.64TB	512B	MG045CA40EN
EN_134:10	13	HDD	SAS	3.64TB	512B	MG045CA40EN
EN_134:11	3	HDD	SAS	3.64TB	512B	MG045CA40EN
EN_134:24(Hot Spare)	10	HDD	SAS	3.64TB	512B	MG045CA40EN
EN_134:25(Hot Spare)	11	HDD	SAS	3.64TB	512B	MG045CA40EN

Figure 4-44 – RAID Configuration Continued

- The resulting Drive Group (DG) and VDs should appear as indicated in **figure** above.
- If this view is not there, then the server has not been setup correctly by the staging services vendor.
- Physical drive assignments should match table below.
- Proceed to Windows disk management below.

<b>SERVER SLOT</b>	<b>DRIVE #</b>	<b>SIZE</b>	<b>RAID CONFIGURATION</b>	<b>VIRTUAL DRIVE (VD) ASSIGNMENT</b>
0	0	1 TB	RAID 1	VD 0
1	1	1 TB	RAID 1	VD 0
2	2	4 TB	RAID 6	VD 1
3	3	4 TB	RAID 6	VD 1
4	4	4 TB	RAID 6	VD 1
5	5	4 TB	RAID 6	VD 1
6	6	4 TB	RAID 6	VD 1
7	7	4 TB	RAID 6	VD 1
8	8	4 TB	RAID 6	VD 1
9	9	4 TB	RAID 6	VD 1
10	10	4 TB	RAID 6	VD 1
11	11	4 TB	RAID 6	VD 1
12	12	4 TB	DEDICATED HOTSPARE	VD 1
13	13	4 TB	DEDICATED HOTSPARE	VD 1

Figure 4-45 – MegaRAID Configuration Continued

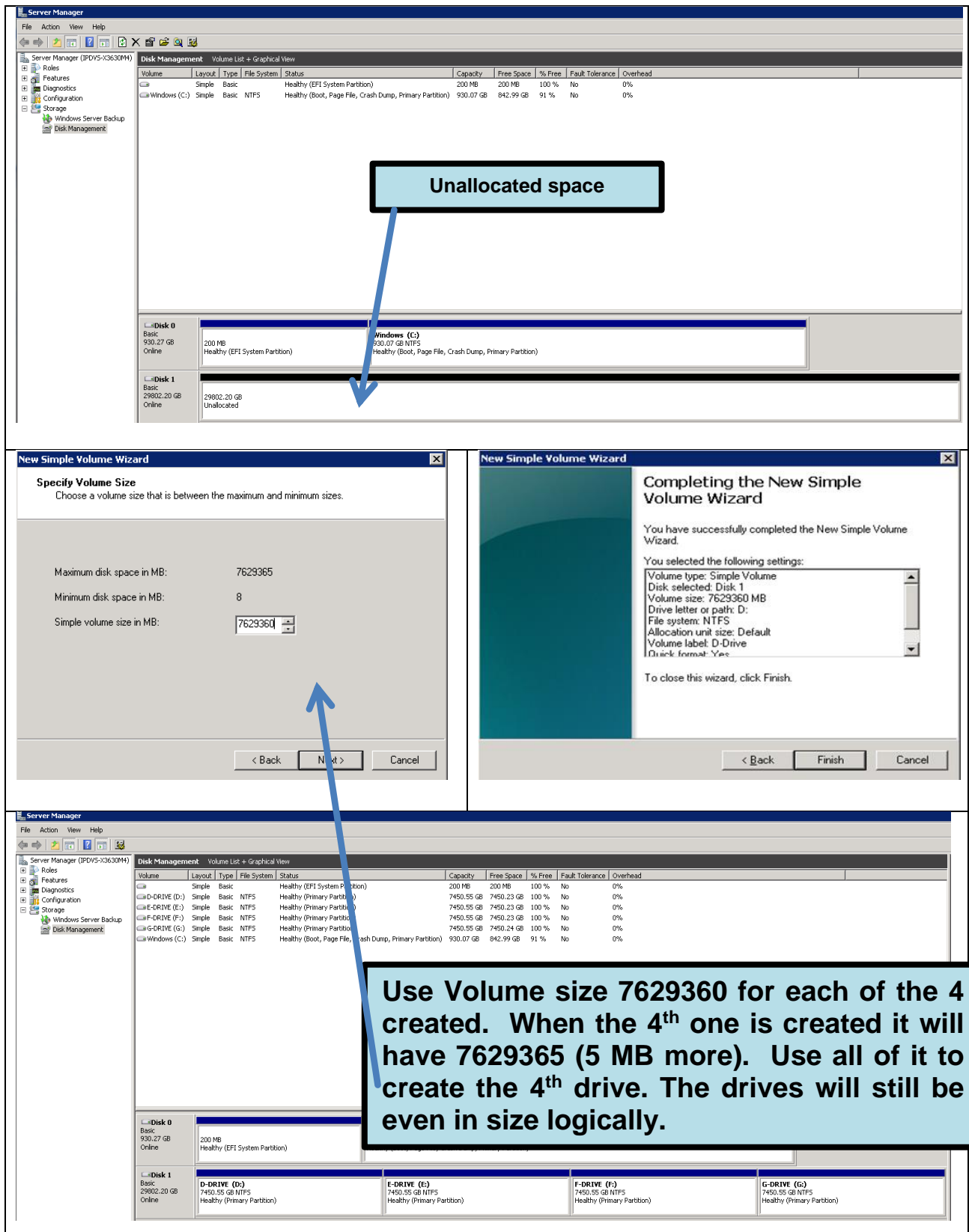

Figure 4-46 – Disk Management Configuration

1. Open Server Manager and select Disk Management and for each disk:
  - a. Create a New Simple Volume
  - b. Name the volume according to its drive letter (e.g. D-DRIVE for the D: drive, E-DRIVE for the E: drive)
  - c. Initialize and format each drive

The screenshot shows the Disk Management console in Windows Server Manager. The top table lists the following volumes:

Volume	Layout	Type	File System	Status	Capacity	Free Space	% Free	Fault Tolerance	Overhead
Windows (C:)	Simple	Basic	NTFS	Healthy (Primary Partition)	930.07 GB	845.40 GB	91 %	No	0%
D-Drive (D:)	Simple	Basic	NTFS	Healthy (Primary Partition)	7450.55 GB	7450.23 GB	100 %	No	0%
E-Drive (E:)	Simple	Basic	NTFS	Healthy (Primary Partition)	7450.55 GB	7450.23 GB	100 %	No	0%
F-Drive (F:)	Simple	Basic	NTFS	Healthy (Primary Partition)	7450.55 GB	7450.23 GB	100 %	No	0%
G-Drive (G:)	Simple	Basic	NTFS	Healthy (Primary Partition)	7450.55 GB	7450.24 GB	100 %	No	0%

Below the table, the graphical view shows Disk 0 with a 200 MB EFI System Partition and a 930.07 GB NTFS partition (C:). Disk 1 is divided into four 7450.55 GB NTFS partitions labeled D:, E:, F:, and G:.

**Unused Space, do not change this if present**

**Open Server Manager and use Disk Management to Initialize and format all newly created Drives. When you right-click on the partitions, you will select "New Simple Volume"**

**Please name the drives as you format them according to their drive letter. For example, D-DRIVE, E-DRIVE, etc.**

**\*\*\*\* NOTE – there is no internal CD/DVD Rom Drive**

Figure 4-47 – Disk Management Configuration Continued

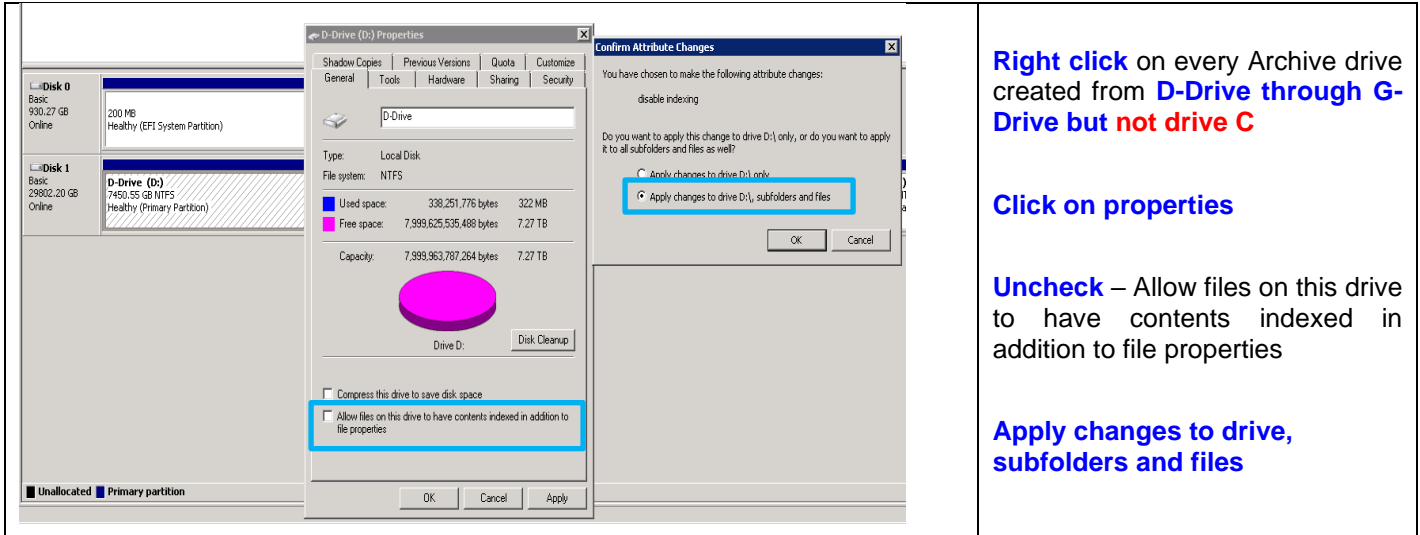

Figure 4-48 – Disk Management Configuration Continued

**APC UPS HARDWARE PRE-INSTALLATION**



Figure 4-49 – APC UPS Intall

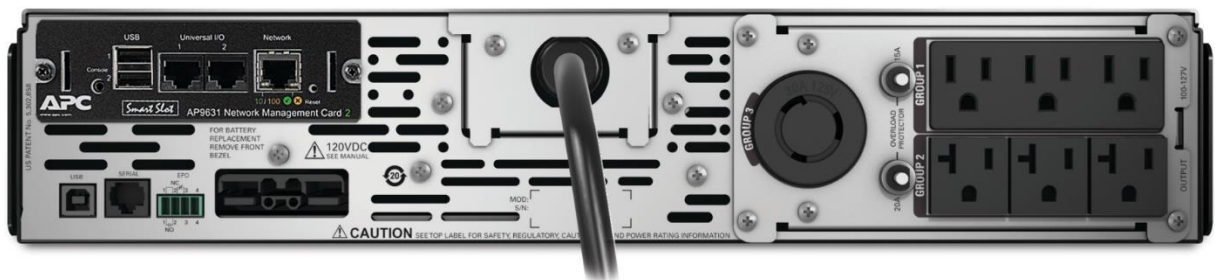

Figure 4-50 - MegaRAID Configuration Continued

- The power from each server should be plugged into one of the following groups as listed below:
  - Server 1 – Power Supply 1 – Group 1
  - Server 1 – Power Supply 2 – Group 2
  - Server 2 – Power Supply 1 – Group 1 (If Applicable)
  - Server 2 – Power Supply 2 – Group 2 (If Applicable)
- Group 3 should be disabled as we will not be using it. This is a single twist lock receptacle.

### SETTING UP AND CONFIGURING UPS

1. After assigning the UPS, its Network Management Card (NMC) IP address, login to the UPS via a web browser using the newly assigned IP address.
2. Go to Configuration -> Outlet Groups. Ensure outlet-groups 1 and 2 are on.
3. Disable the Group 3 outlet.
  - a. Control -> Outlet Groups -> Outlet Group 3 -> Off Immediately -> Next -> Apply
  - b. Confirm that the state of Group 3 is off.

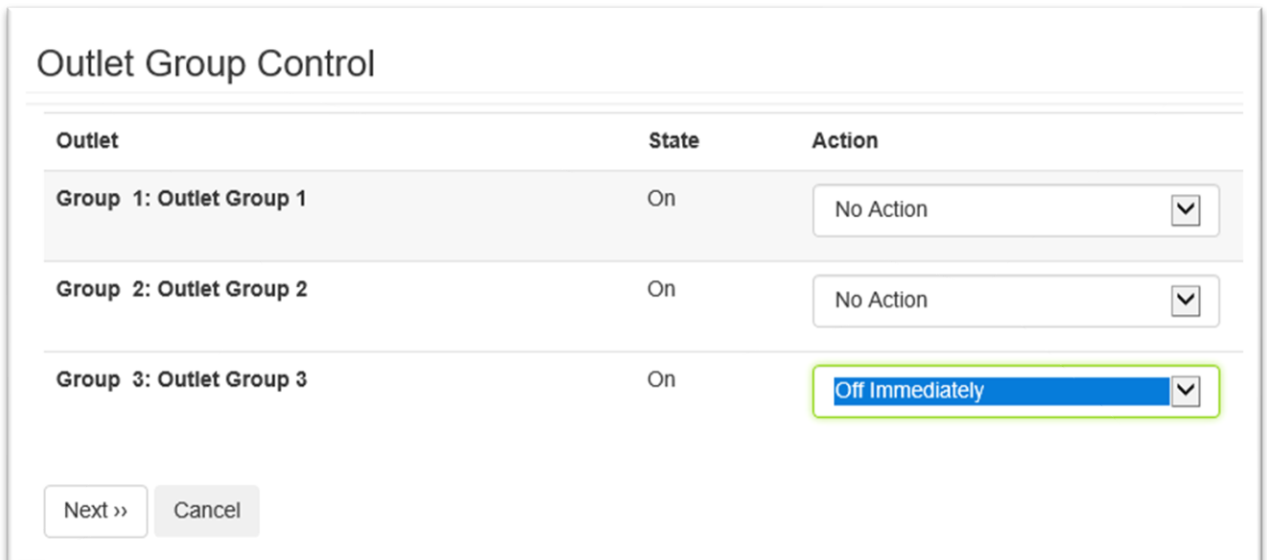

Figure 4-51 – APC Web Interface

## Outlet Group Control Confirmation

Group 1: Outlet Group 1  
No Action

Group 2: Outlet Group 2  
No Action

Group 3: Outlet Group 3  
The Outlet Group will turn off immediately. The Outlet Group will remain off.

Figure

4-52 – APC Web Interface

## Power Settings Configuration

**Rated Output Voltage**  
120  VAC

**High Transfer Voltage**  
127  VAC

**Low Transfer Voltage**  
106  VAC

**Sensitivity**  
Low

Note: Changing the Rated Output Voltage may change the High/Low Transfer Voltages and may take a minute to update.

Figure 4-53 – APC Web Interface

Always click “Apply” where applicable

4. Go to Configuration -> Power Settings. Ensure
  - a. Rated Output Voltage = 120 VAC

- b. High Transfer Voltage = 127 VAC
  - c. Low Transfer Voltage = 106 VAC
  - d. Sensitivity = Low
5. Go to Configuration -> Shutdown Configuration. Ensure all settings match as indicated in the figure below.

## Shutdown Configuration

### Start of Shutdown

**Low Battery Duration**

02  minutes

**Shutdown Delay**

090  seconds

**Maximum Required Delay**

2 minutes

**Basic Signaling Shutdown**

Enable

**Controlled Early Shutdown**

**Shut down the UPS (after the shutdown delay) when on battery and:**

time on battery lasts longer than

9999  minutes [1 - 9999]

UPS runtime remaining is less than

2  minutes [1 - 9999]

Battery Capacity Less Than

10  % [5 - 95]

The load percentage on the UPS is less than

10  % [5 - 95]

Stay off after power returns

Figure 4-54 – APC Web Interface

**Duration of Shutdown**

**Sleep Time**  
 hours [0 to 359.9]

**End of Shutdown**

**Minimum Battery Capacity**  
 %

**Return Delay**  
 seconds

**PowerChute Shutdown Parameters**

**Maximum Required Delay**

2 minutes  
 Force negotiation

**On-Battery Shutdown Behavior**

Restart when power is restored  
 Turn off and stay off  
 Ignore PCNS shutdown commands

**User Name**

**Authentication Phrase**

Figure 4-55 – APC Web Interface

6. Go to Configuration -> UPS Configuration and ensure the following settings:
  - a. UPS Name = Building Code followed by UPS (i.e. K805 UPS)

- b. Audible Alarm = At Power Failure
- c. Last Battery Replacement = should be the date of the battery replacement, if known. If it is unknown, set it to the date of installation if the UPS is a brand new install

**UPS Configuration**

**UPS Name**

K805 UPS

**Audible Alarm**

At power failure

**Last Battery Replacement**

July 2017

**External Batteries**

0

Apply Cancel

Figure 4-56 – APC Web Interface

7. Go to Configuration -> Self-Test Configuration and ensure Never is selected

## Self-Test Schedule Configuration

Never  
 Every 7 Days  
 Every 14 Days  
 UPS Startup

Figure 4-57 – APC Web Interface

8. Go to Configuration -> Scheduling Configuration and ensure there are no shutdowns scheduled

### Scheduling Configuration

Name	Interval	Shutdown Time	Turn Back On	Status
No shutdown scheduled.				

**Configure Scheduled Shutdown**

One-time Shutdown  
 Daily Shutdown  
 Weekly Shutdown [Once a week or every 2 - 4 - 8 weeks]

Figure 4-58 – APC Web Interface

9. Go to Configuration -> PowerChute Clients and add the site's IPDVS server(s) IP Address. If there are other IP addresses, delete all the other IP address that may appear

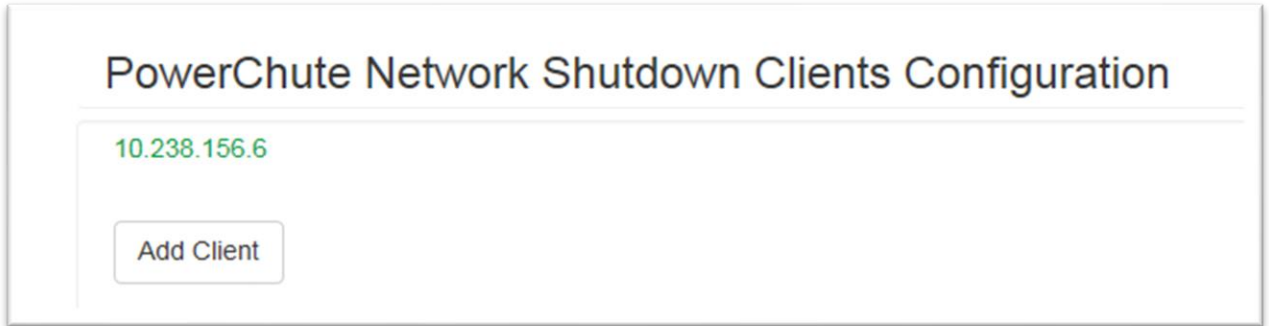

Figure 4-59 – APC Web Interface

10. Go to Configuration -> Security -> Local Users and ensure the “apc” username has the pre-production password set

**User Management Configuration**

**User Configuration**

**Access**  
 Enable

**User Name**  
apc

**Current Password**

**New Password**

**Confirm Password**

**User Description**  
User Description

**Session Timeout** [ 1 to 60 minutes]  
3

**Serial Remote Authentication Override**  
 Enable

**User Preferences**

**Event Log Color Coding**  
 Enable

**Export Log Format**  
 Tab  
 CSV

**Temperature Scale**  
 US Customary  
 Metric

**Date Format**  
mm/dd/yyyy

**Language**  
English

Next >> Cancel

Figure 4-60 – APC Web Interface

### Setting up UPS with Lenovo Servers

1. Before you begin, ensure the server's network connection and IMM is properly confirmed and accessible.
2. As you normally would, assign the proper IP Address to the APC UPS
  - a. Install the Device IP Configuration Wizard
  - b. Run the Device IP Configuration Wizard to find and assign IP address
3. Via the web browser, login to the UPS and continue to configure with the standard settings
  - a. It may look a little different than the Standards because you are using the web interface rather than the dedicated software, but all settings can be configured via the web
4. Go to Configuration -> PowerChute Clients and add the server's
5. Install the APC PowerChute Network Shutdown software. This software will communicate between the server and the UPS regarding when to shut down and current status
  - a. Installation file located:  
C:\IPDVS Software\APC Software\pcns430win-x86-64\Windows\_x64\Setup-x64.exe
6. Go to Start and search for and open **PowerChute Network Shutdown**
  - a. Doing so will open an Internet Explorer window
  - b. Continue to the website
  - c. When you get to the APC login screen, login
7. Next, go to the Configure Events page
8. Make sure all "Logging" are checked (green check mark)
  - a. If it's not checked, please check them
9. Now, check the following with the Enable Shutdown option checked and the Delay listed below:
  - a. **UPS On Battery**
    - i. Delay: **300** Seconds
  - b. **Battery Discharged**
    - i. Delay: **15** Seconds
  - c. **Communication lost while on Battery**
    - i. Delay: **60** Seconds
  - d. **UPS Temperature Overheated**
    - i. Delay: **300** Seconds
10. Now go to the "Shutdown Settings" on the left navigation
11. Ensure that in the "UPS Shutdown" section, the "Do not turn off the UPS" is selected
12. Now go to the "Communications Settings" on the left navigation
13. Fill out the required information if it was changed from default
14. Now restart the server. After booting up and logging into Windows, allow 10-15 to ensure that the server does not auto turn off

This is the "PowerChute Network" shortcut in Windows Start Menu



Figure 4-61 – APC Software

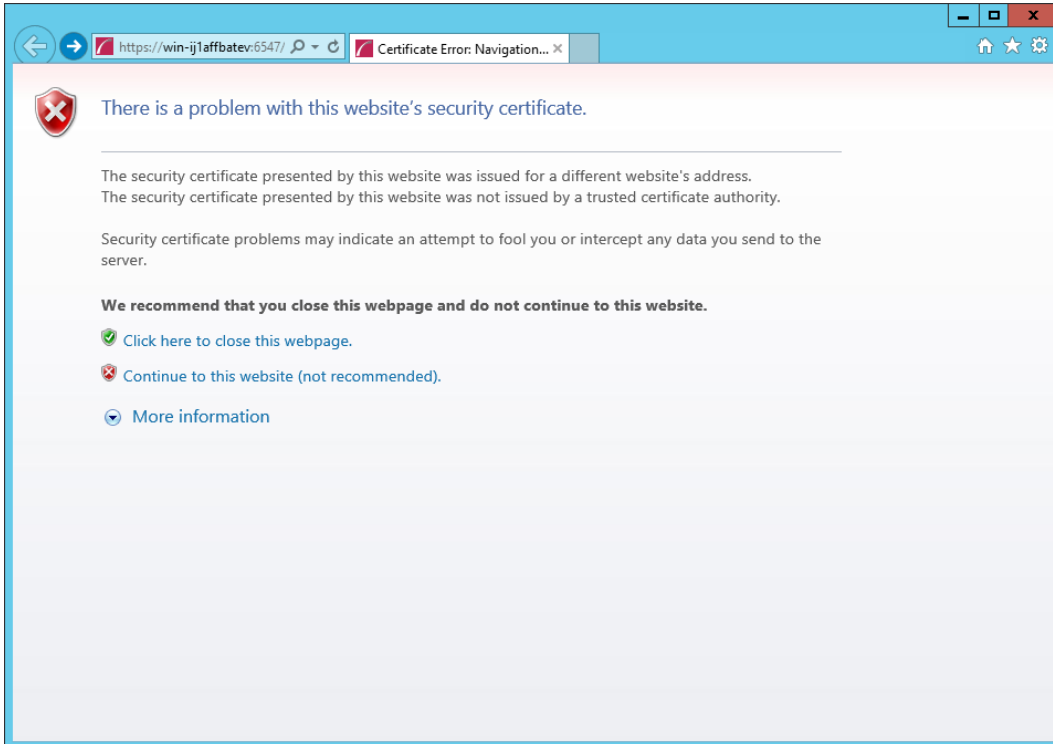

Figure 4-62 – APC Software

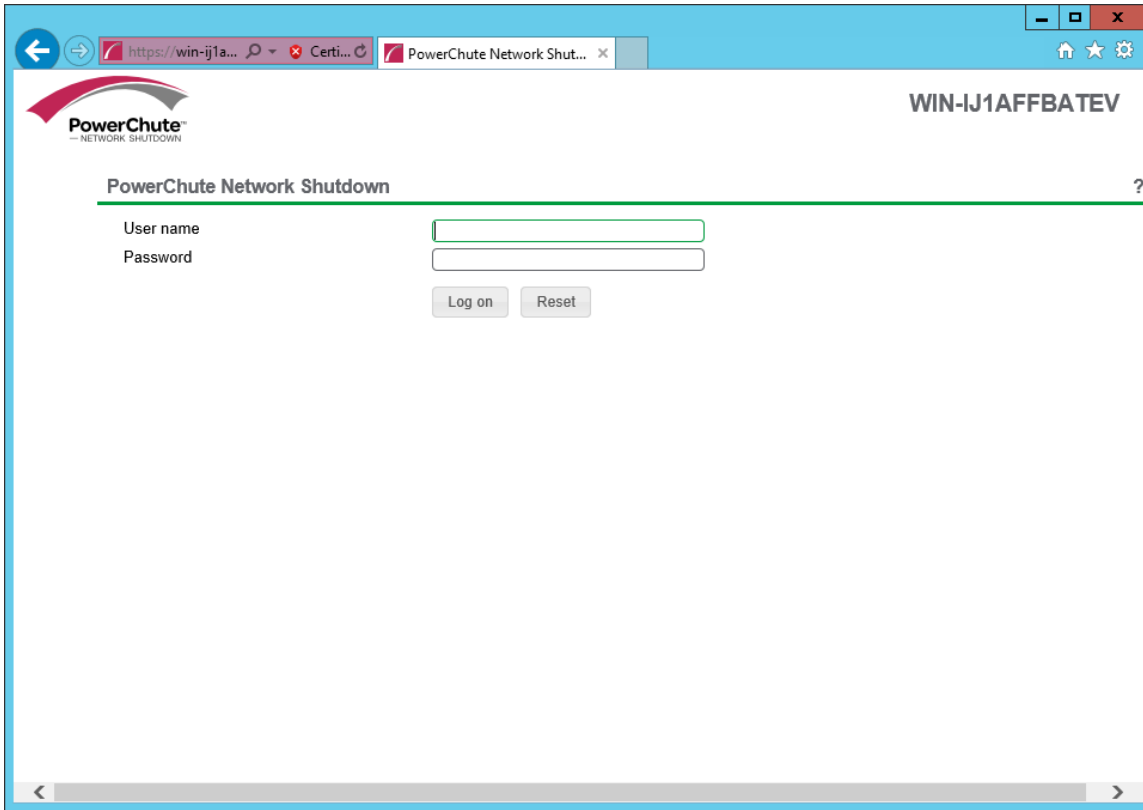

Figure 4-63 – APC Software

Refer to Step 9 above for the below configuration

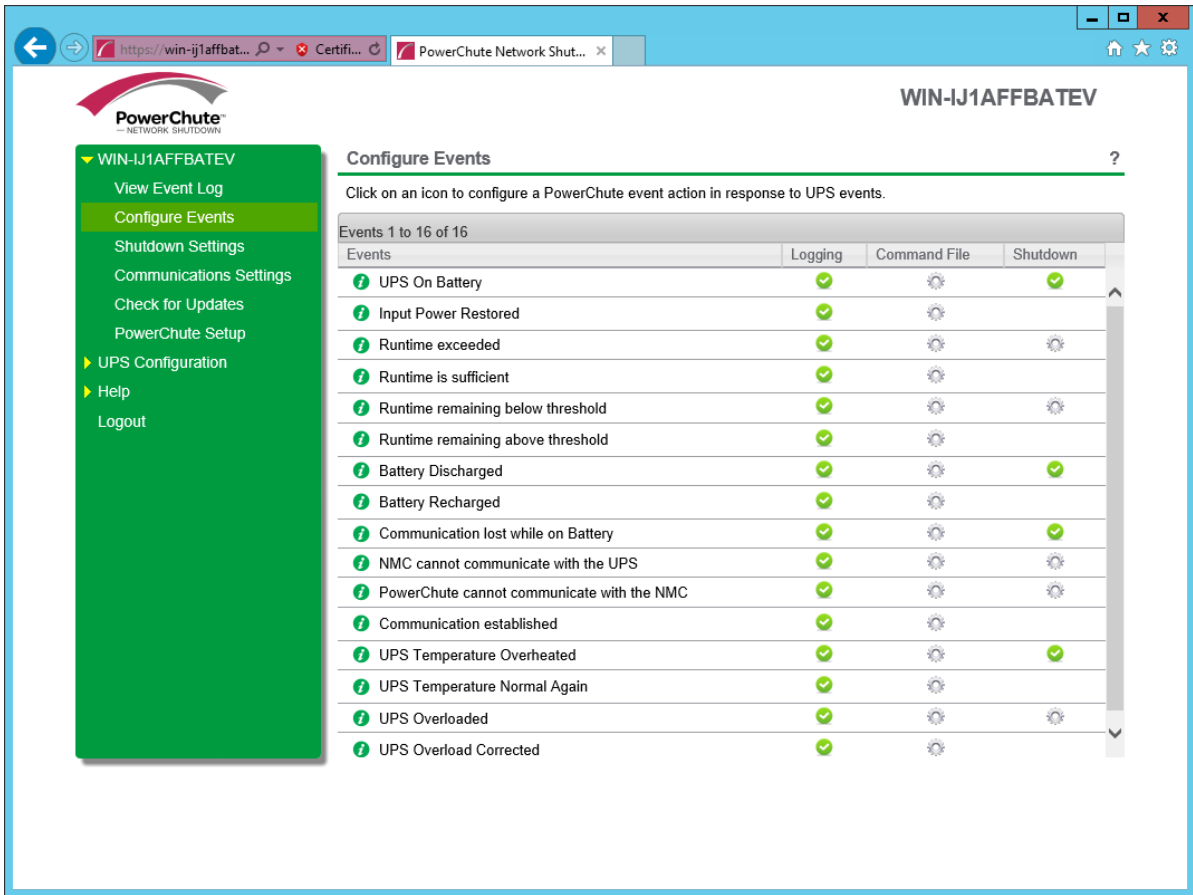

Figure 4-64 – APC Software

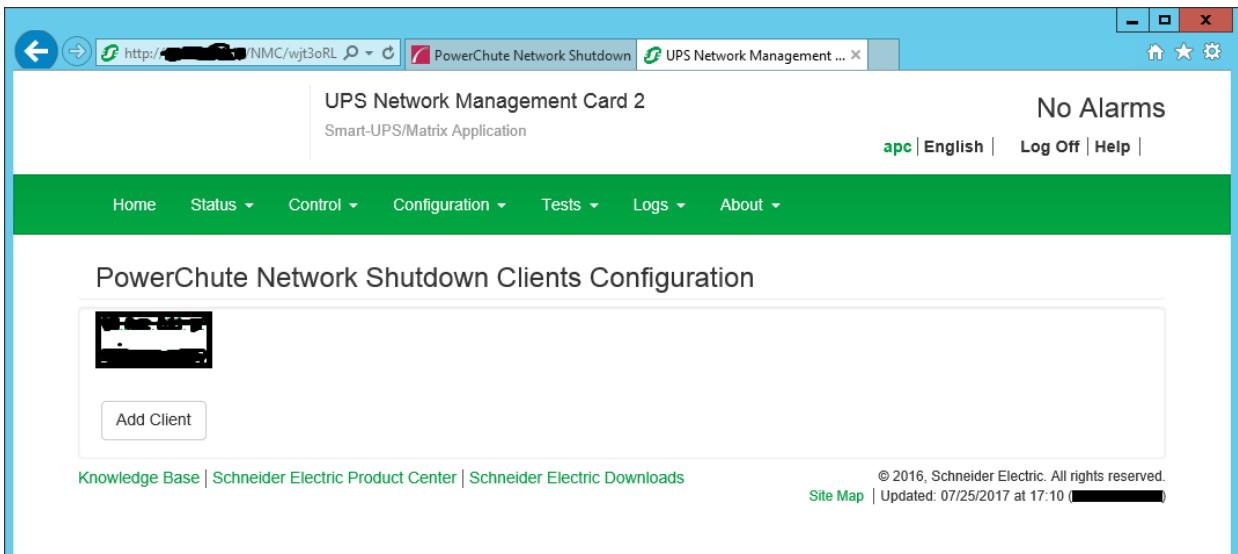

Figure 4-65 – APC Software

In the “Add Client” option, the primary server and secondary server IP should be populated.

\*\* Note: secondary server applies only when there are 2 IPDVS Servers at the site

## Security Center Set Up

### INSTALL, LICENSE AND CONFIGURE GENETEC SECURITY CENTER

These tasks will set up the Security Center Server.

#### Install Security Center 5.9 Server (single server - 96 Camera Maximum)

The procedures in this section will install the Security Center 5.9 server application only for a single server site with 96 cameras as a maximum for each server. The next section depicts a dual server site procedure.

**Note:** When planning a dual server site, here are some items to consider:

- Primary server functions as the Directory Server Role & Archiver Role
- Secondary server functions as an additional Archiver Role
- To balance resources between both servers, add more cameras on the Secondary server (2<sup>nd</sup> Archiver) since it only has one role

**Example:** If a site has 150 cameras, consider adding 65 – 70 cameras on the Primary server and 80 – 85 on the Secondary Server (40% - 60% respectively)

- 1) Open **Windows Explorer** and browse to the folder:
- 2) C:\IPDVS SOFTWARE SC 5.9.2.1
- 3) Double-click **setup.exe**

### Description

Genetec Security Center 5.6 SR4 K12 is being replaced with Genetec Security Center 5.9.2.1 and will run on an updated image of Windows Server 2016 Datacenter. Windows Server 2012 is being replaced by Windows Server 2016. Genetec Security Center 5.9 will also be able to run on existing Windows 2012 Servers, should the need arise during Genetec Security Center upgrades or break/fix.

Guidance is available if needed by calling the IPDVS Deployment team at (718) 935-4800 or emailing [&IPDVSDeployment@schools.nyc.gov](mailto:&IPDVSDeployment@schools.nyc.gov)

### Specific Changes: This is the newest version of the IPDVS Standards

- 1) **For Both OS (Windows Server 2016) and Genetec Security Center (5.9.2.1):** Significant changes have been made to add complexity to passwords being used by requiring at least (1 or more uppercase letters, 1 or more lower case letters, 1 or more numerical characters, 1 or more special characters) thus creating a new pre-production password.
- 2) **OS:**
  - a) Windows Server 2016 specific change is the desktop view that mimics a Windows 10 Desktop. When clicking on the windows start flag you see Microsoft has brought

- back the Classic Windows Desktop view on the Server OS. The Desktop view in Windows Server 2012 was tile based when clicking on the start menu.
- b) Run the IPDVS PowerShell Script after server is on VLAN 470.

3) **Genetec Security Center 5.9.2.1:** Updated setup procedures on installing and configuring the new Genetec Security Center are depicted below.

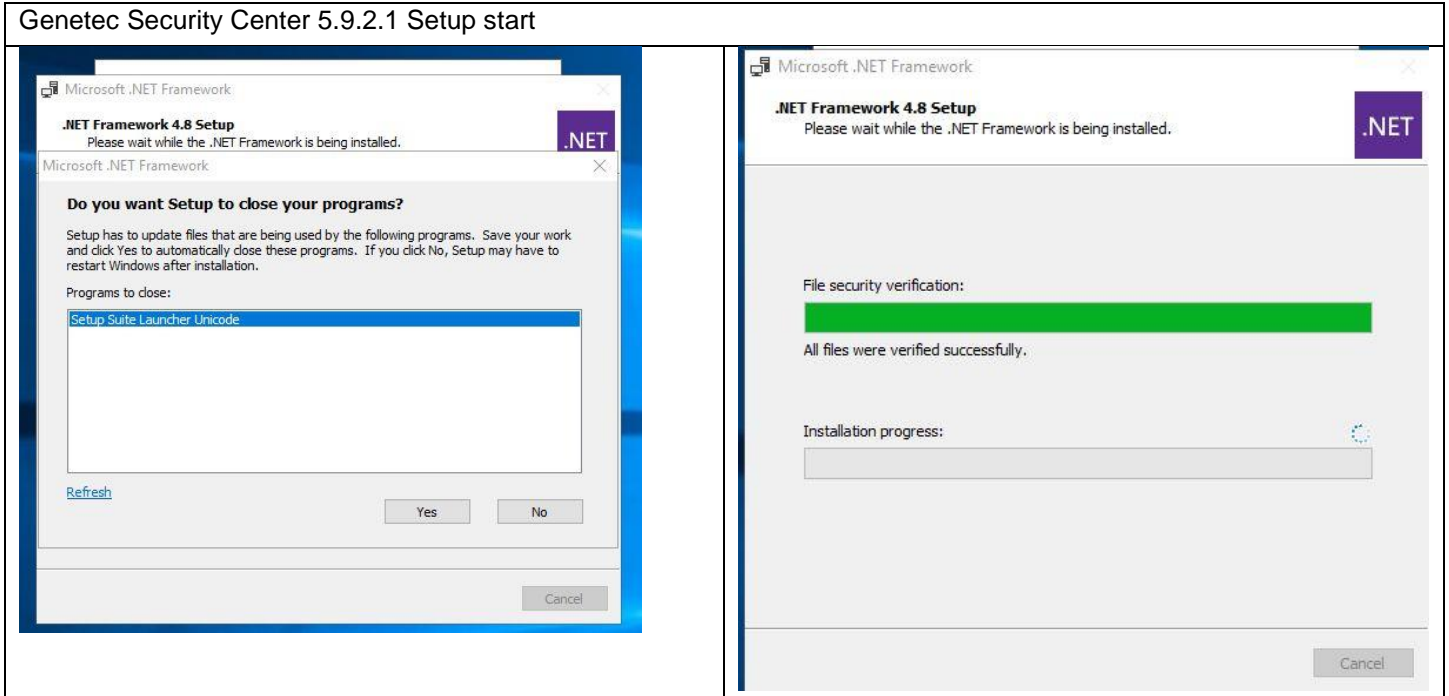

Genetec will prompt to install .NET 4.8 Framework if it is not installed. Follow the onscreen instructions to install. After installation is complete, reboot server.

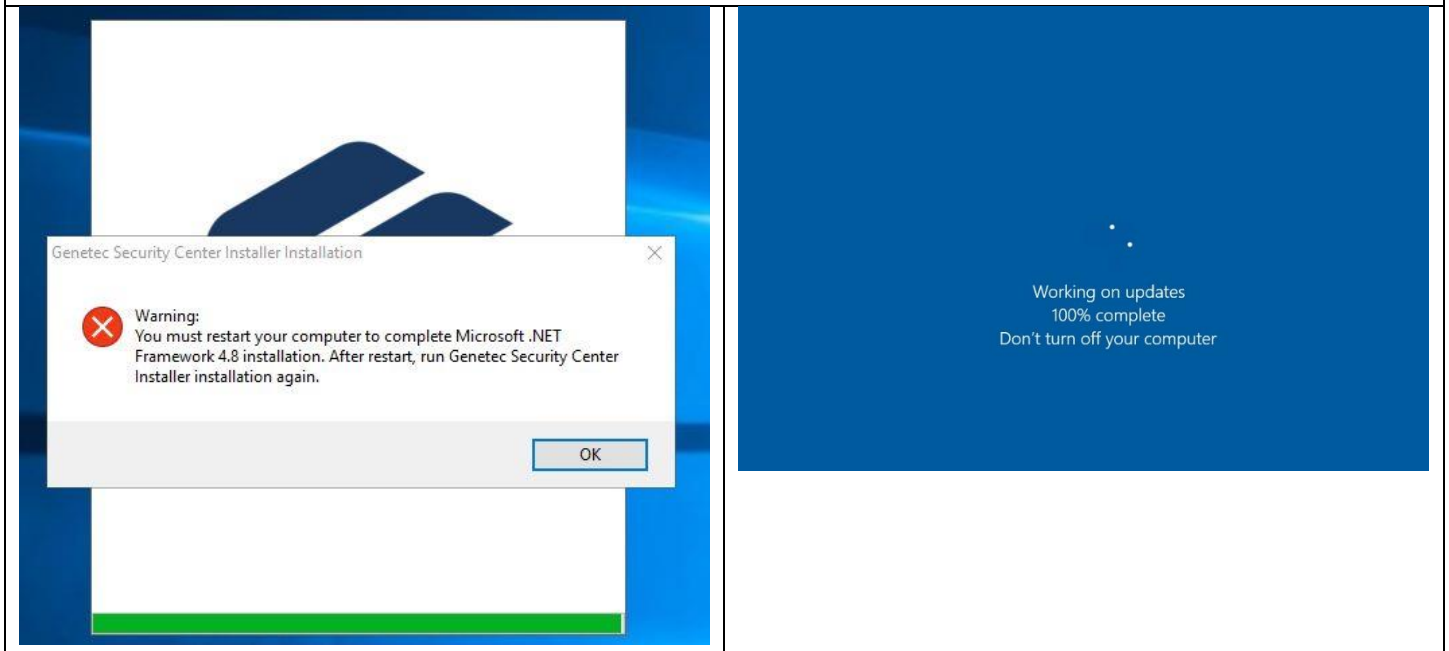

After server has been rebooted, restart Genetec 5.9 Setup again. Follow the onscreen guide depicted below.

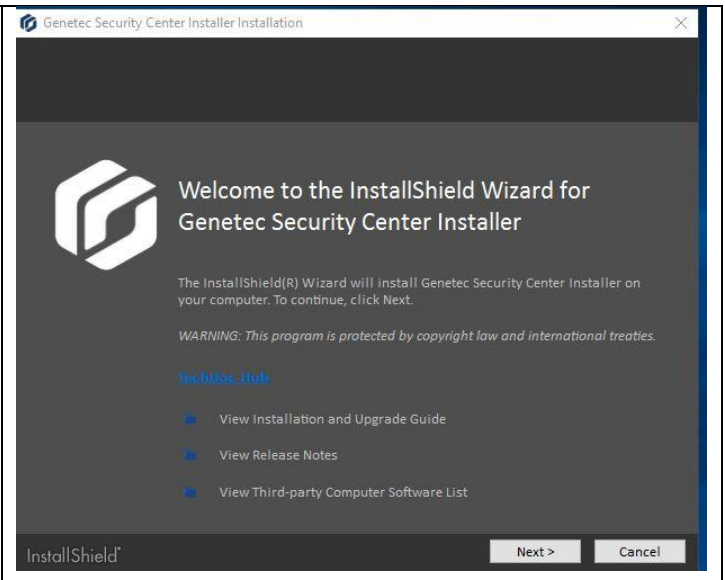
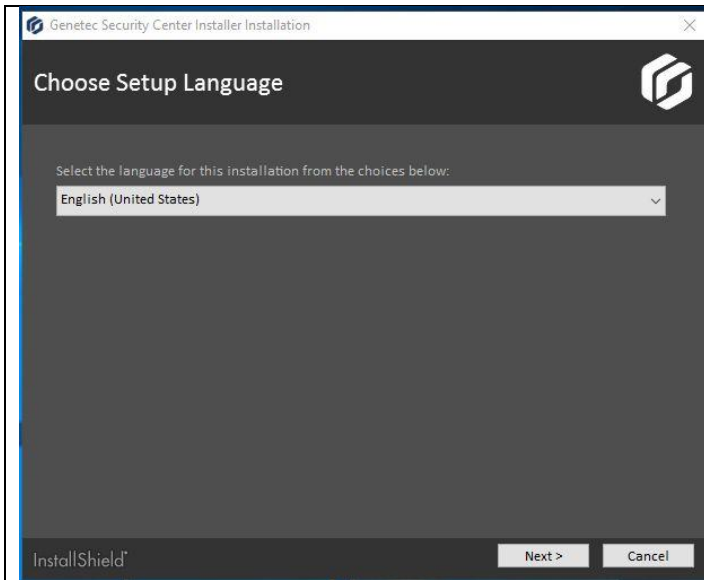

Accept the terms, click next.

For Server installation, choose Client and Server as shown below.

For Desktop installation, only choose Security Desk.

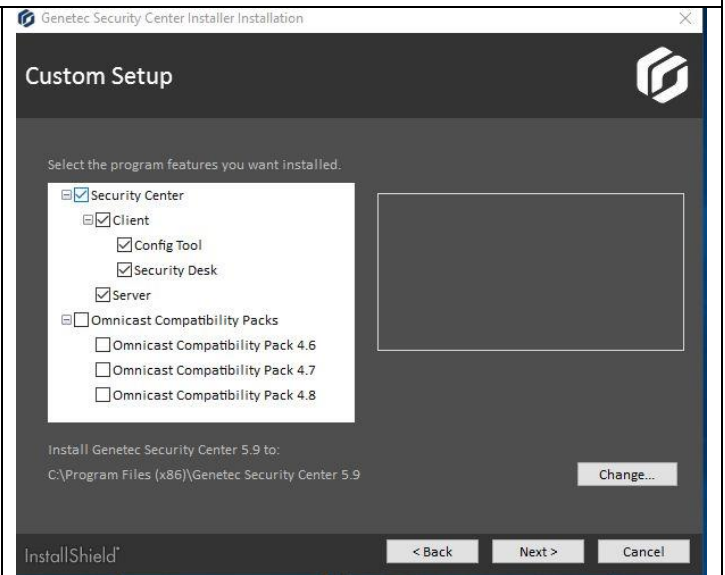
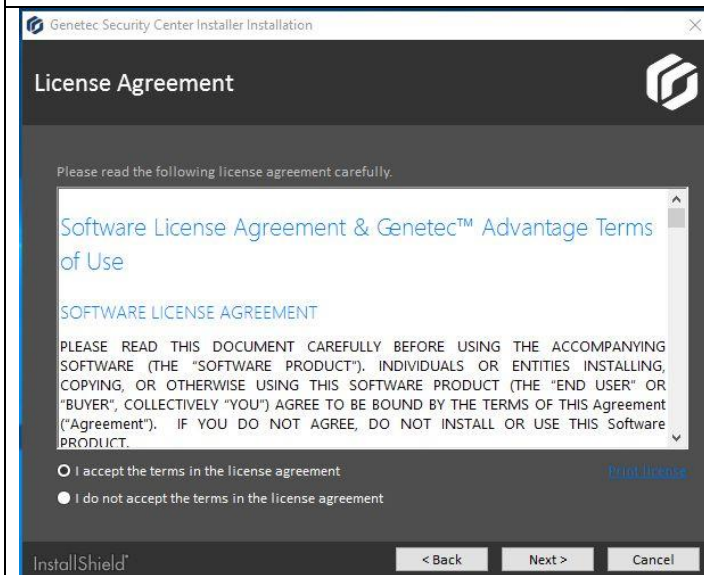

Choose Main Server for 1<sup>st</sup> server at site.

If site has 2 Servers, then on 2<sup>nd</sup> server setup, choose Expansion server option under the 2<sup>nd</sup> server installation.

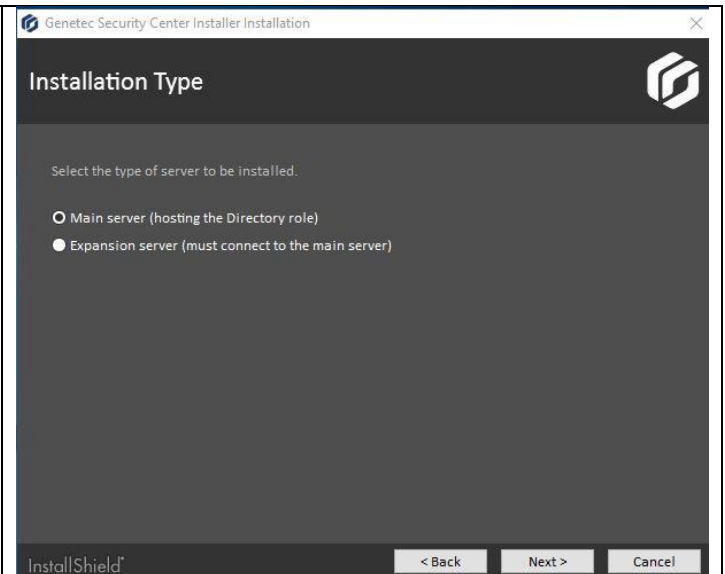

Choose No, on the participation of helping to improve products.

SQL should already be installed on server, therefore installation defaults to "local" as shown in the screenshot

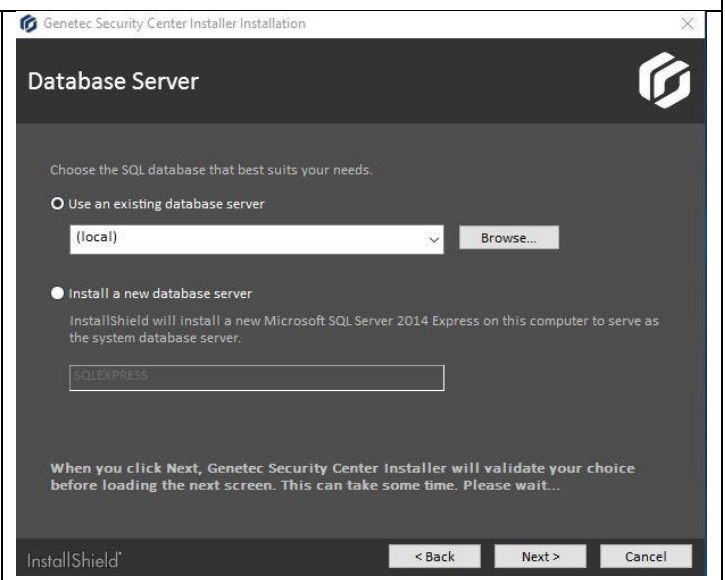
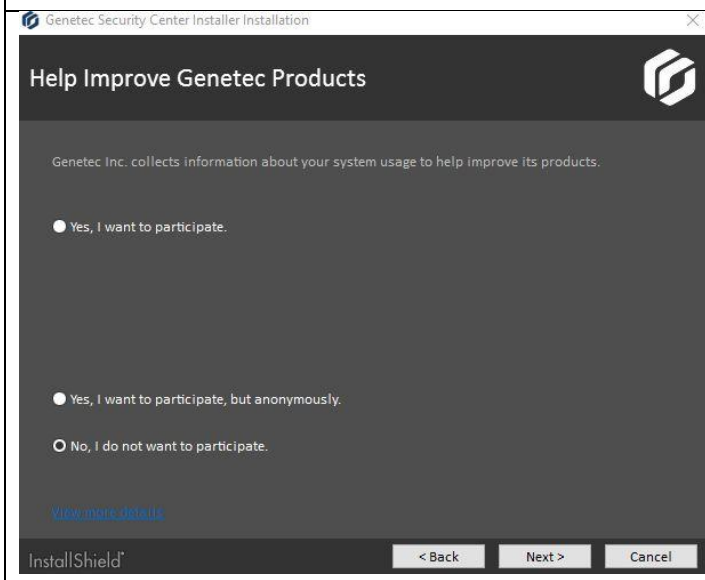

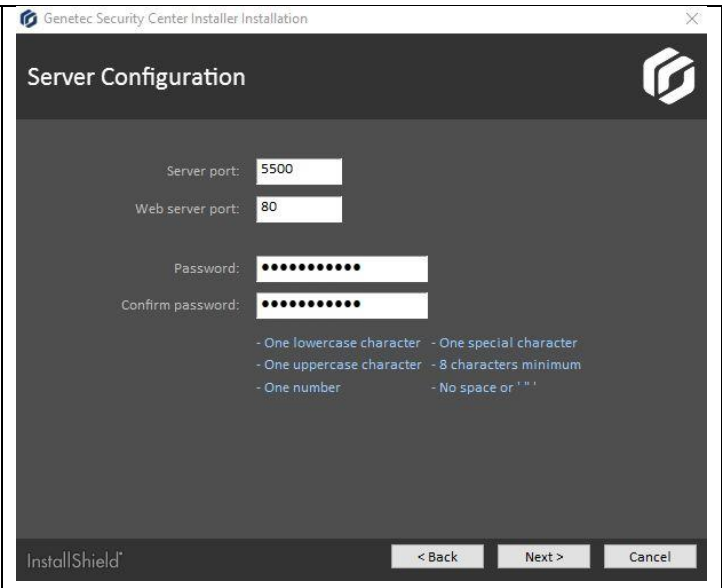
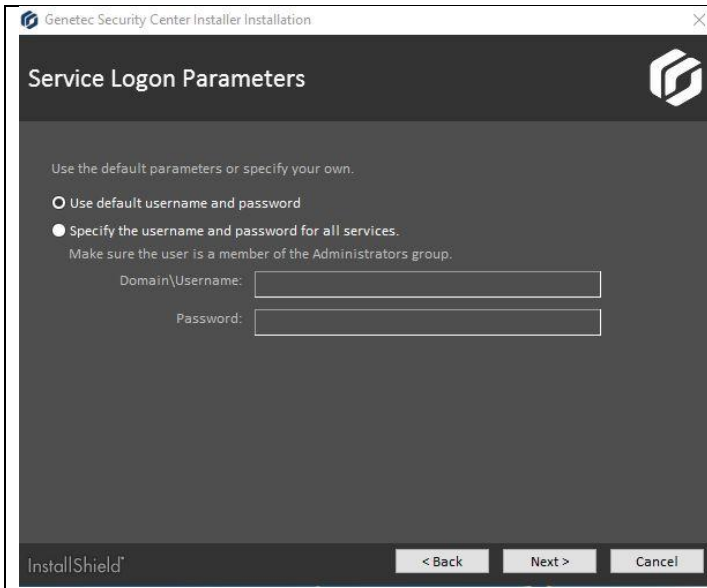

Choose “default username and password” option, click next.

Leave ports on default and set password to the pre-production password: P@ssw0rd123 (case sensitive).

Check, allow for Genetec to create necessary firewall rules

Uncheck, install WinPcap

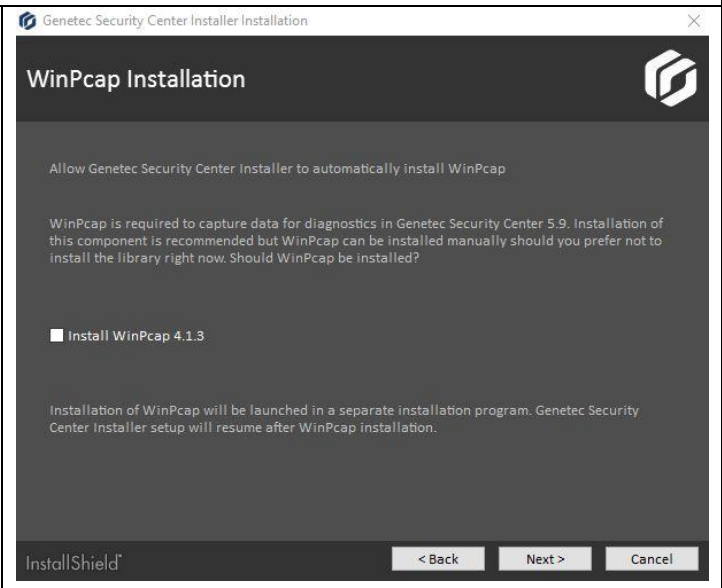
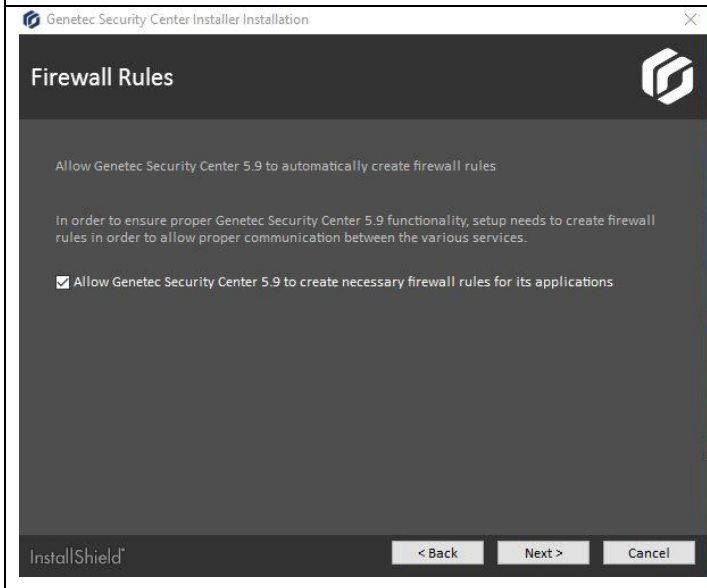

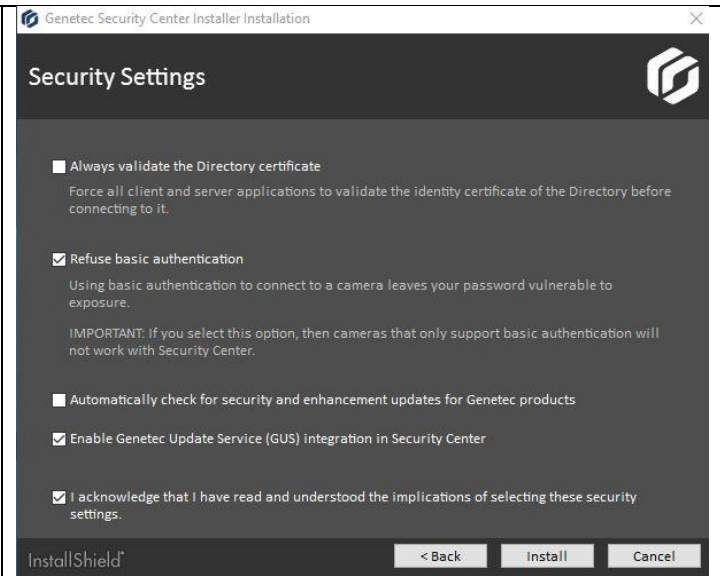
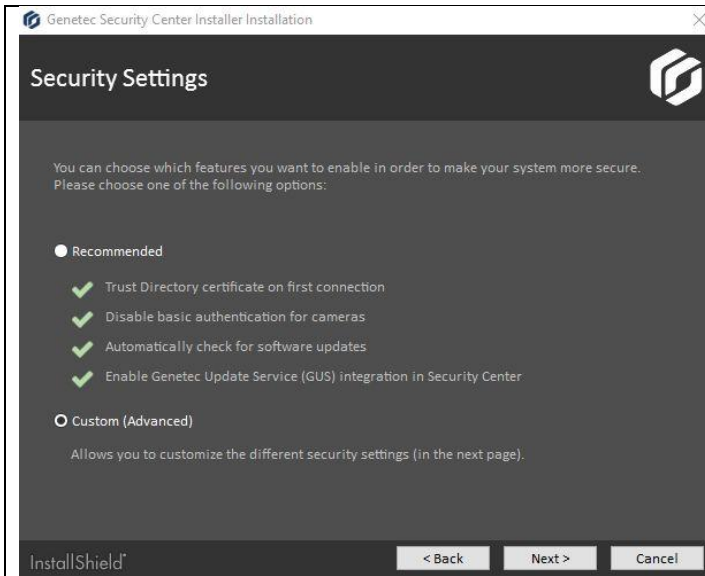

Choose Custom (advanced).

Uncheck, Always valid the Directory Certificate.

Check, refuse basic authentication.

Uncheck, Automatically check for security and enhancement updates for Genetec products.

Check, enable Genetec Update Service (GUS) integration in Security Center.

Check, I Acknowledge that I have read and understood ...

Click install to begin installation.

Only check "Launch Server Admin".

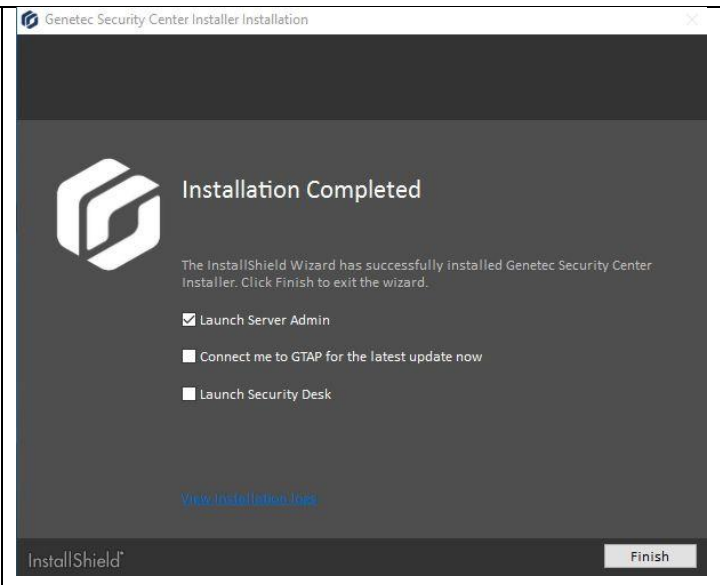
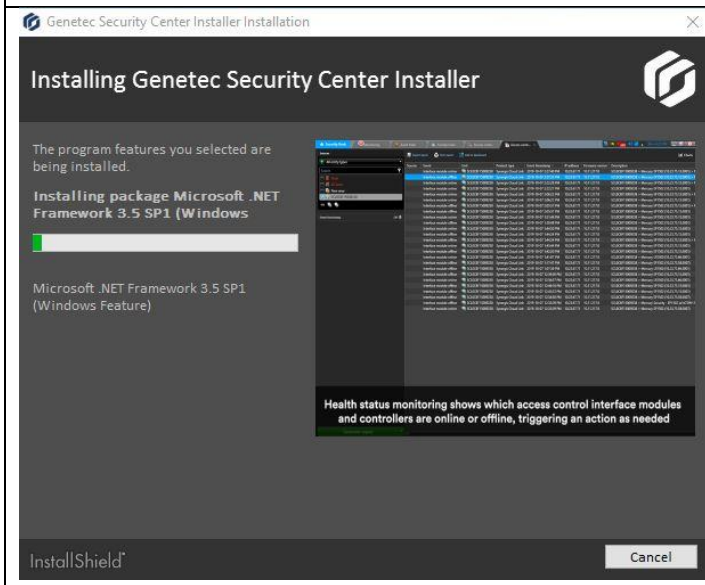

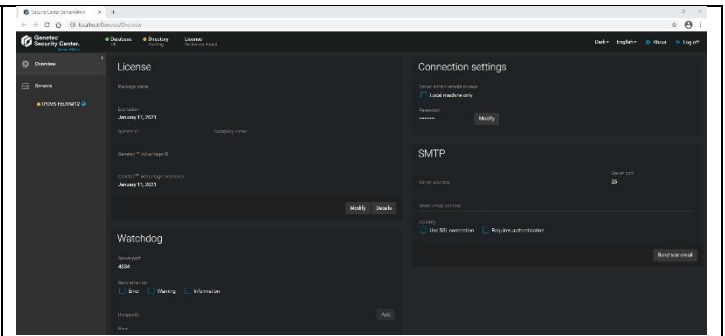
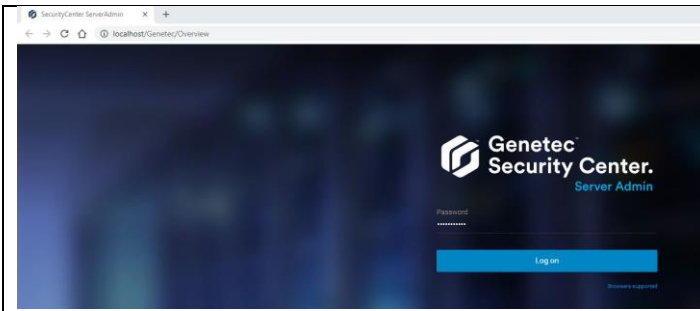

Enter the preproduction password: P@ssword123

Click on License flashing red

Choose Manual activation

Save Validation key

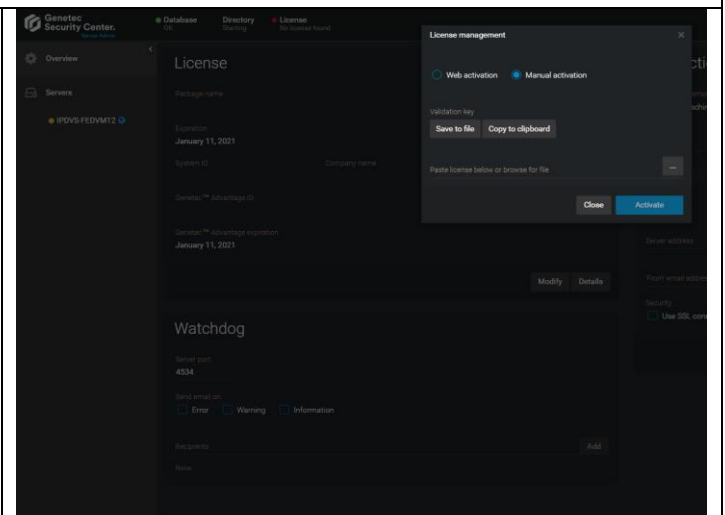
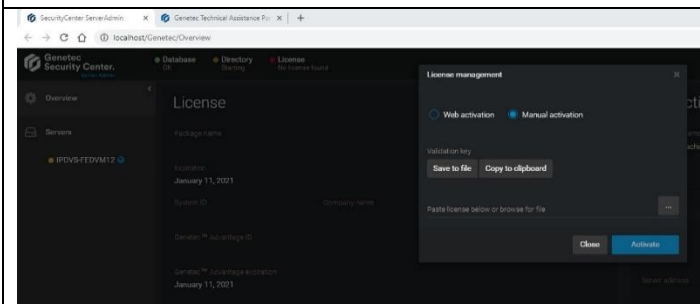

Go to Genetec Licensing Portal, search for license

Click activate, upload the validation key

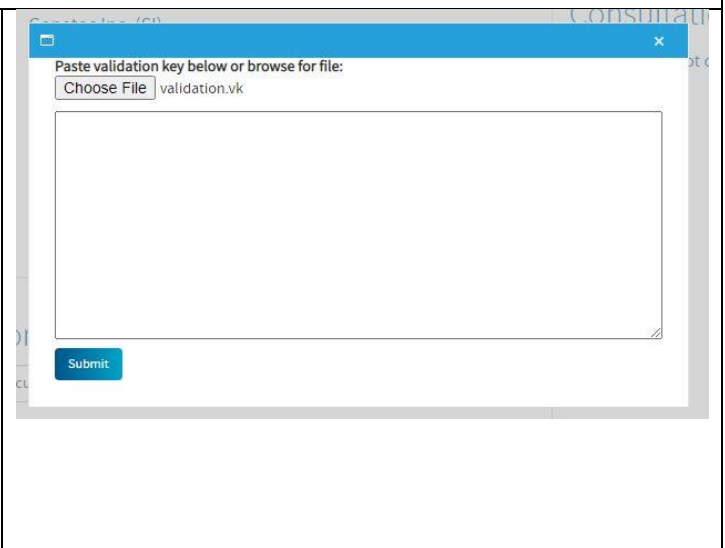
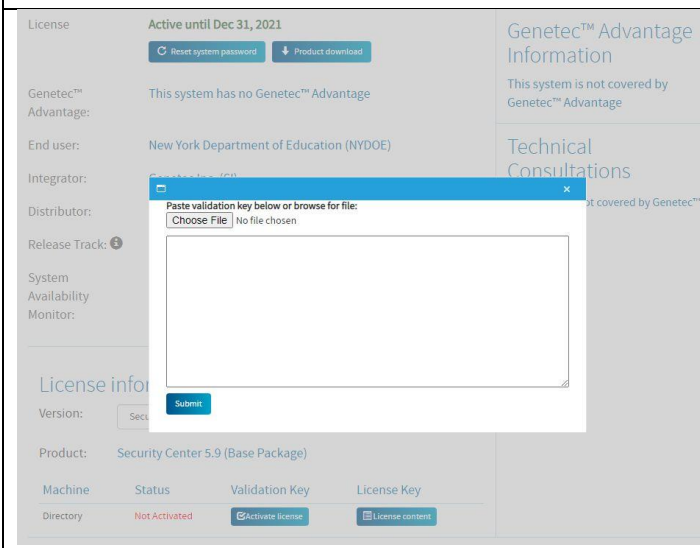

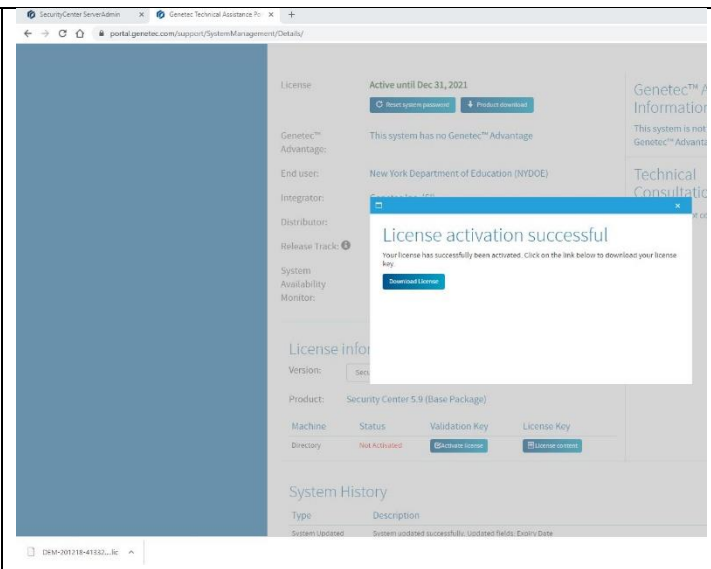
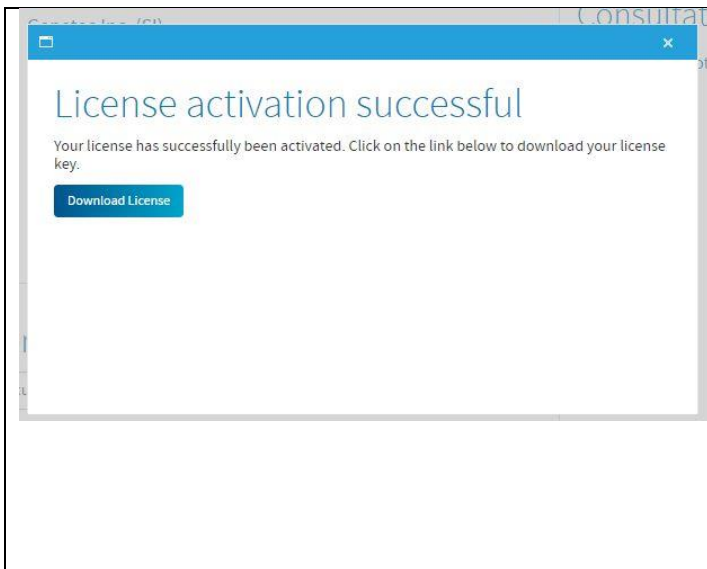

Once Validation key is uploaded, a License activation successful appears  
 Download license key, return to Manual activation and browse to downloaded license file  
 Click on Activate

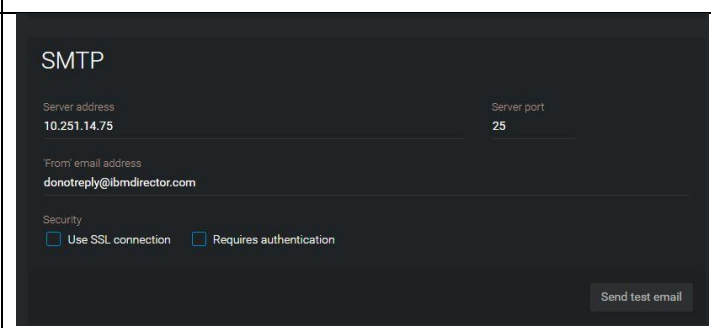
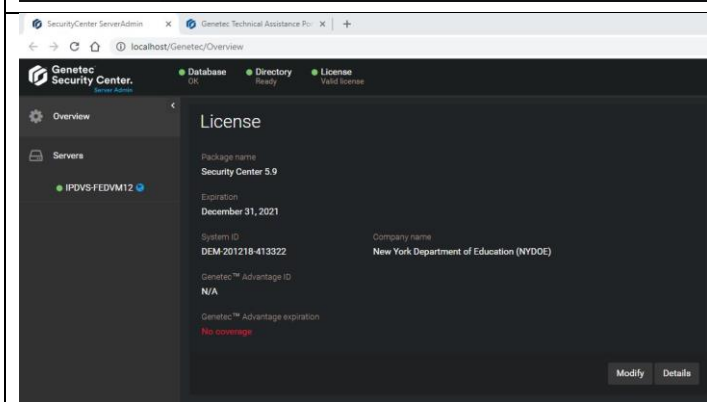
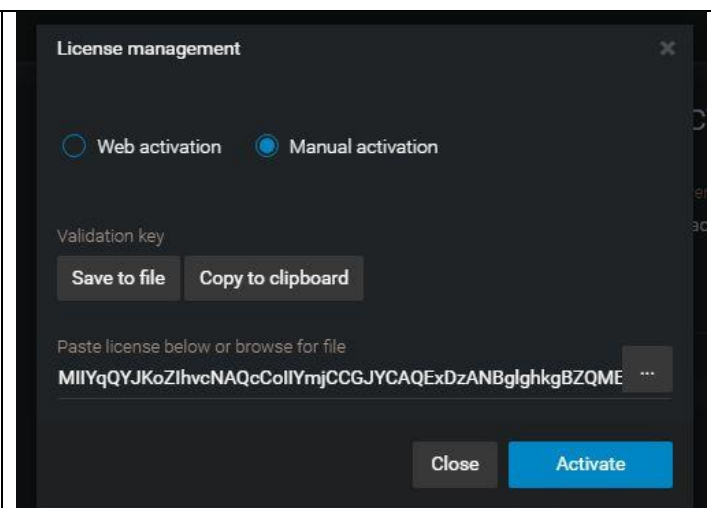
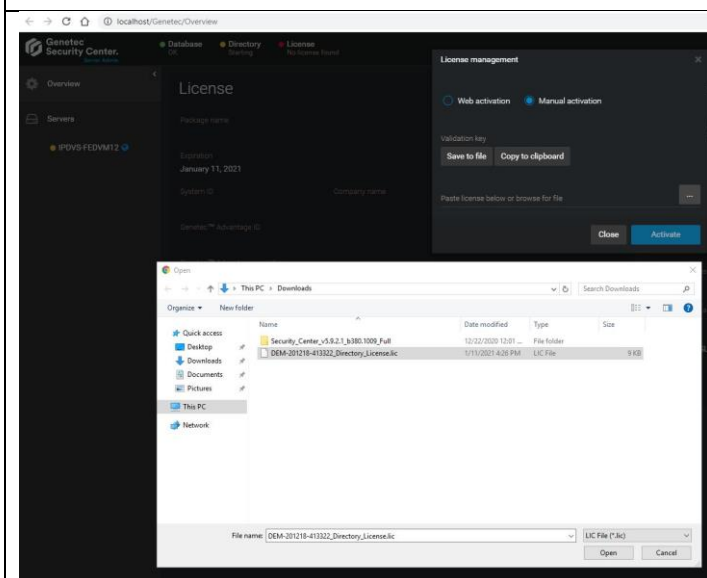

License and Directory turn Green. Server is now Licensed

Enter SMTP IP shown under server address, enter [donotreply@ibmdirector.com](mailto:donotreply@ibmdirector.com) under the from email address

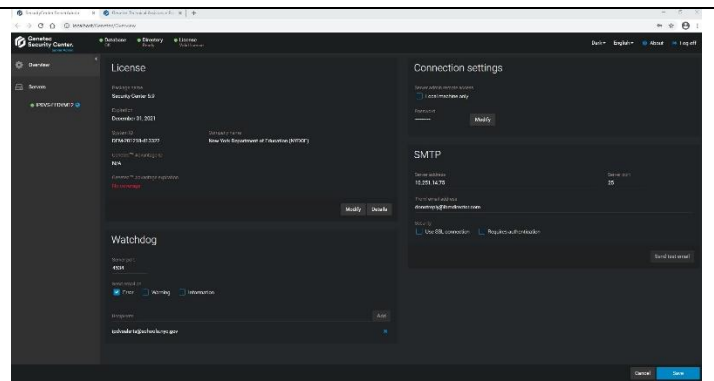
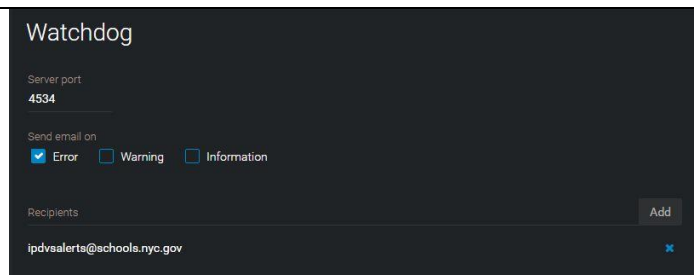

Check only error under the Watchdog  
Enter [ipdvsalets@schools.nyc.gov](mailto:ipdvsalets@schools.nyc.gov) under recipients  
Click on save

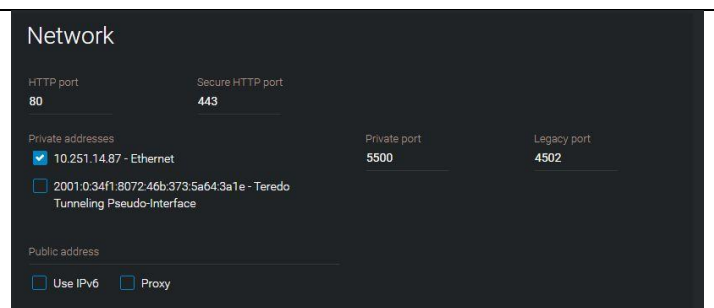
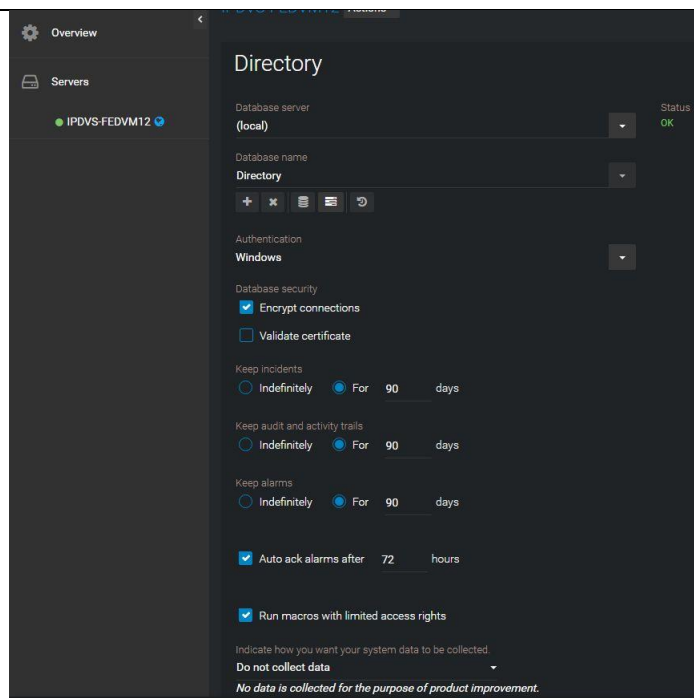

Under Directory, ensure all settings match figure above  
Under Network, only check the Server's IP address  
Click Save, Open Config Tool

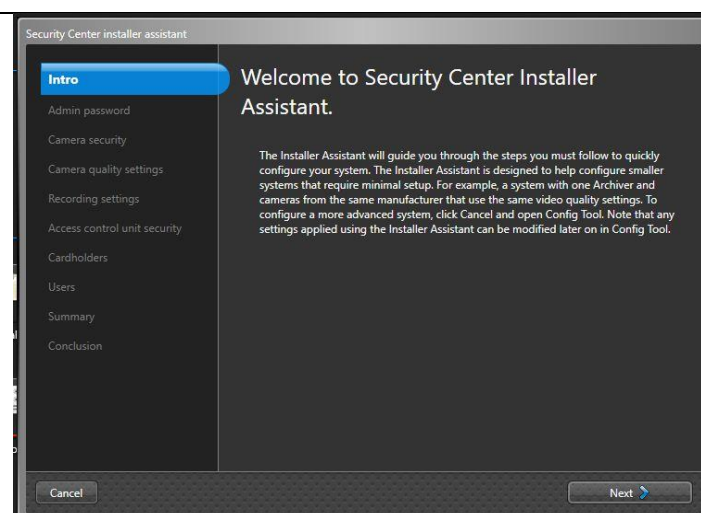
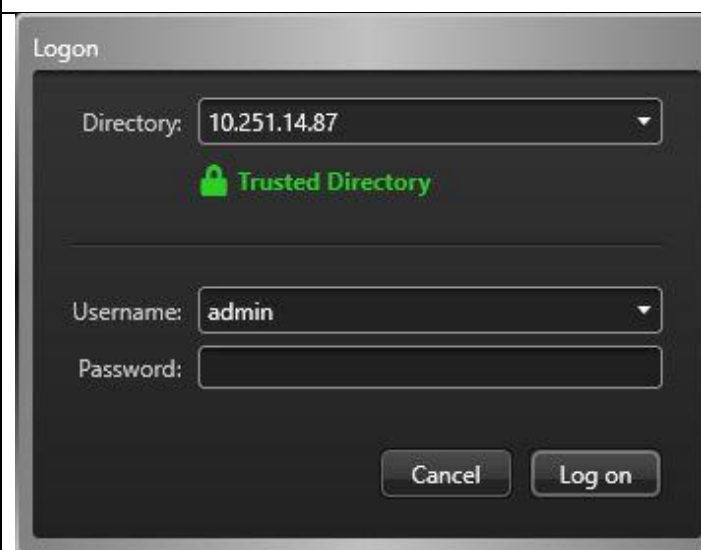
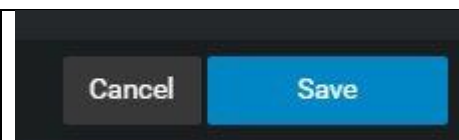

First Login with a blank password, click log on, then next

Set the Admin account password to: P@ssw0rd123

As you type in the password, the yellow requirement warnings will disappear, click next

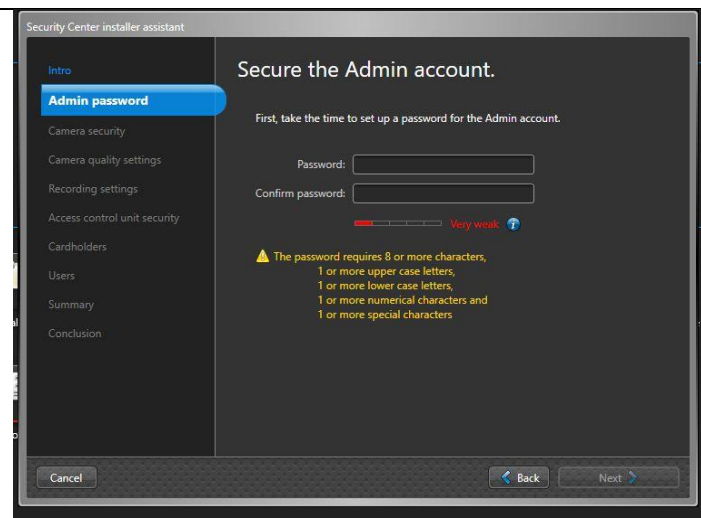
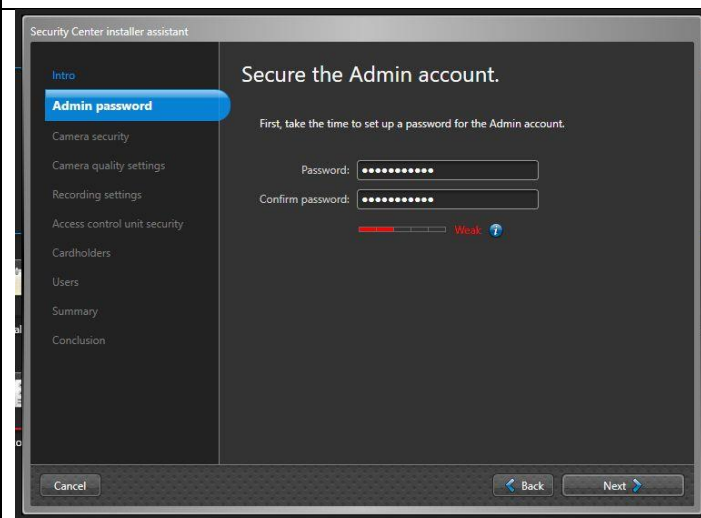

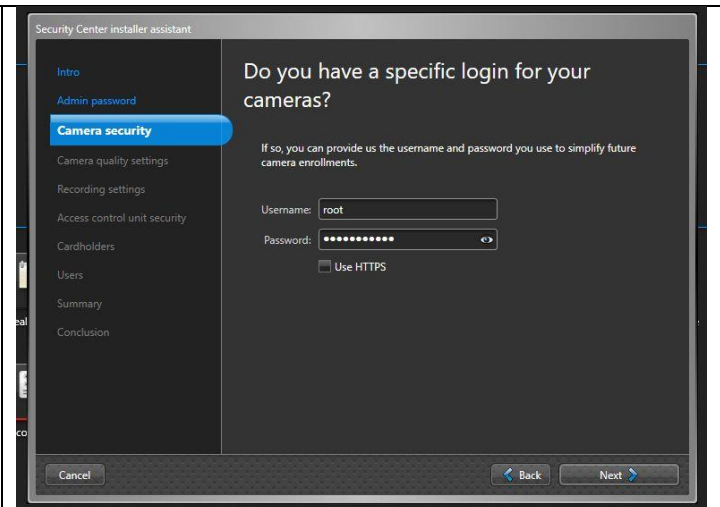
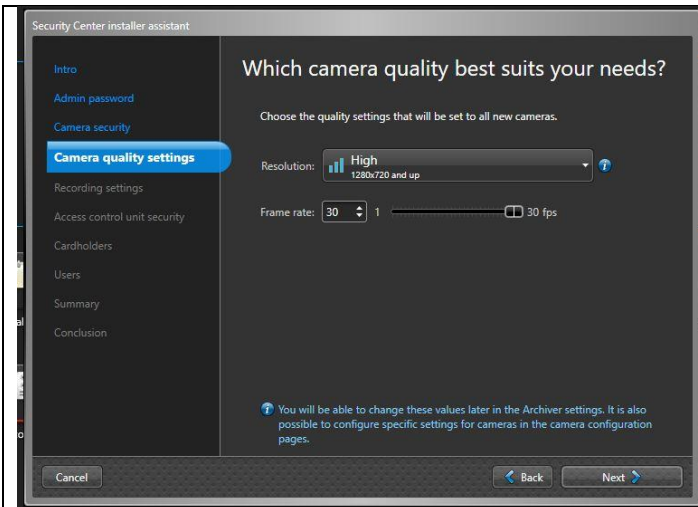

Camera quality settings resolution should be on High and 30 frames per second  
Enter root for username for camera security, password: p@ssw0rd, click next

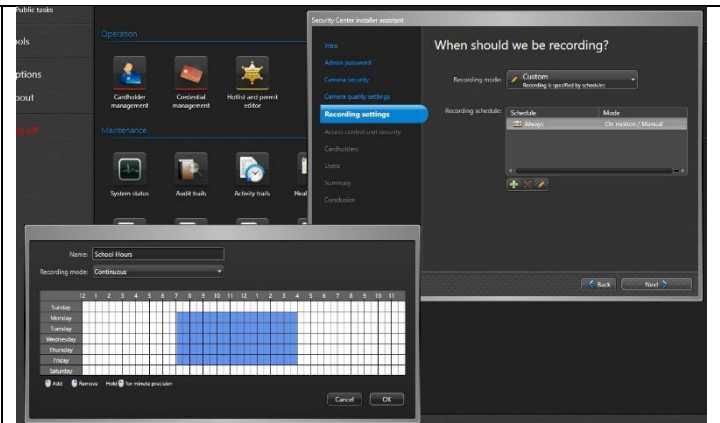
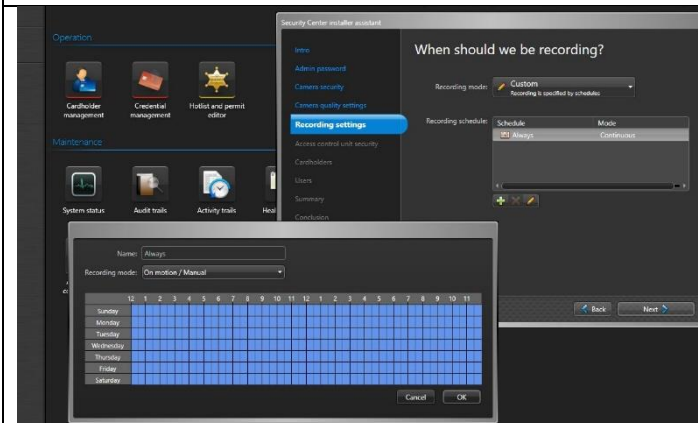

For recording settings, set recording mode to custom. Select Always, click on pencil icon to edit, popup will appear  
Set recording mode to On Motion/Manual, click ok  
Click the plus (+) icon, popup will appear, type in School Hours for Name and recording mode should be Continuous.  
Left click with mouse to fill in 7 am to 4 pm for Monday through Friday, click ok. See below picture for final setting.

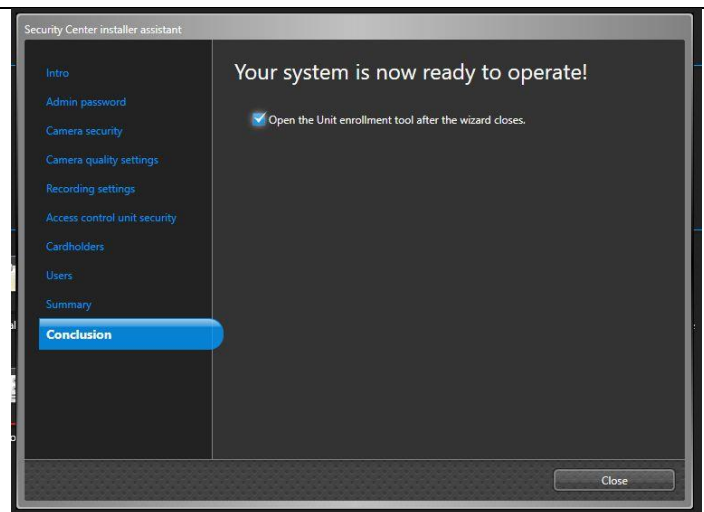
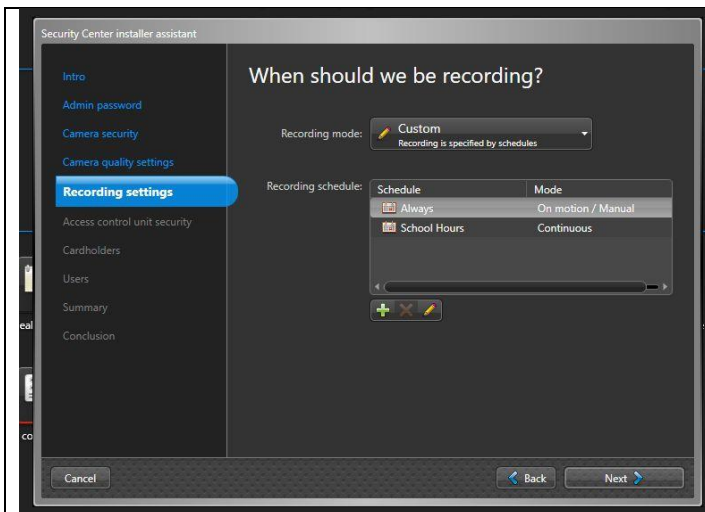

Click next, uncheck Open the Unit enrollment tool and click close to do this at a later time.

Go to Task → System → General Settings

Choose User password settings from the left options, uncheck all the check boxes. Apply changes.

Choose Activity trails from the left options, select all on the bottom and Apply Changes.

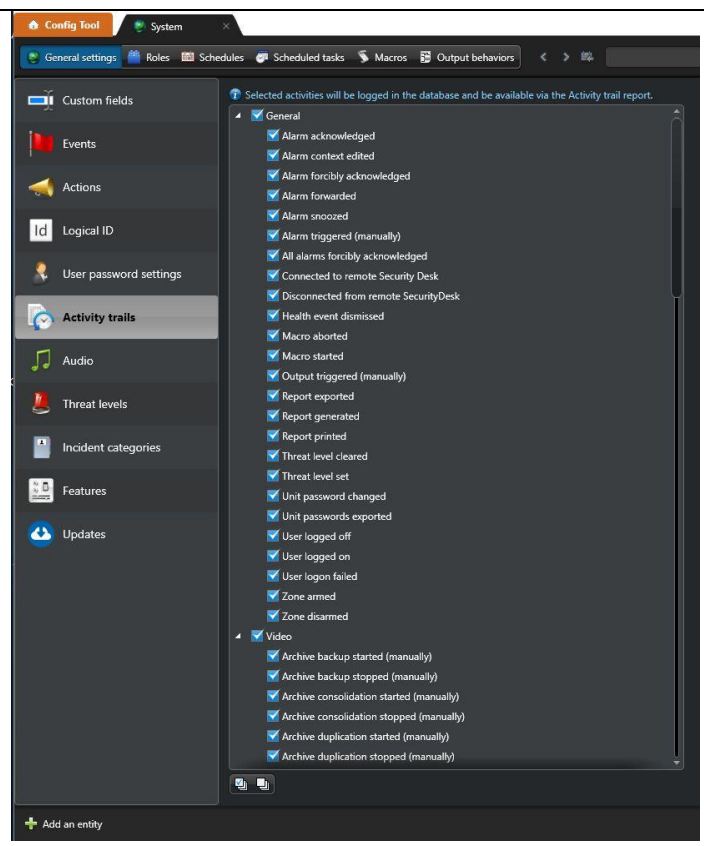
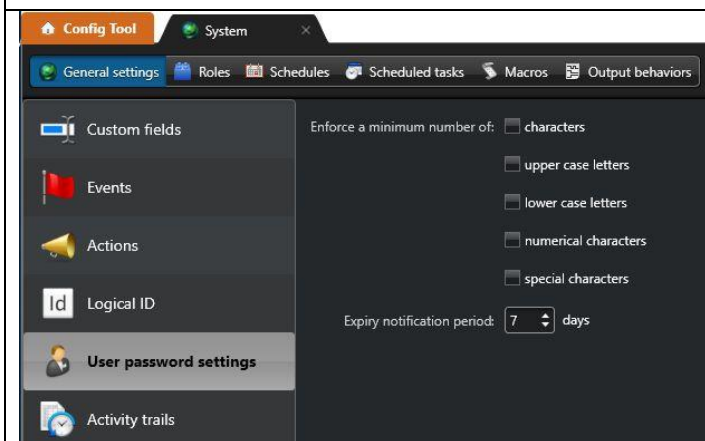

Go back to user management and change Admin account password back to standard pre-production password.

Under User Management -> Administrators group -> Admin account -> Properties -> Change Password

Change the password to pre-production (p@ssw0rd)

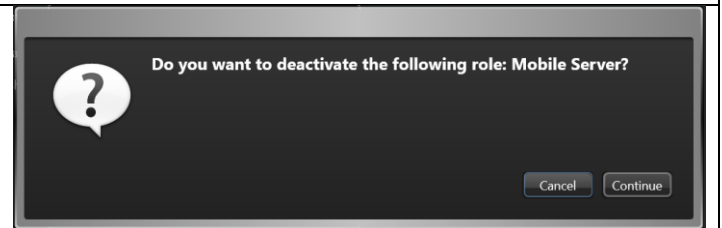
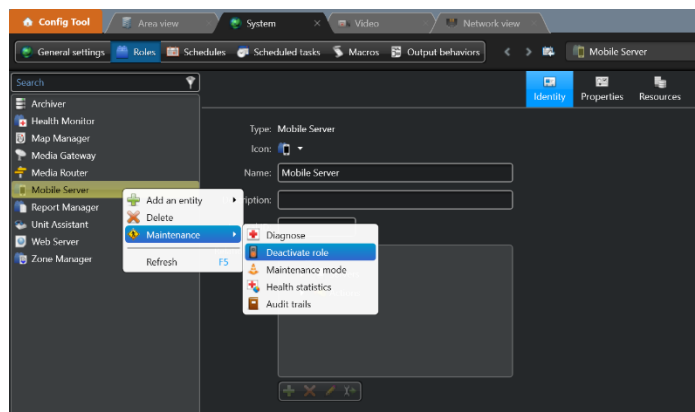
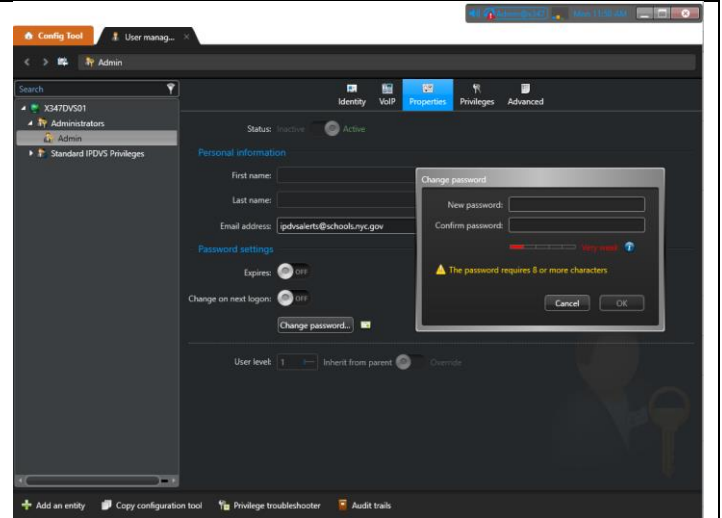

Click on Tasks → System → Roles

Right click Mobile Server. Choose Maintenance → Deactivate Role. On Popup click Continue.

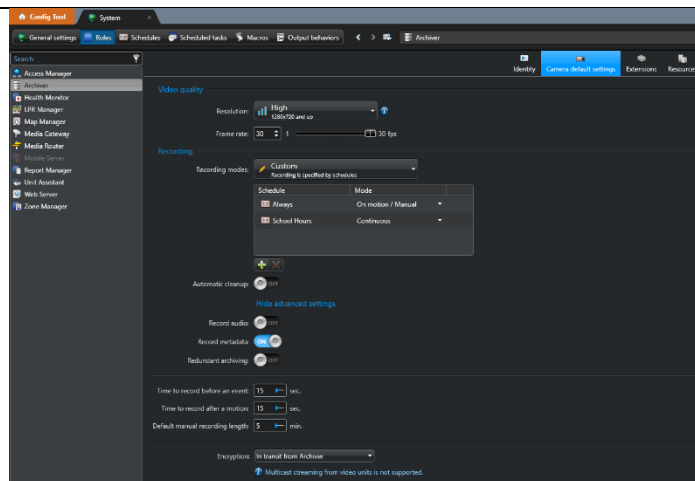

Config Tool → System → Roles → Archiver → Camera default settings → Show advanced settings

Automatic cleanup: off

Time to record before an event: 15 seconds

Time to record after a motion: 15 seconds

Default manual recording length: 5 minutes

Click Apply

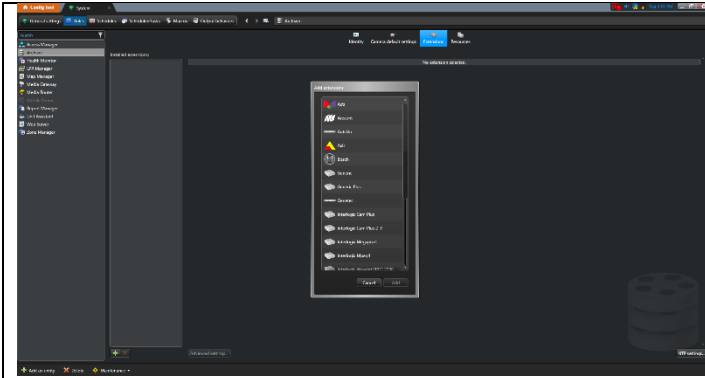

Config Tool → System → Roles → Archiver → Extensions

Click plus (+) icon under installed extensions section

Choose camera or VPU manufacturer, ADD

Under Default logon add username and password of cameras

Click Apply

Choose NTP settings on the bottom right corner

Enter the NTP Server IP that you are given by DIIT

Click OK, Apply

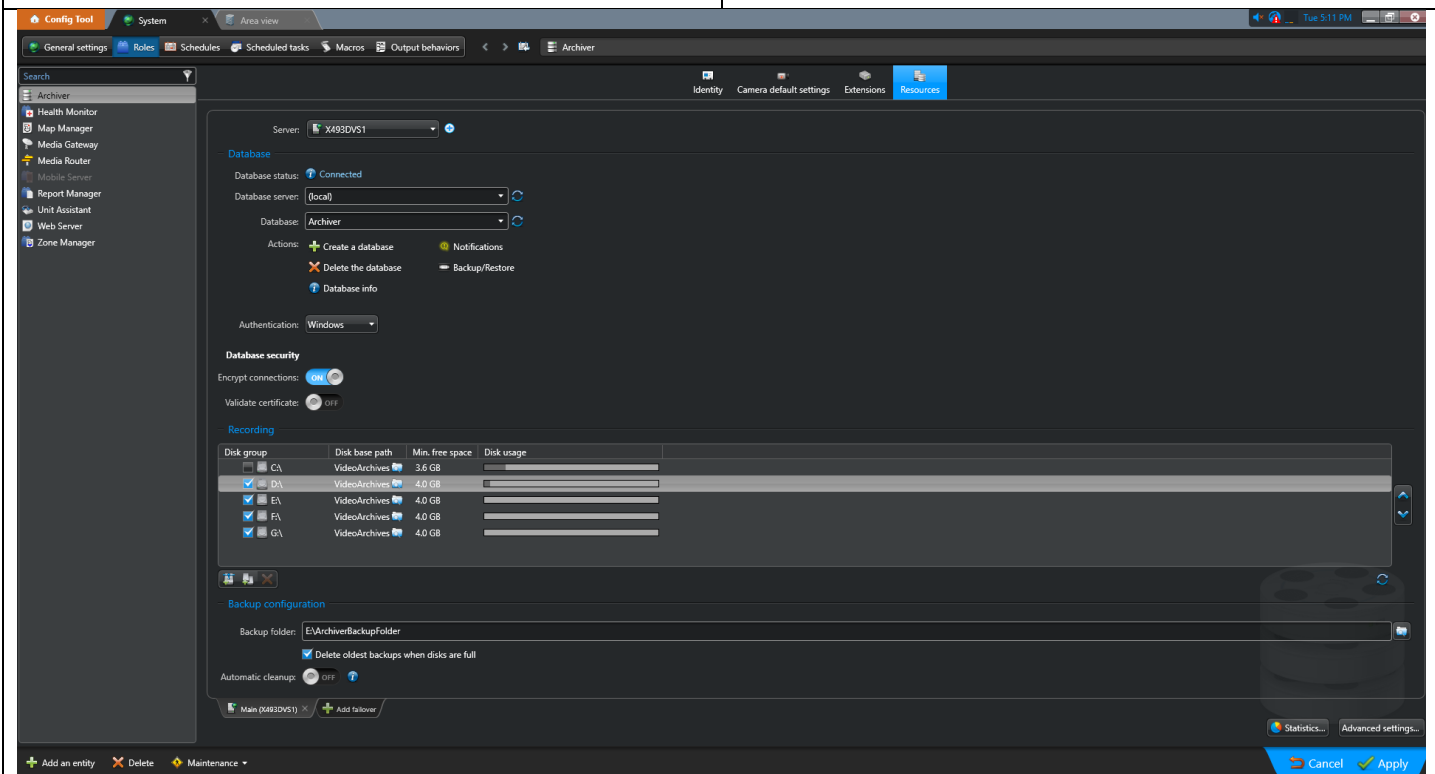
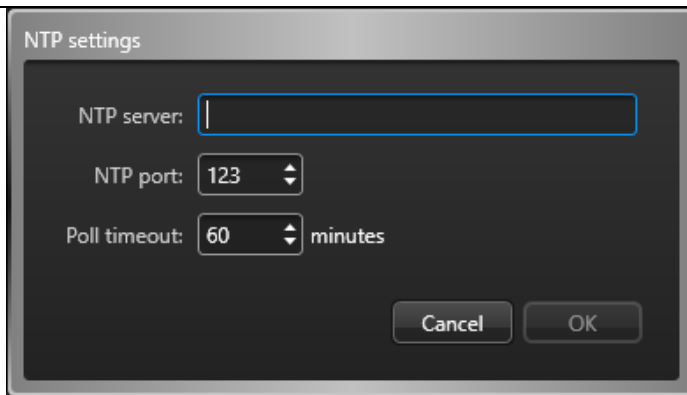

Config Tool → System → Roles → Archiver → Resources

Under Recording → Disk group, uncheck C:\ drive  
 Drives D:\ through G:\ should be checked  
 Min. free space should be changed to 4096 MB (4 GB) for drives D, E, F, G, click Apply  
 Click Advance settings

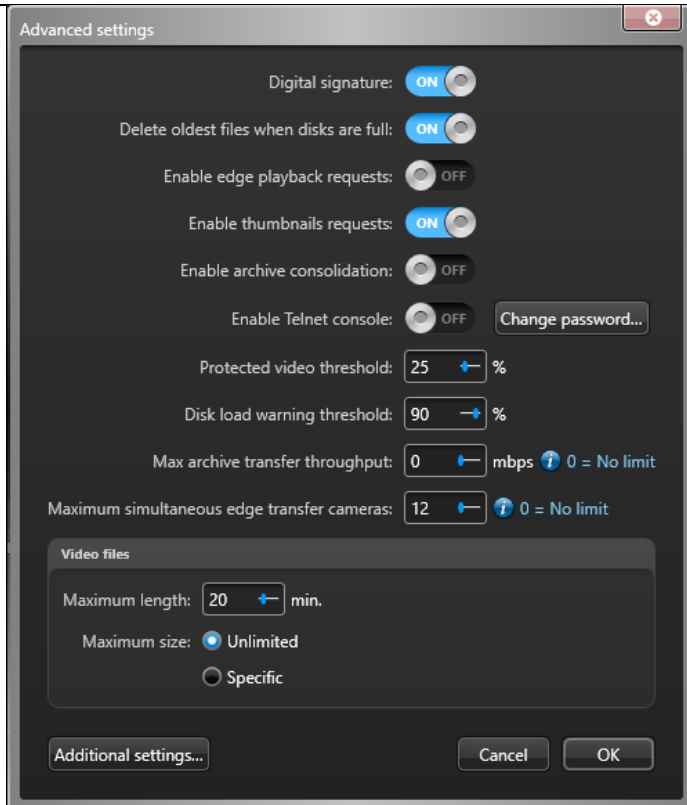

Digital signature: ON

Under Video files section, set Maximum size to: Unlimited

Make sure all settings match this screenshot

Click OK, Apply

**Security Center Core installation is complete.**

**Proceed below to configuring cameras and customization.**

**Below instructions are to be done after install.**

Config Tool → Tools → Unit enrollment

Option 1: Start discovery, wait for cameras to populate in box and choose add all

Option 2: Click Manual add → Video

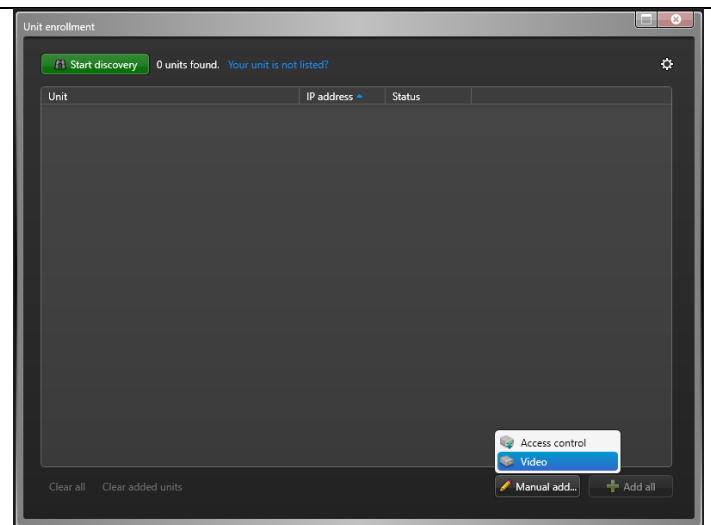
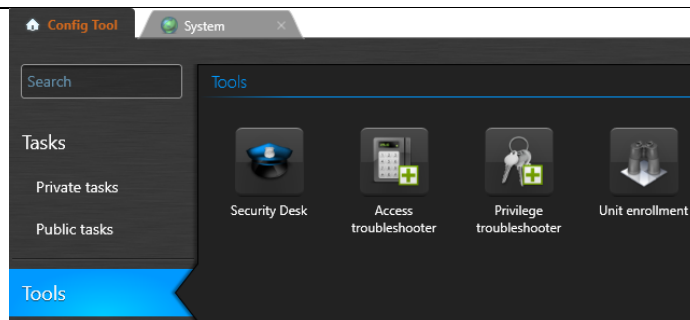

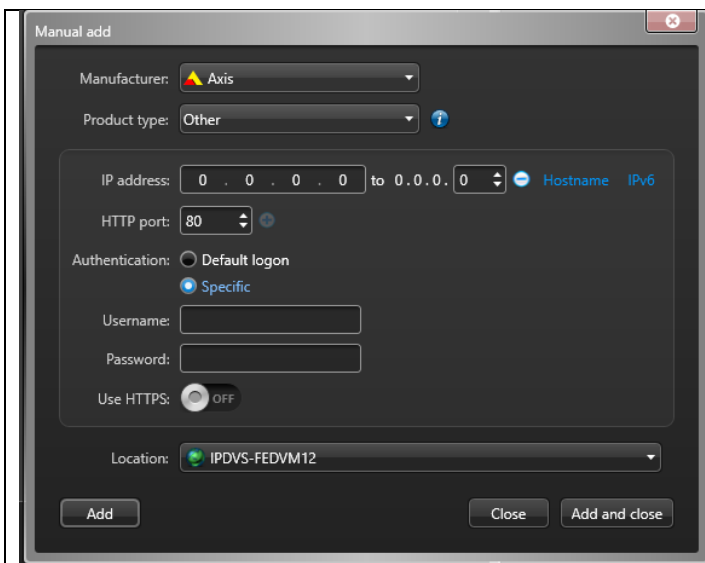

Pick Camera Manufacturer

Product type: choose type depending on camera manufacturer

IP address: Range of IP cameras or Analog VPUs

Authentication: specific

Populate username and password of cameras or VPUs

Select: add and close

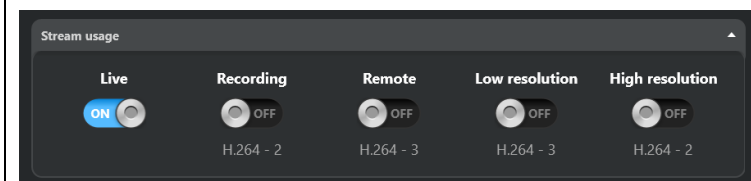
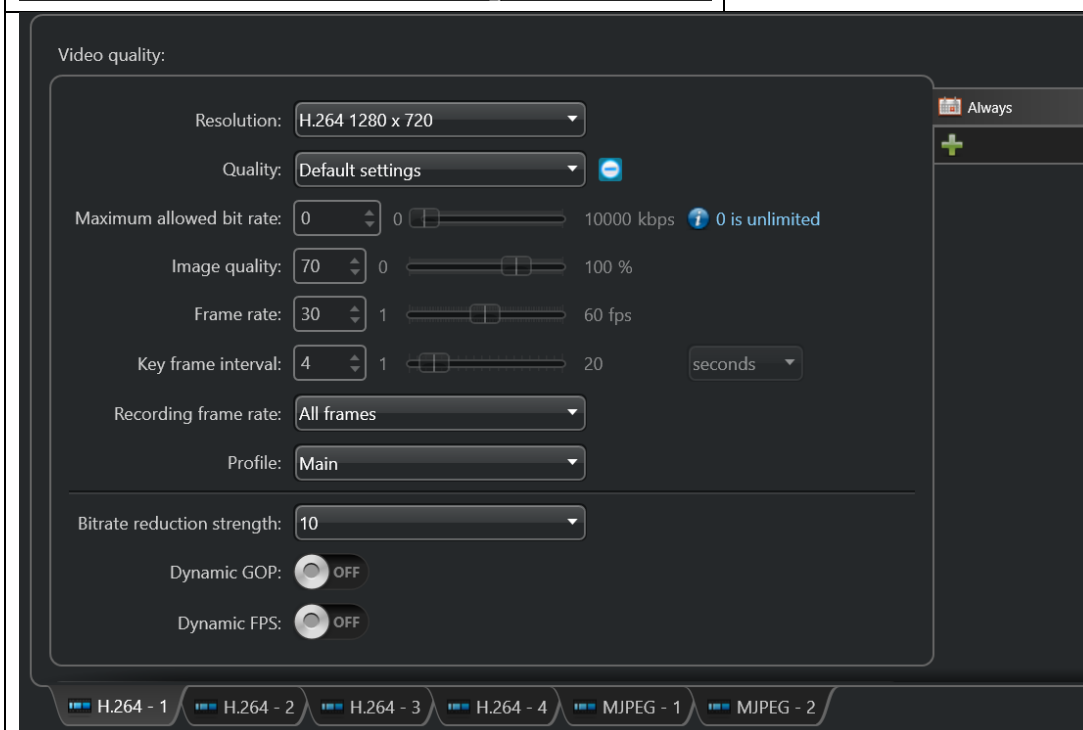

For each camera H.264.1 → Video quality settings should match the settings above (This is the live Stream)

Resolution: 1280 x 720

Quality: Default settings

Click Apply

Video quality:

Resolution: H.264 1280 x 720

Quality: Full motion (30 fps)

Maximum allowed bit rate: 0 0 10000 kbps 0 is unlimited

Image quality: 75 0 100 %

Frame rate: 30 1 60 fps

Key frame interval: 3 1 20 seconds

Recording frame rate: All frames

Profile: Main

Bitrate reduction strength: 10

Dynamic GOP: OFF

Dynamic FPS: OFF

H.264 - 1 H.264 - 2 H.264 - 3 H.264 - 4 MJPEG - 1 MJPEG - 2

Stream usage

Live OFF H.264 - 1

Recording ON H.264 - 2

Remote OFF H.264 - 3

Low resolution OFF H.264 - 4

High resolution ON H.264 - 3

For each camera H.264.2 → Video quality settings should match the settings above

Resolution: 1280 x 720

Quality: Full motion (30 fps)

Click Apply

Video quality:

Resolution: H.264 1280 x 720

Quality: High (15 fps)

Maximum allowed bit rate: 0 0 10000 kbps 0 is unlimited

Image quality: 40 0 100 %

Frame rate: 15 1 60 fps

Key frame interval: 4 1 20 seconds

Recording frame rate: All frames

Profile: Main

Bitrate reduction strength: 10

Dynamic GOP: OFF

Dynamic FPS: OFF

H.264 - 1 H.264 - 2 H.264 - 3 H.264 - 4 MJPEG - 1 MJPEG - 2

Stream usage

Live OFF H.264 - 1

Recording OFF H.264 - 2

Remote ON

Low resolution ON

High resolution OFF H.264 - 2

For each camera H.264.2 → Video quality settings should match the settings above

Resolution: 1280 x 720

Quality: Full motion (15 fps)

Click Apply

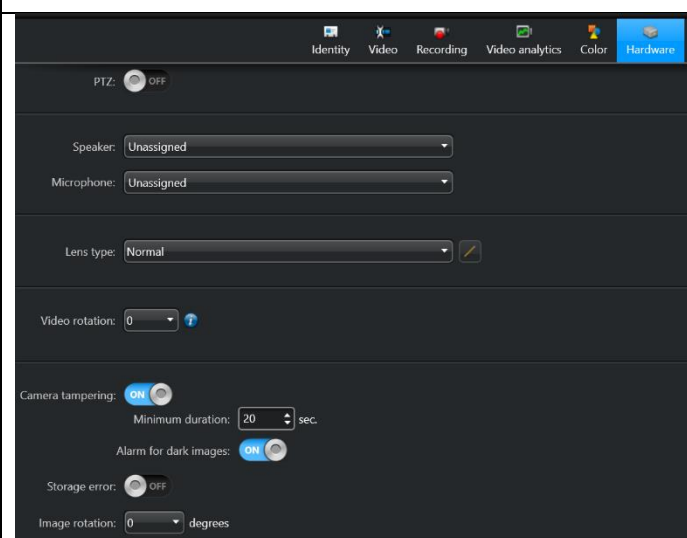
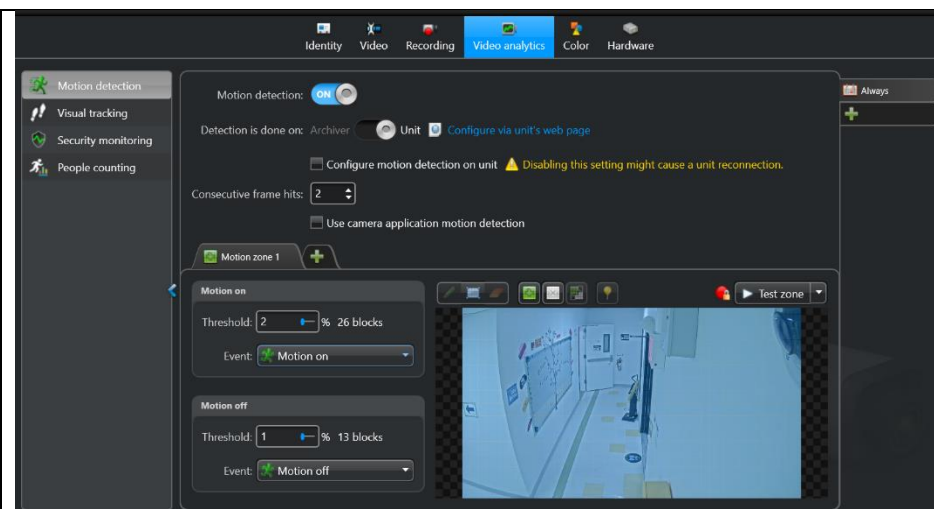

Video analytics → Motion detection

Motion detection: ON

Detection is done on: Unit

Uncheck: Configure motion detection on unit

Consecutive frame hits: 2

Uncheck: Use camera application motion detection

Under Motion zone 1 → Motion on

Threshold: 2% (26 blocks)

Event: Motion on

Under Motion zone 1 → Motion off

Threshold: 1% (13 blocks)

Event: Motion off

Hardware:

Speaker: Unassigned  
Microphone: Unassigned  
All other settings as shown

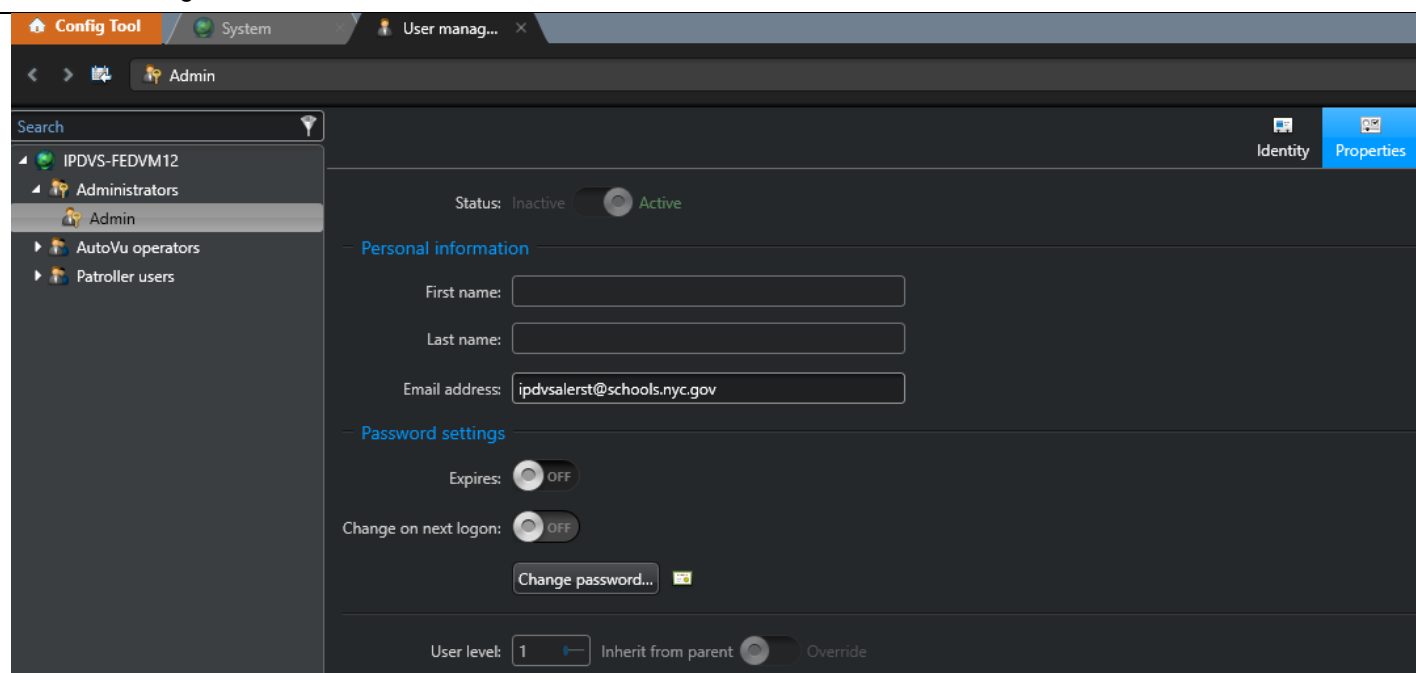

Config tool → Tasks → User management  
Choose the Admin account then choose properties  
Set email address to: [ipdvsalerst@schools.nyc.gov](mailto:ipdvsalerst@schools.nyc.gov)  
Click Apply

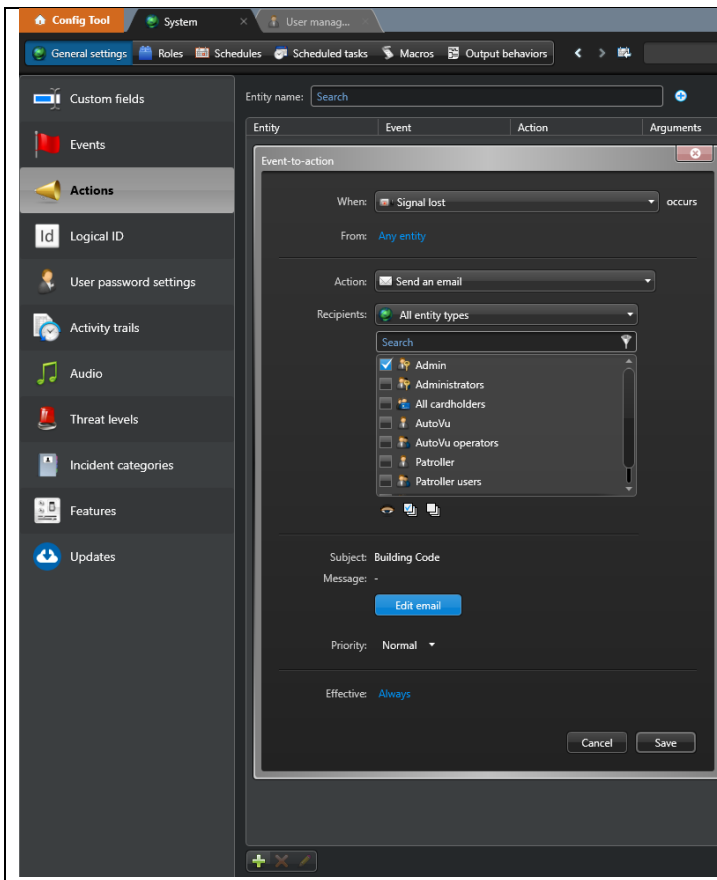

Config tool → System → General settings → Actions

Click the plus (+) icon, a pop-up will appear

When: Signal lost

From: Any entity

Action: Send an email

Under Recipients: only check Admin

Edit email, set Subject: to building code

Save, apply

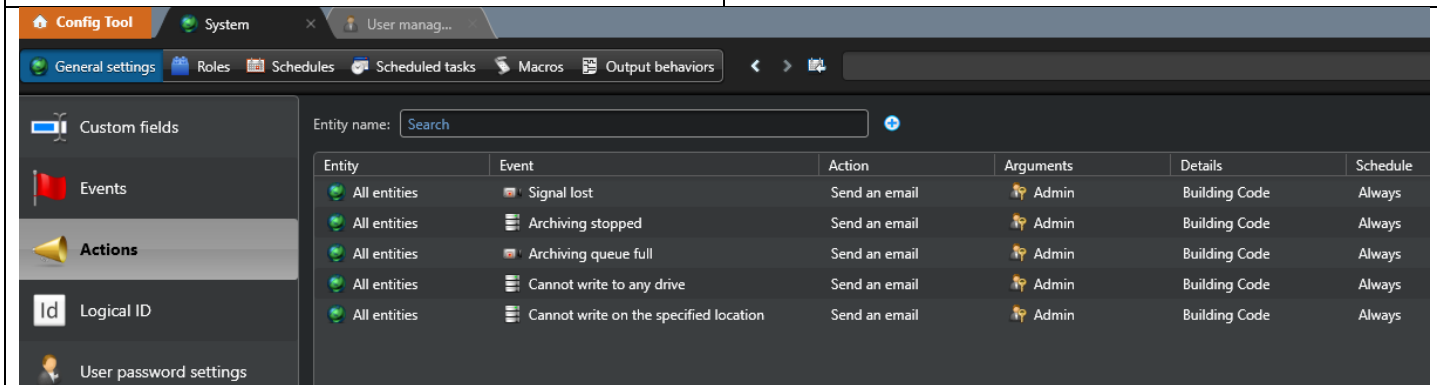

Repeat above steps by clicking Plus (+) icon and adding:

Archiving stopped

Archiving queue full

Cannot write to any drive

Cannot write on the specified location

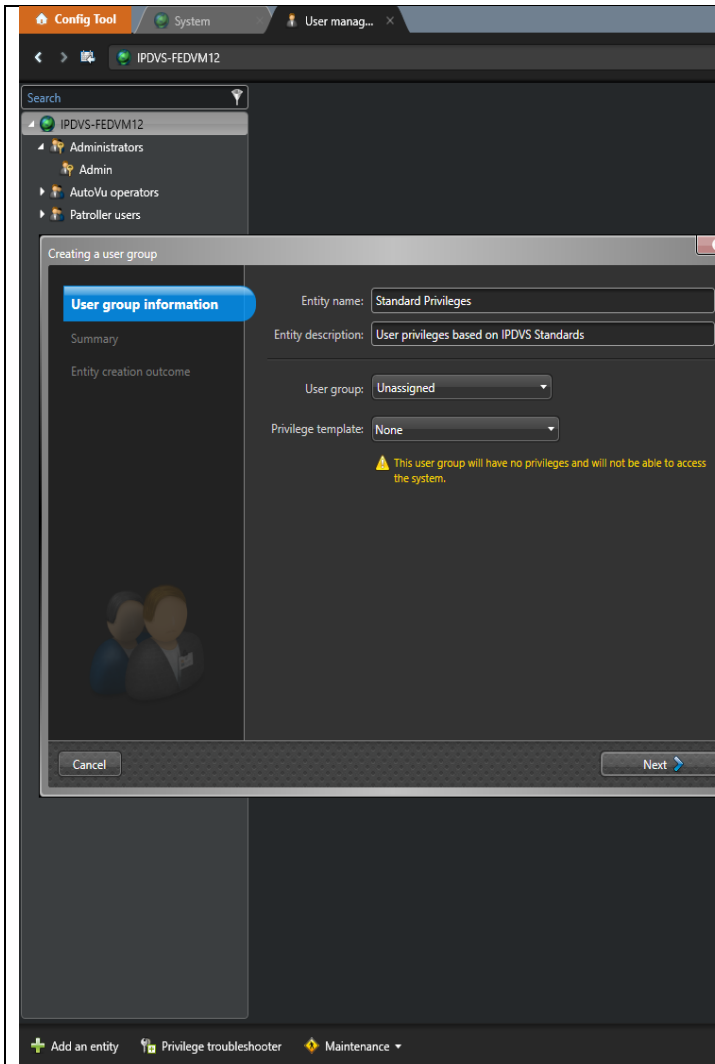

Config Tool → User Management → click (+) Add an Entity → User group, a pop-up will appear

Entity name: Standard Privileges

Entity description: User privileges based on IPDVS Standards

User group: Unassigned

Privilege template: None

Click Next

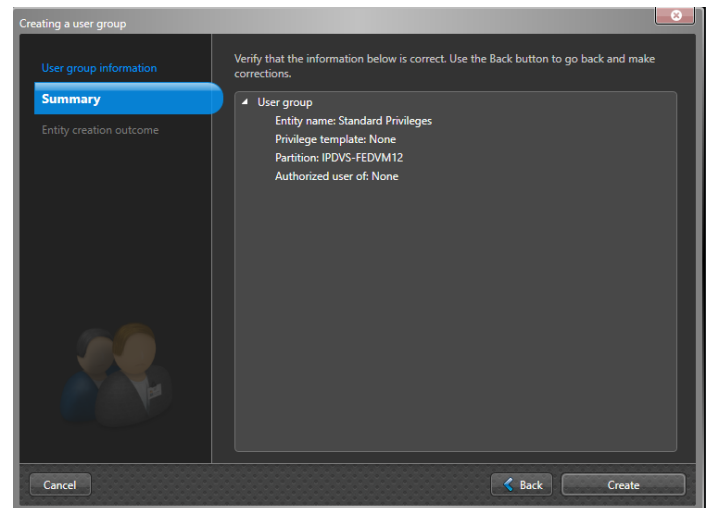

Double check Information

Click Create, click Close

Below is the process to creating user account in Security Center 5.9

For any questions or concerns, please contact IPDVS Deployment at 718-935-4800.

1. In Security Center 5.9. Config Tool, go to Tasks -> User Management
2. Create the "Standard IPDVS Privileges" group  
(right click on the left pane, click Add an Entity -> User Group)
  - a. Name: **Standard IPDVS Privileges**
  - b. Description: **Privileges based on IPDVS Standards**
  - c. User Group: **Unassigned**
  - d. Privilege Template: **None**
3. Configure privileges for the "Standard IPDVS Privileges" group
  - a. Please follow the settings based on the screenshots below.
  - b. *Note:* One way to simplify the process is to first deny all privileges. Then go through each privilege setting and adjust them to allow or deny as needed.

#### 4. Create User Accounts

(right click on the Standard IPDVS Privileges group, click Add an Entity -> User)

- a. Username: same as the person's DOE username (email address)
  - i. Exception: School Safety Agents: their username is always SSABASE
    1. If there are multiple computers for the school safety agent, each of their computer will get an account. Add a number to the end of the user name. For Example: SSABASE, SSABASE2, SSABASE3
- b. Password: **changeme1**
- c. First Name – Enter user's first name
- d. Last Name – Enter user's last name
- e. User Group: **Standard IPDVS Privileges**
- f. Privilege Template: **None**

#### 5. For each account you create, go into each account and do the following:

For steps B, C, and D, you do can do this once and "copy configuration" to the other users.

- a. Identity tab
  - i. Add description – List the person's title and school code
- b. Properties tab
  - i. First Name – Should already be there from previous step/Enter user's first name
  - ii. Last Name – Should already be there from previous step / Enter user's last name
  - iii. Email – Enter user's email address
  - iv. Password Expires: **Off**
  - v. Change on next logon: **Off**
- c. Privileges tab – Do not change. It will inherit from the group's privileges
  - i. *Exception: User needs additional restrictions (ie: no PTZ controls)*
  - ii. If users need additional rights, a new special group will need to be created for said users. Please notify IPDVS Deployment (718-935-4800) prior to doing this.
- d. Advance tab
  - i. Set *Limit concurrent logins* to "**On**" and

Set *Limit concurrent logins* to "**1**" workstation

Privileges	Allow	Deny	Undefine	Inherited from
▶ All privileges	<input type="radio"/>	<input type="radio"/>	<input type="radio"/>	
▶ Application privileges	<input type="radio"/>	<input type="radio"/>	<input type="radio"/>	
▶ Config Tool	<input type="radio"/>	<input type="radio"/>	<input type="radio"/>	
▶ Security Desk	<input checked="" type="radio"/>	<input type="radio"/>	<input type="radio"/>	
Change client views	<input checked="" type="radio"/>	<input type="radio"/>	<input type="radio"/>	
Change Security Desk options	<input checked="" type="radio"/>	<input type="radio"/>	<input type="radio"/>	
Change tile content	<input checked="" type="radio"/>	<input type="radio"/>	<input type="radio"/>	
▶ Change tile pattern	<input checked="" type="radio"/>	<input type="radio"/>	<input type="radio"/>	
Edit tile patterns	<input checked="" type="radio"/>	<input type="radio"/>	<input type="radio"/>	
Change workspace	<input checked="" type="radio"/>	<input type="radio"/>	<input type="radio"/>	
Start/stop task cycling	<input checked="" type="radio"/>	<input type="radio"/>	<input type="radio"/>	
Web Client	<input type="radio"/>	<input checked="" type="radio"/>	<input type="radio"/>	
SDK Log on using the SDK	<input type="radio"/>	<input checked="" type="radio"/>	<input type="radio"/>	
Global Cardholder Synchronizer	<input type="radio"/>	<input checked="" type="radio"/>	<input type="radio"/>	
Mobile application	<input type="radio"/>	<input checked="" type="radio"/>	<input type="radio"/>	
Federation™	<input type="radio"/>	<input checked="" type="radio"/>	<input type="radio"/>	
▶ Patroller	<input type="radio"/>	<input checked="" type="radio"/>	<input type="radio"/>	
Access reads/hits from an LPR Mana	<input type="radio"/>	<input checked="" type="radio"/>	<input type="radio"/>	
General privileges	<input type="radio"/>	<input type="radio"/>	<input type="radio"/>	
View web pages	<input type="radio"/>	<input checked="" type="radio"/>	<input type="radio"/>	
Change own password	<input checked="" type="radio"/>	<input type="radio"/>	<input type="radio"/>	
Print/export reports	<input type="radio"/>	<input checked="" type="radio"/>	<input type="radio"/>	
Remove entries from a report	<input checked="" type="radio"/>	<input type="radio"/>	<input type="radio"/>	
▶ Report incidents	<input type="radio"/>	<input checked="" type="radio"/>	<input type="radio"/>	
Modify reported incidents	<input type="radio"/>	<input checked="" type="radio"/>	<input type="radio"/>	
Delete reported incidents	<input type="radio"/>	<input checked="" type="radio"/>	<input type="radio"/>	
View license	<input type="radio"/>	<input checked="" type="radio"/>	<input type="radio"/>	
View charts	<input type="radio"/>	<input checked="" type="radio"/>	<input type="radio"/>	
Switch to map mode	<input type="radio"/>	<input checked="" type="radio"/>	<input type="radio"/>	License
▶ Administrative privileges	<input type="radio"/>	<input checked="" type="radio"/>	<input type="radio"/>	

Privileges	Allow	Deny	Undefine	Inherited from
▶ Administrative privileges	<input type="radio"/>	<input checked="" type="radio"/>	<input type="radio"/>	
▶ Task privileges	<input type="radio"/>	<input type="radio"/>	<input type="radio"/>	
▶ Manage private tasks	<input checked="" type="radio"/>	<input type="radio"/>	<input type="radio"/>	
▶ View public tasks	<input checked="" type="radio"/>	<input type="radio"/>	<input type="radio"/>	
▶ Modify public tasks	<input type="radio"/>	<input checked="" type="radio"/>	<input type="radio"/>	
Add public tasks	<input type="radio"/>	<input checked="" type="radio"/>	<input type="radio"/>	
Delete public tasks	<input checked="" type="radio"/>	<input type="radio"/>	<input type="radio"/>	
▶ Administration	<input type="radio"/>	<input checked="" type="radio"/>	<input type="radio"/>	
▶ Operation	<input type="radio"/>	<input type="radio"/>	<input type="radio"/>	
▶ Monitoring	<input checked="" type="radio"/>	<input type="radio"/>	<input type="radio"/>	
▶ View dashboards	<input type="radio"/>	<input checked="" type="radio"/>	<input type="radio"/>	
Modify dashboards	<input type="radio"/>	<input checked="" type="radio"/>	<input type="radio"/>	
View security widget	<input type="radio"/>	<input checked="" type="radio"/>	<input type="radio"/>	
Cardholder management	<input type="radio"/>	<input checked="" type="radio"/>	<input type="radio"/>	
▶ Visitor management	<input type="radio"/>	<input checked="" type="radio"/>	<input type="radio"/>	
People counting	<input type="radio"/>	<input checked="" type="radio"/>	<input type="radio"/>	
Credential management	<input type="radio"/>	<input checked="" type="radio"/>	<input type="radio"/>	
Inventory management	<input type="radio"/>	<input checked="" type="radio"/>	<input type="radio"/>	
Hotlist and permit editor	<input type="radio"/>	<input checked="" type="radio"/>	<input type="radio"/>	
▶ Remote	<input type="radio"/>	<input checked="" type="radio"/>	<input type="radio"/>	
Spy mode	<input type="radio"/>	<input checked="" type="radio"/>	<input type="radio"/>	
▶ Maps	<input type="radio"/>	<input type="radio"/>	<input type="radio"/>	
Modify layers	<input type="radio"/>	<input checked="" type="radio"/>	<input type="radio"/>	
View mobile users	<input type="radio"/>	<input checked="" type="radio"/>	<input type="radio"/>	
Mustering	<input type="radio"/>	<input checked="" type="radio"/>	<input type="radio"/>	
▶ Investigation	<input type="radio"/>	<input type="radio"/>	<input type="radio"/>	
▶ Access control	<input type="radio"/>	<input checked="" type="radio"/>	<input type="radio"/>	
▶ Asset management	<input type="radio"/>	<input type="radio"/>	<input type="radio"/>	
▶ LPR	<input type="radio"/>	<input checked="" type="radio"/>	<input type="radio"/>	
▶ Video	<input checked="" type="radio"/>	<input type="radio"/>	<input type="radio"/>	
Security video analytics report	<input checked="" type="radio"/>	<input type="radio"/>	<input type="radio"/>	
Archives	<input type="radio"/>	<input type="radio"/>	<input type="radio"/>	
Bookmarks	<input checked="" type="radio"/>	<input type="radio"/>	<input type="radio"/>	
Motion search	<input checked="" type="radio"/>	<input type="radio"/>	<input type="radio"/>	
Camera events	<input checked="" type="radio"/>	<input type="radio"/>	<input type="radio"/>	
Forensic search	<input type="radio"/>	<input type="radio"/>	<input type="radio"/>	
Incidents	<input checked="" type="radio"/>	<input type="radio"/>	<input type="radio"/>	
Zone activities	<input type="radio"/>	<input checked="" type="radio"/>	<input type="radio"/>	

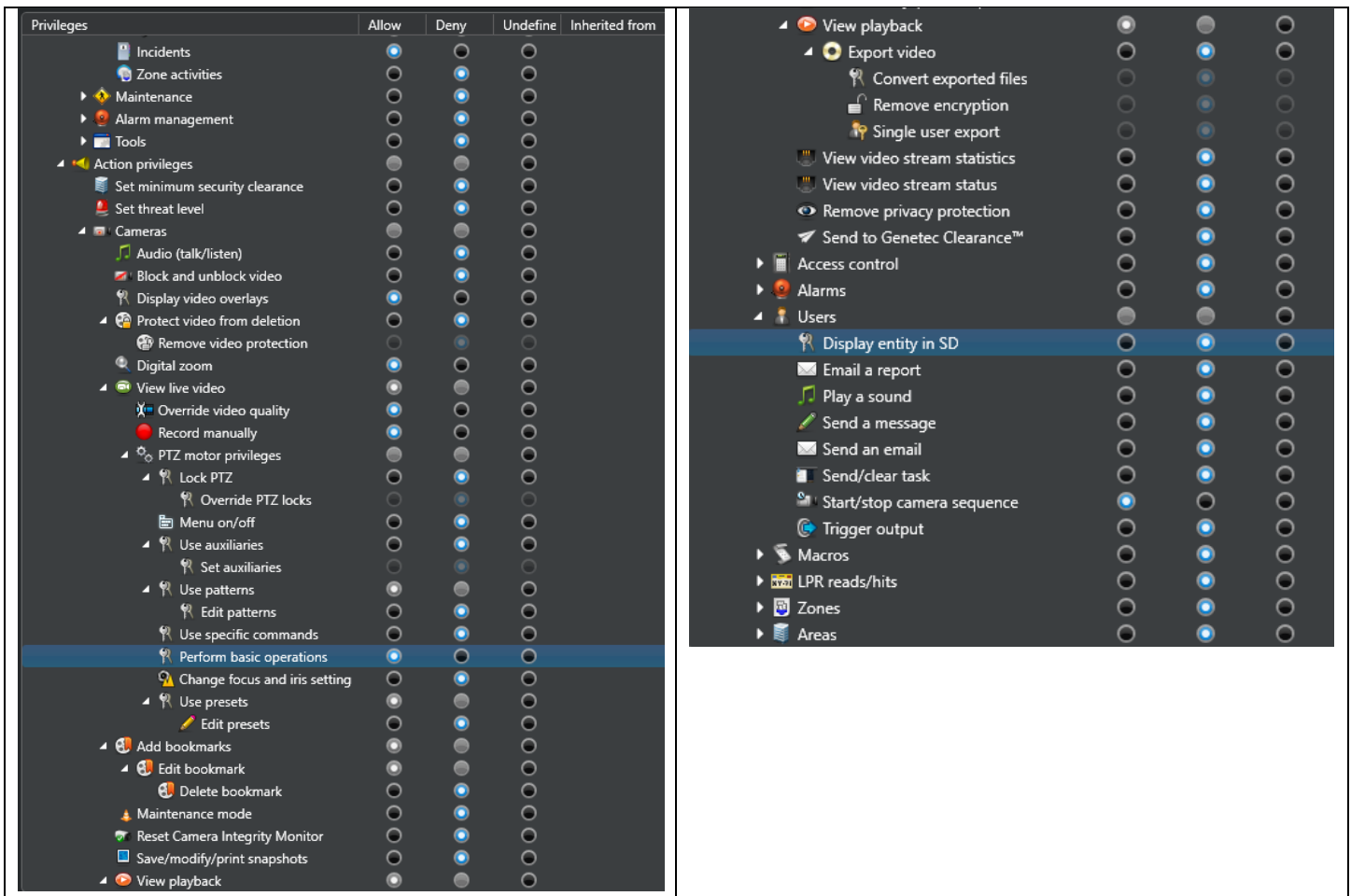

Click Apply

Privileges are complete at this point

Figure 4-99

1. Enter the pre-production password to login

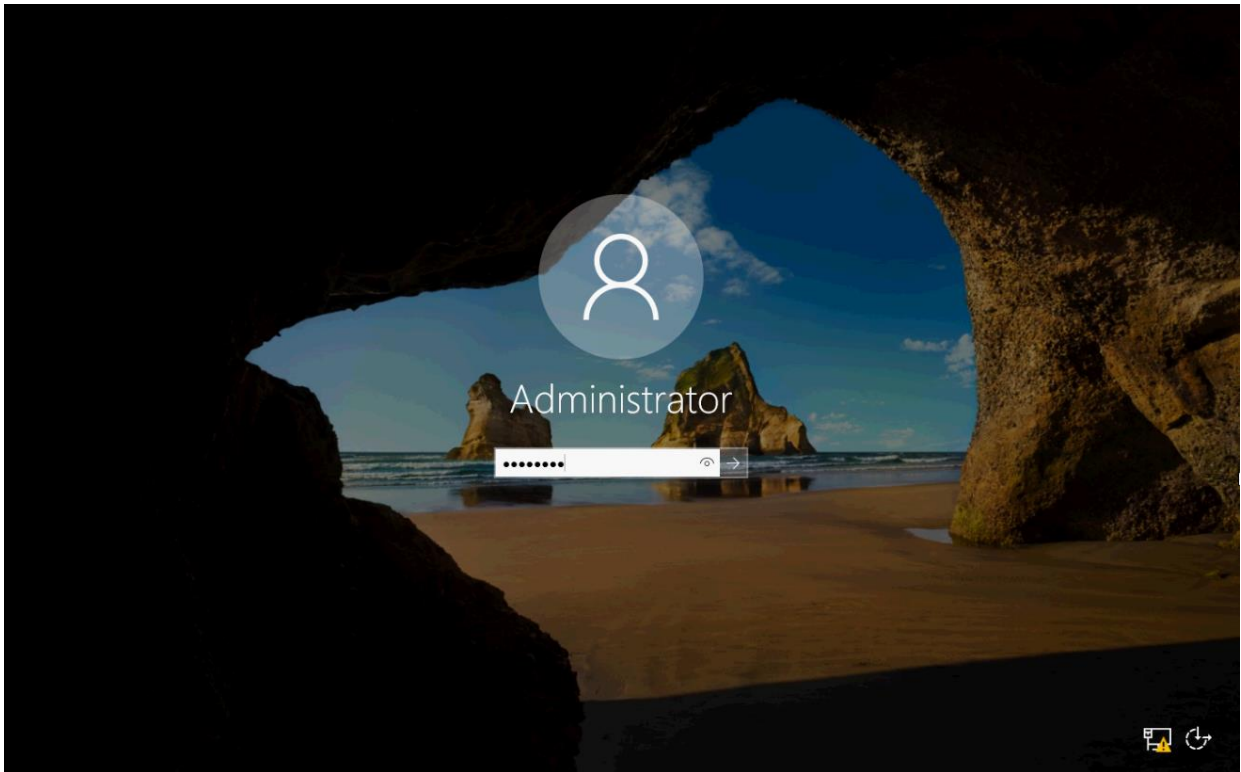

Figure 4-100

After installing Genetec Security Center run the below script when Server is on VLAN 470.  
 Located in C:\IPDVS Software\Scripts\2016\_PowerShell\_Script\2016\_PowerShell\_Script.ps1

 A screenshot of a Windows File Explorer window. The address bar shows the path: <code>C:\IPDVS SOFTWARE > Scripts > 2016\_Powershell\_Script</code>. The main pane displays a list of files and folders:
 

Name	Date modified	Type
BGInfo	1/10/2020 4:02 PM	File folder
LSA Script	1/10/2020 4:02 PM	File folder
OEM_Script	1/10/2020 4:02 PM	File folder
PowerShell_Scripts	1/10/2020 4:02 PM	File folder
2016_PowerShell_Script.ps1	1/10/2020 3:51 PM	Windows PowerS...

 The file "2016\_PowerShell\_Script.ps1" is selected, and a context menu is open over it with the following options: "Open", "Run with PowerShell", and "Edit".

Figure 4-101

2. Navigate to **C:\IPDVS SOFTWARE\Scripts\2016\_Powershell\_Script**

a. **Before running this script:**

- i. **Only run the script when the server is connected to the switch.**
- ii. This script is going to guide you and automate some of the server setup. After the script runs successfully, please validate if all the settings are correct.
- iii. In rare cases the script may fail on the first run, please just run it a second time.

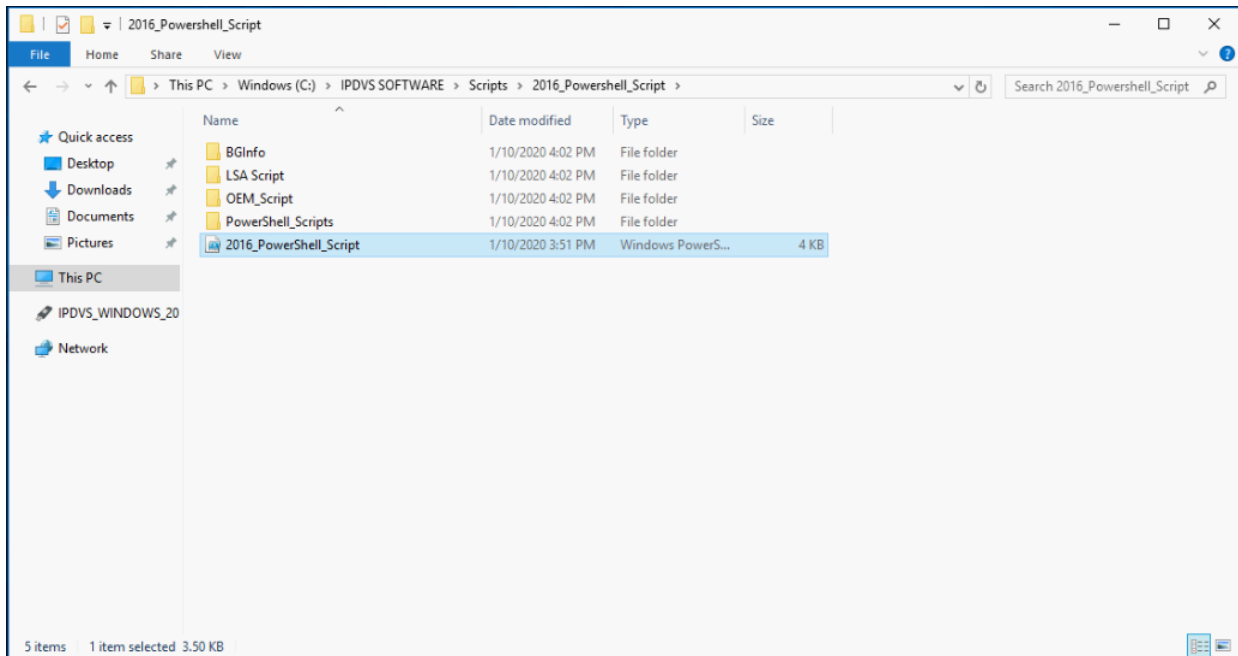

Figure 4-102

3. Right-Click **2016\_PowerShell\_Script** and click **run with PowerShell**.

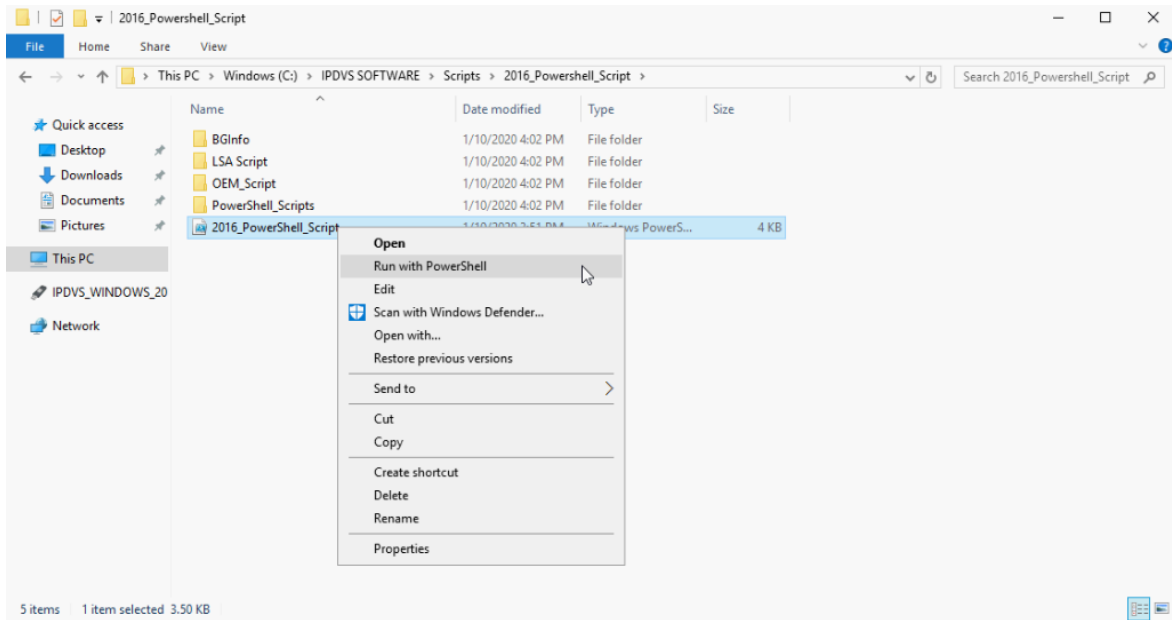

Figure 4-103

4. Type **L** (No to All) and press enter

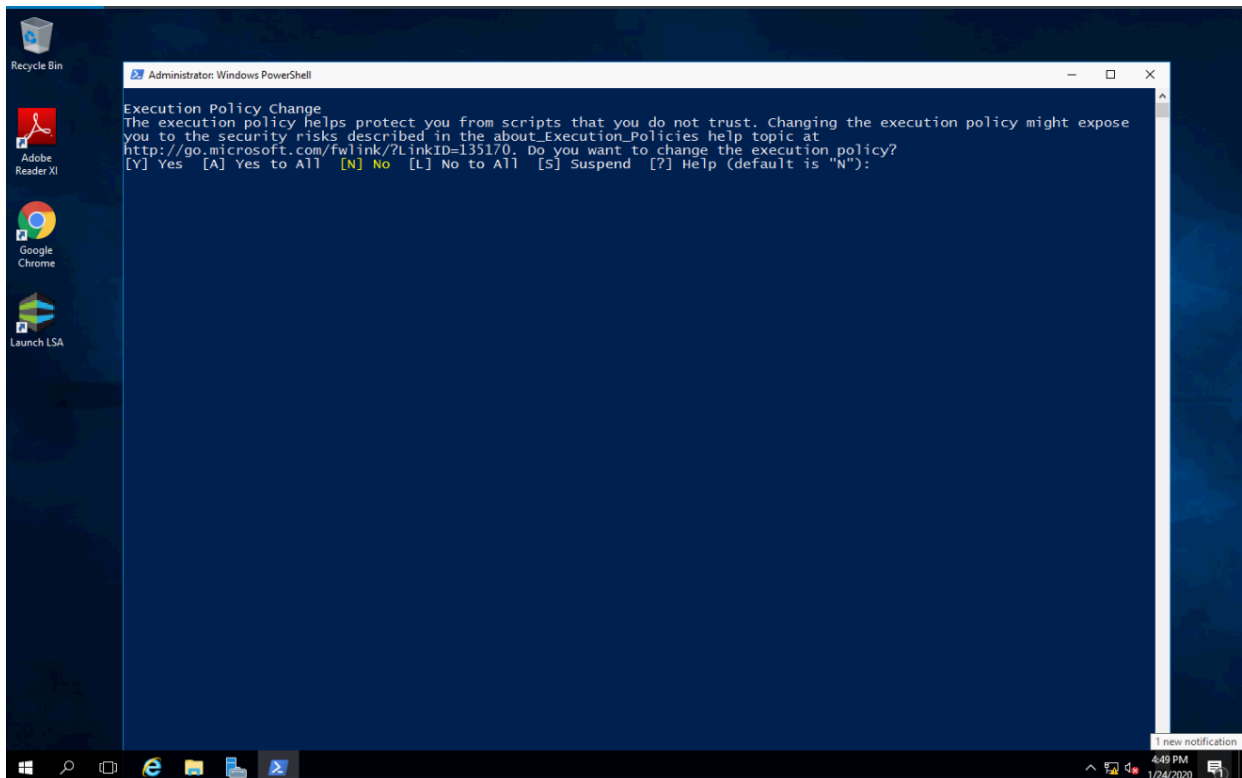

Figure 4-104

5. Next it will ask if this is the first time setting up Windows. **(Read Entirely, and Carefully Before Proceeding)**

If you choose **Y** for yes, the script will guide you in setting the NIC card and Computer Name.  
If you choose **N** for no, the script will skip the configuration of the NIC and Computer Name.  
If you already configured the NIC card and the Computer Name, then choose **N** for no.

*For this guide, we will choose N.*

*If you choose Y, then please follow the on screen instructions on configuring the Computer Name and NIC Card.*

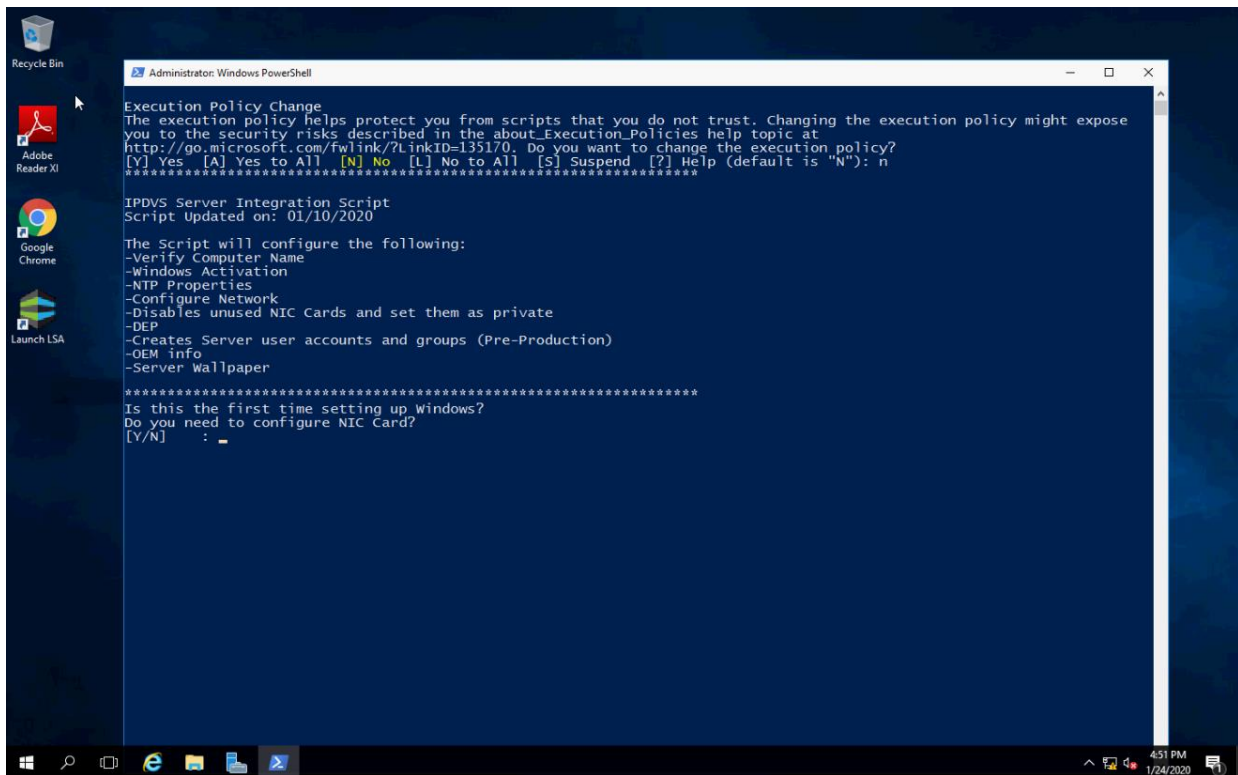

Figure 4-105

6. After choosing N the screen will tell you to Press Enter to continue. Press the Enter or Return key on the keyboard to continue.  
The script will do its tasks on disabling DEP, Firewall, Disable unused NICs and other tasks.

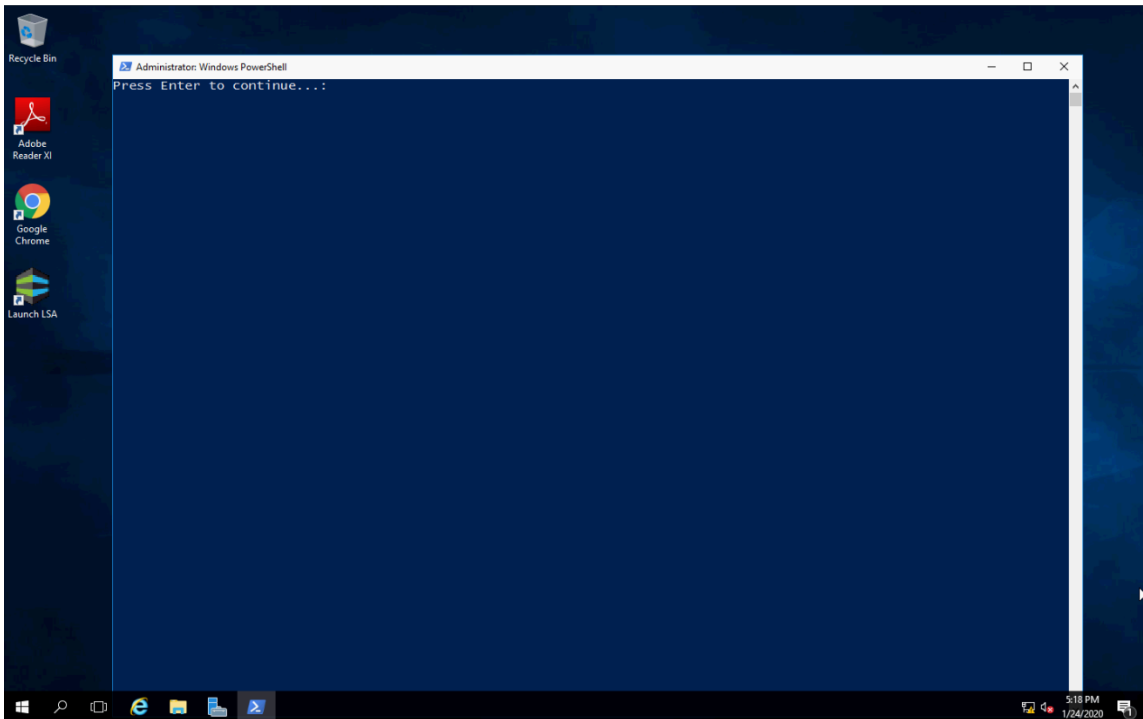

Figure 4-106

7. At the end of the script, it will tell the user to Restart the server. At this point, please restart the server.

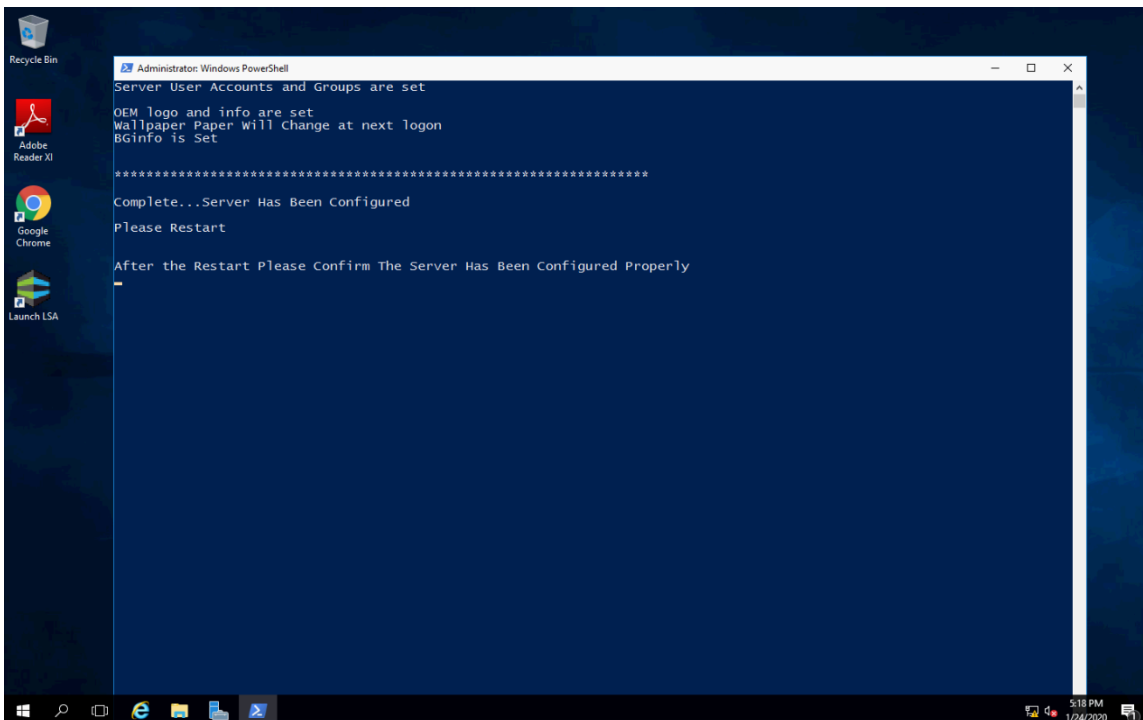

Figure 4-107

8. Restart the server so that all configurations could take effect.

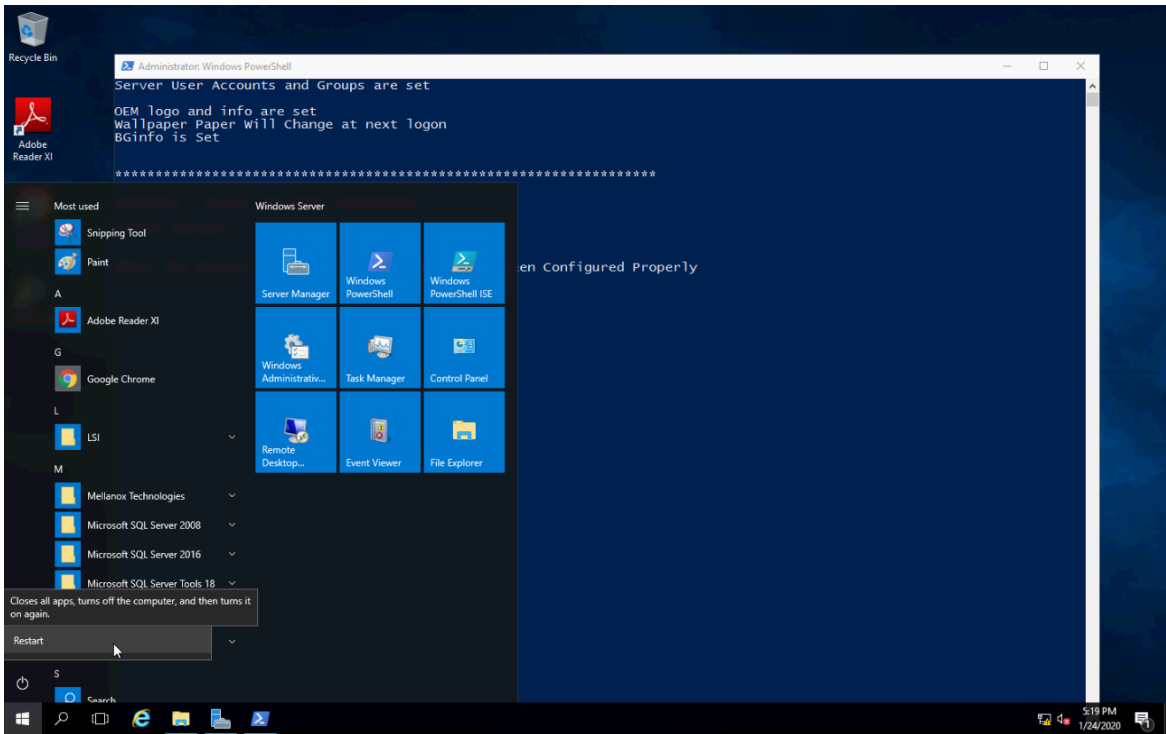

Figure 4-108

9. Type **Administrator** for the username, the password is the **pre-production** password

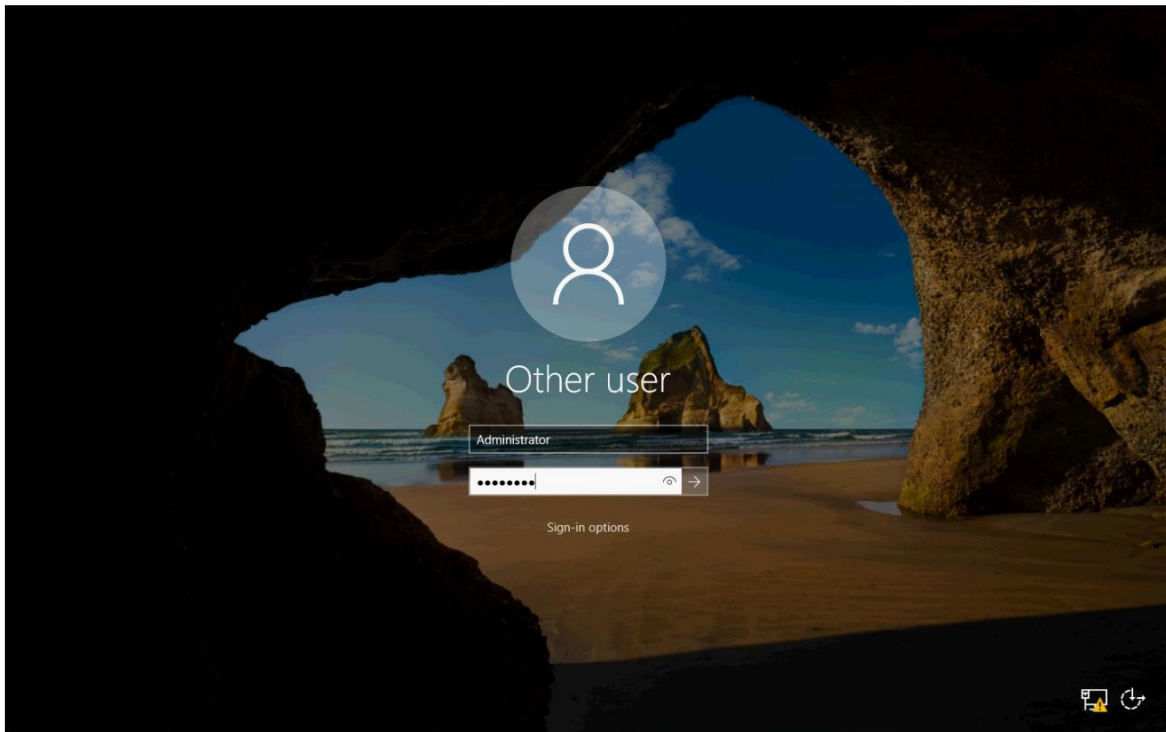

Figure 4-109

## Confirming the Server Settings

Now we will check and confirm that the script worked properly and all the settings are correct. If they are not, please correct the setting at this time.

10. If the script was successful, after logging in, the wallpaper will change to a grey color and display the server information along with the IPDVS logo.
11. The **Launch LSA** logo should also be in the Desktop icons, if not check if it's installed. If it's not installed please install it.

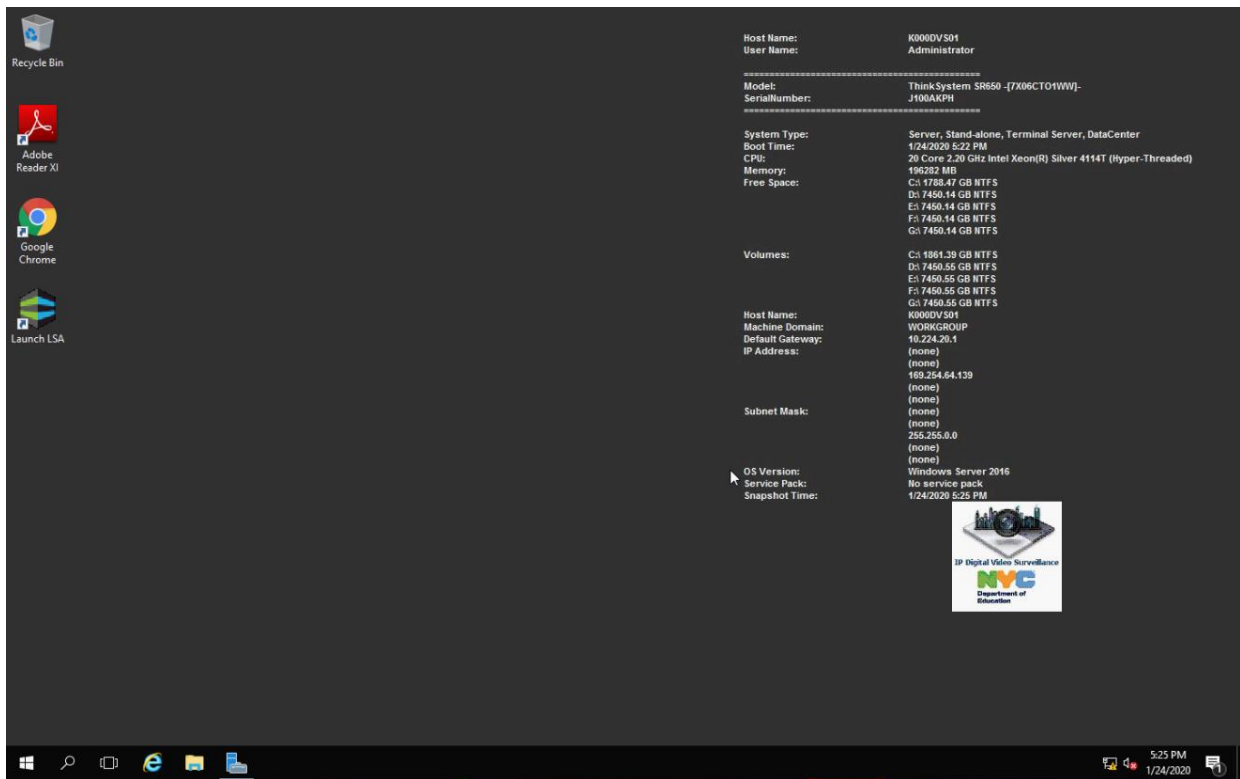

Figure 4-110

12. Right click the windows icon and select **System**

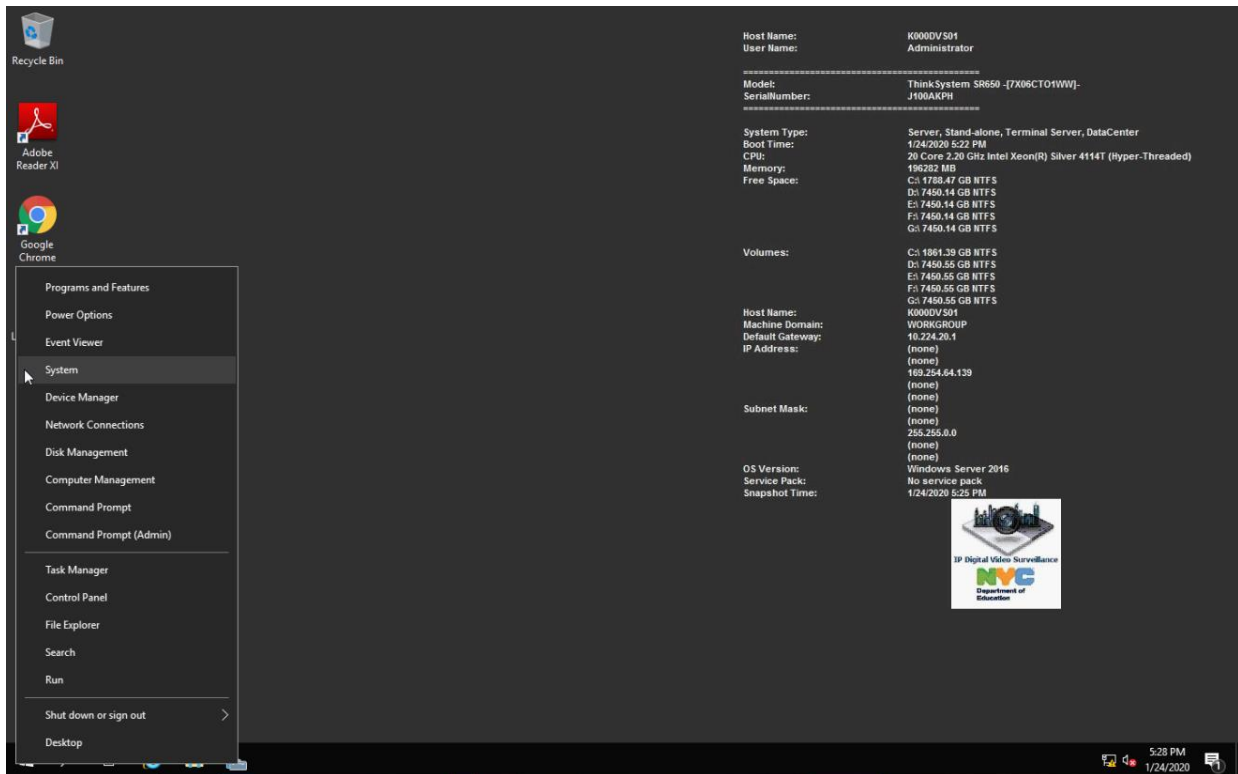

Figure 4-111

13. Verify the computer is named according to IPDVS Standards. The computer name should be **Building ID** followed by **DVS01**
14. Verify the NYCDOE/IPDVS support information is listed along with the NYCDOE/IPDVS icons
15. **Verify** Windows is activated.

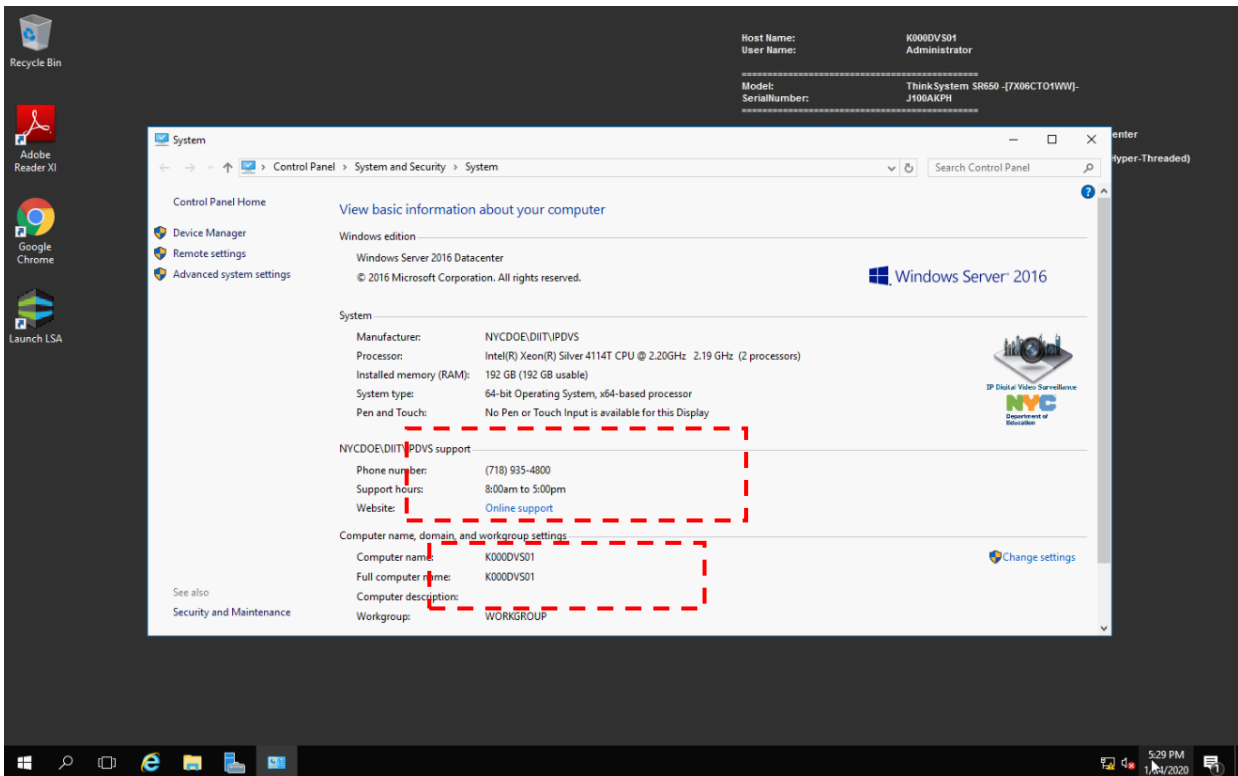

Figure 4-112

16. On the left side of the **System** window, click on **Advanced System Settings**.

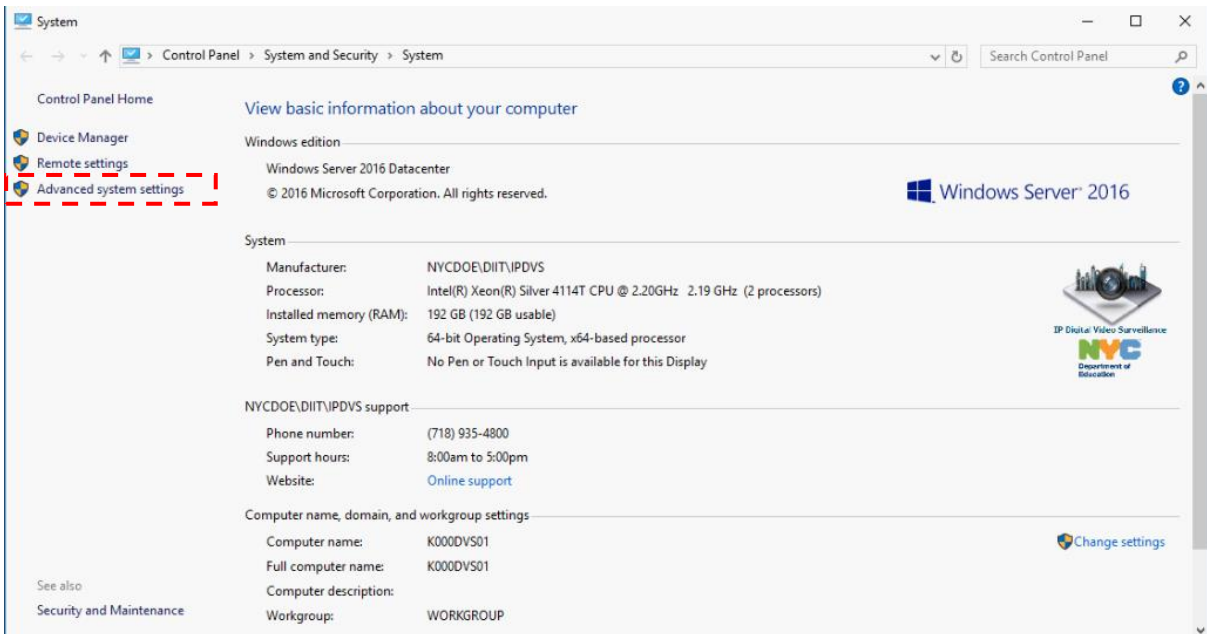

Figure 4-113

17. The **System Properties** window should open and already be set to the **Advanced** tab. In the **Performance** area, click on **Settings**.

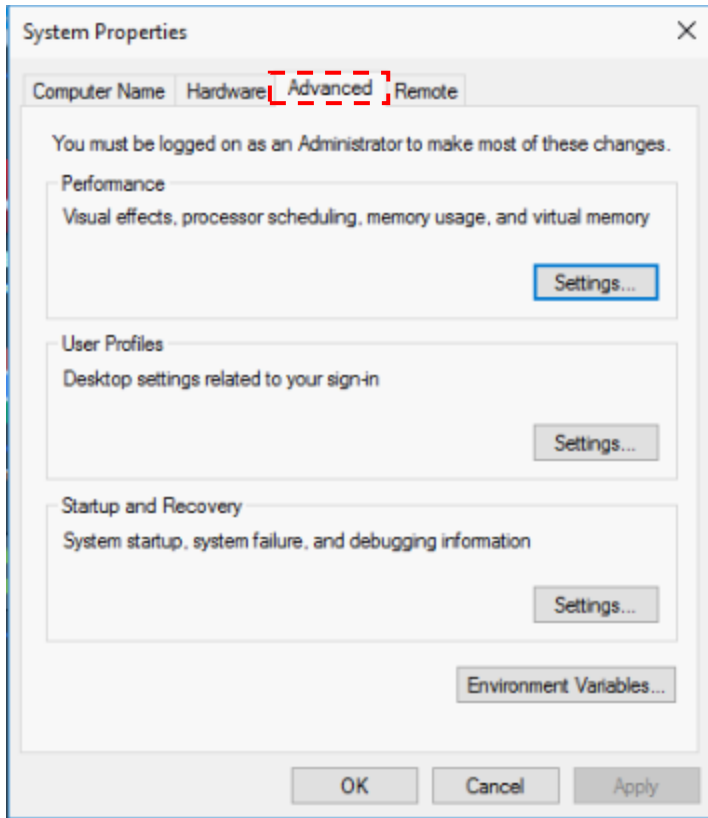

Figure 4-114

18. In the **Performance Options** window, click on the **Data Execution Prevention** tab.

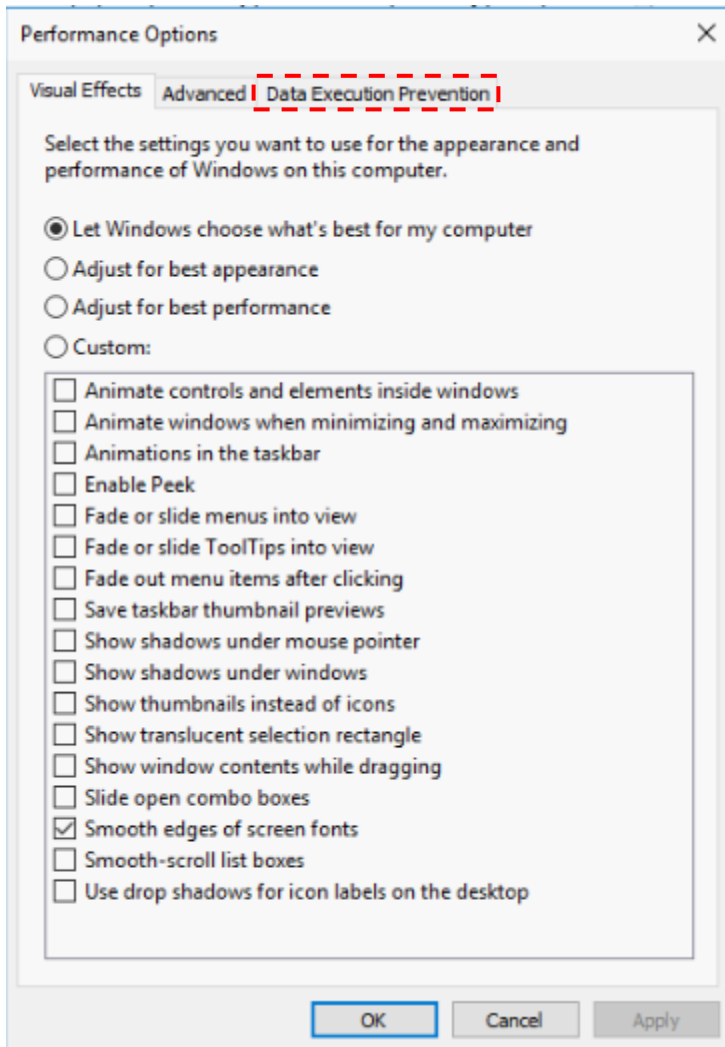

Figure 4-115

19. Make sure that **Turn on DEP for all programs except those that I select** is selected

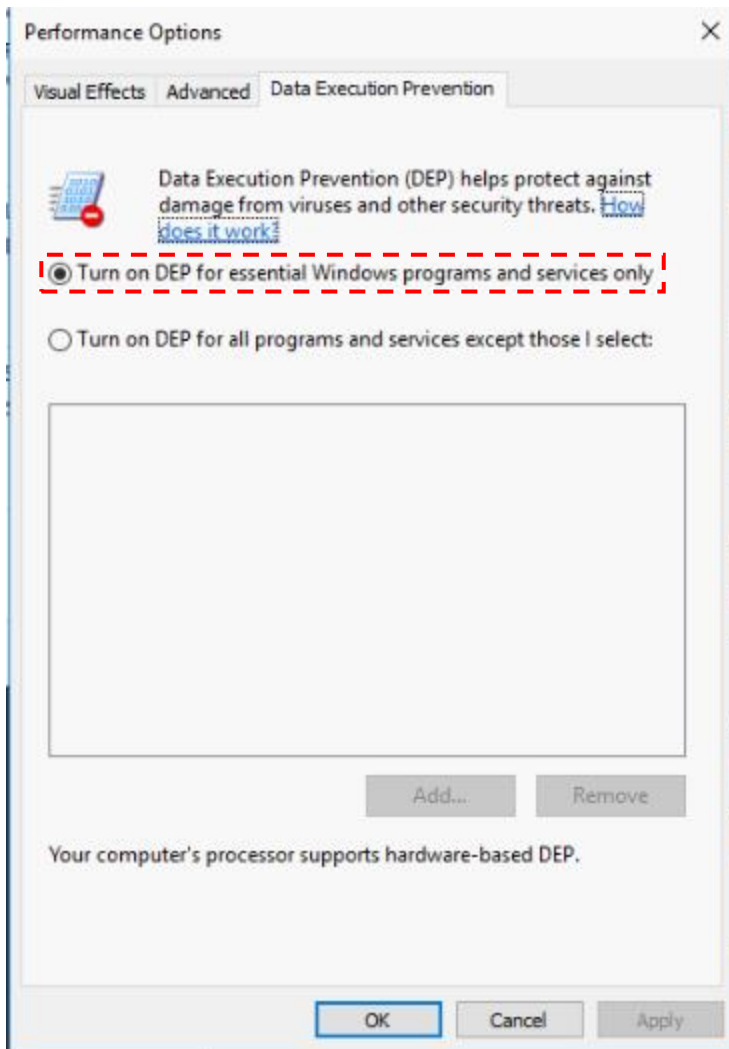

Figure 4-116

20. Confirm that SQL server 2016, SQL server management studio 18 is installed if the option was chosen

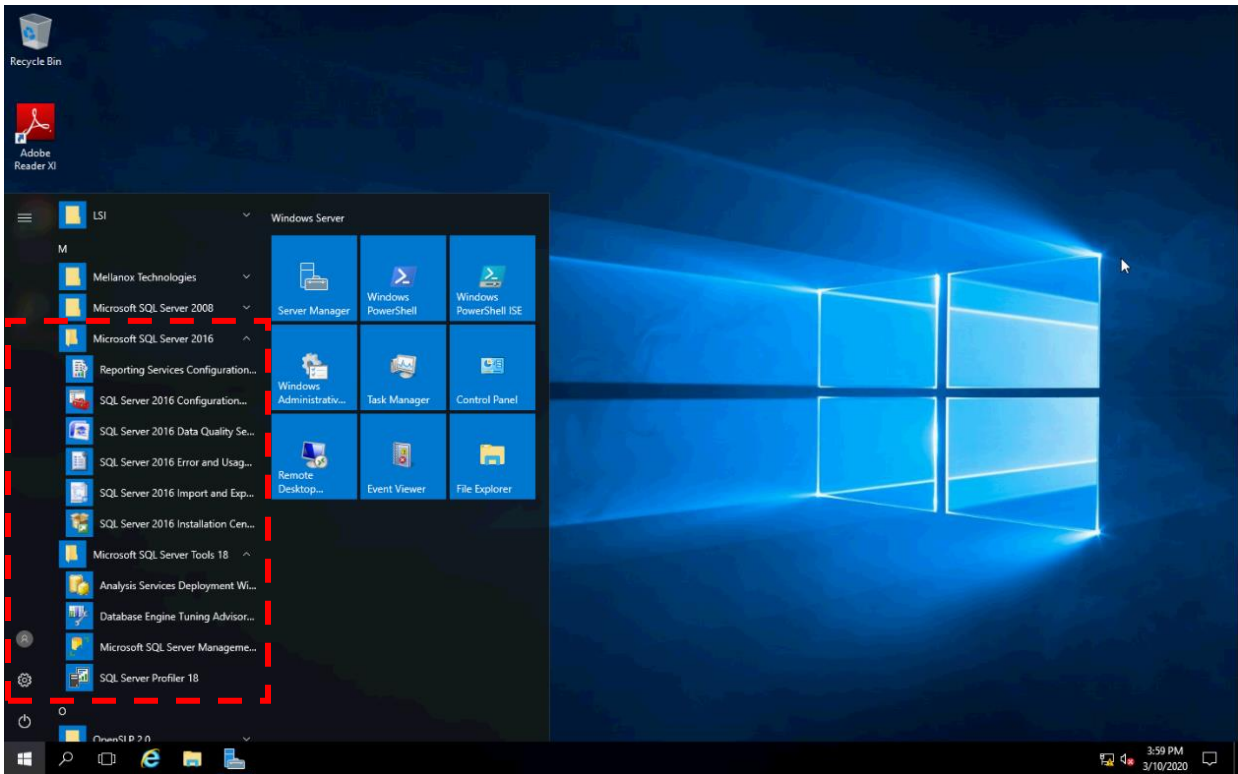

Figure 4-117

21. Make sure all unused NIC cards are disabled -- except for the active NIC card.
  - b. NOTE: Screenshot below is only a reference example. It may look different on your actual server.

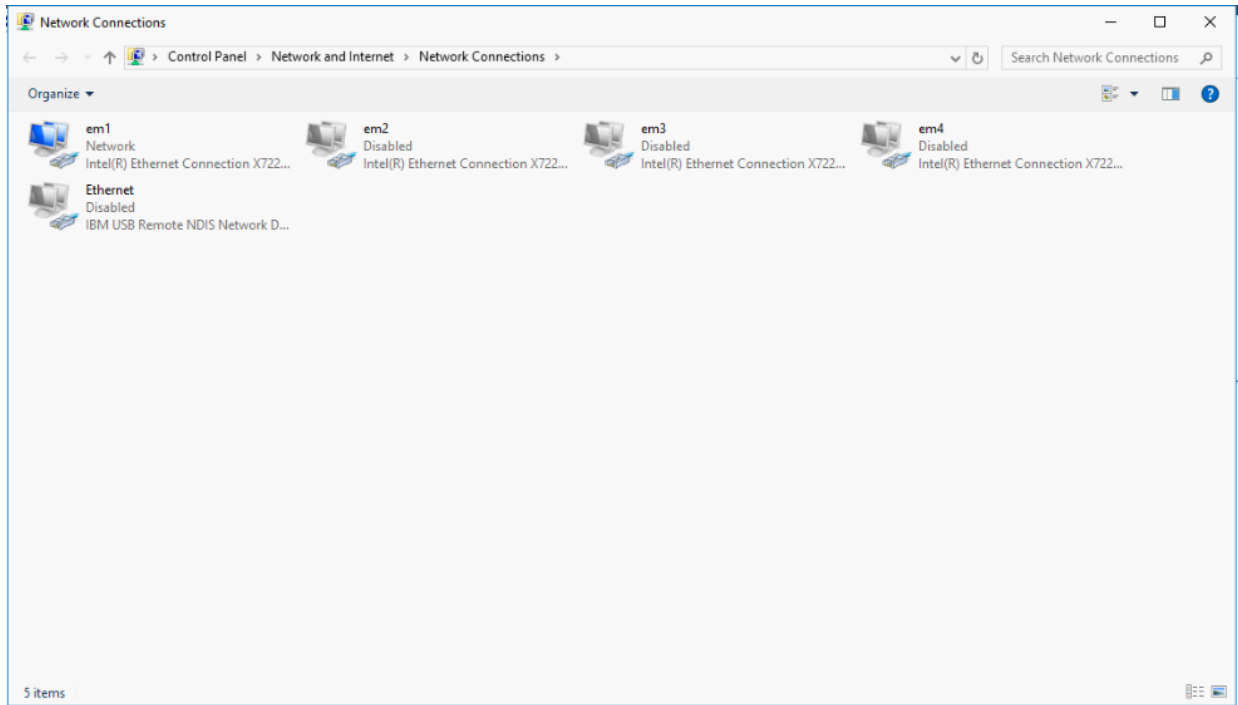

Figure 4-118

22. For the active NIC, **Right click** on the active NIC and select **Properties**.

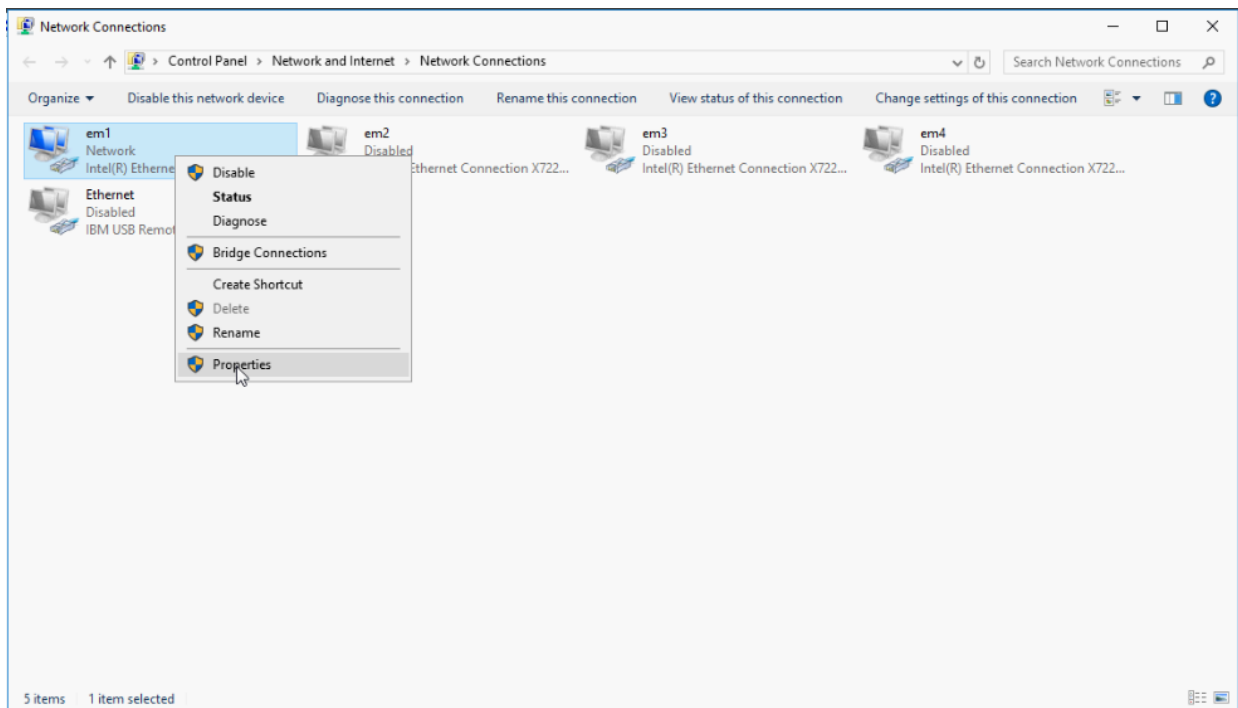

Figure 4-119

23. Make sure **IPv6** is **disabled** (unchecked).

24. Select **IPv4** and click **Properties**.

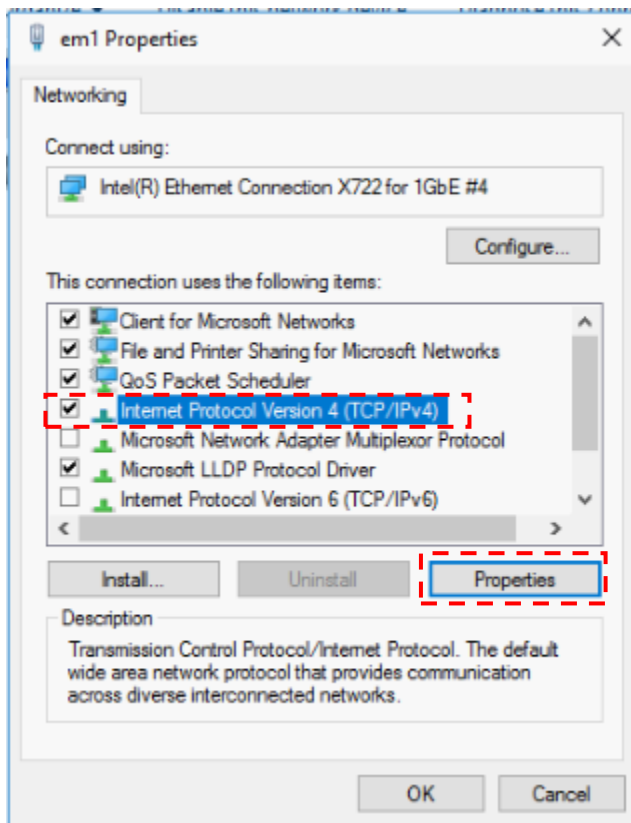

Figure 4-120

25. Make sure all network settings are correct.

The **DNS** IP address information can be found on the As-Built. Verify they are correct.

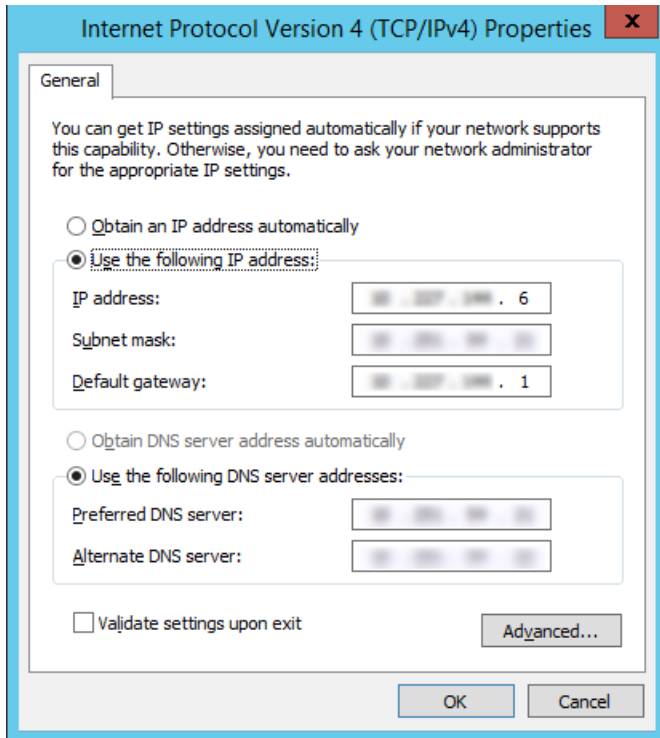

Figure 4-121

26. We will check the firewall status to make sure it is off. In order to check click on the windows icon and search for **Windows Firewall**.
  - a. It should be the second option, click on it
27. In **Windows Firewall** make sure the following setting match:
  - a. Private networks: Not Connected
  - b. Public networks: Connected
  - c. Windows Firewall state: Off
  - d. Incoming connections: Block all connections to apps that are not on the list of allowed apps
  - e. Notification state: Do not notify me when Windows Firewall blocks a new app

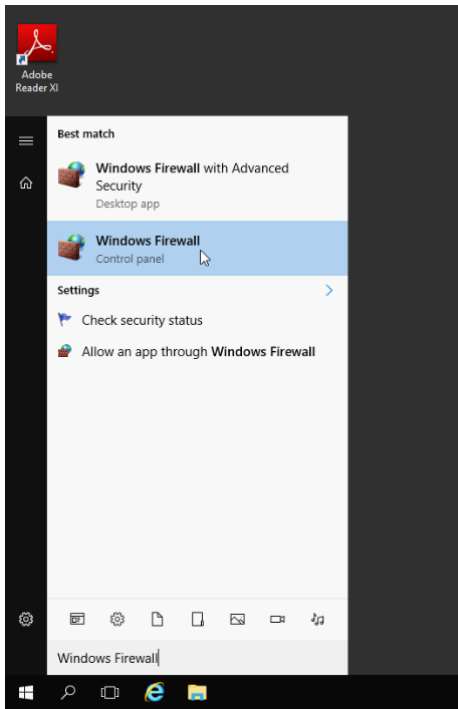

Figure 4-122

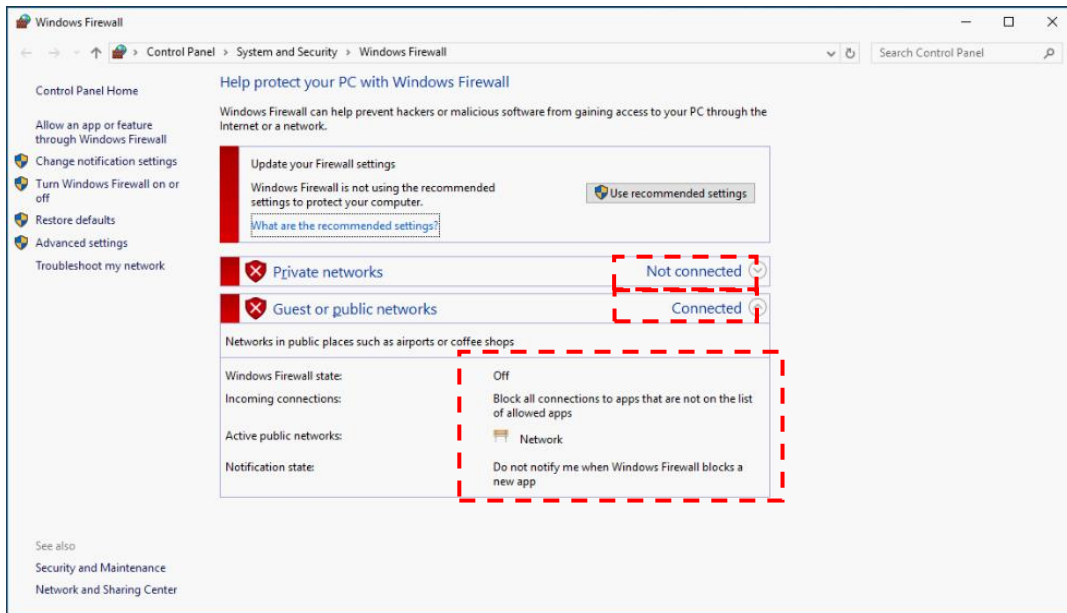

Figure 4-123

28. We want to make sure the NTP IP address is correct. Click on the windows icon and search for **date and time** and click on the first choice.
29. Click on Internet Time and make sure that it states **This computer is set to automatically synchronize with '10.251.38.51'**

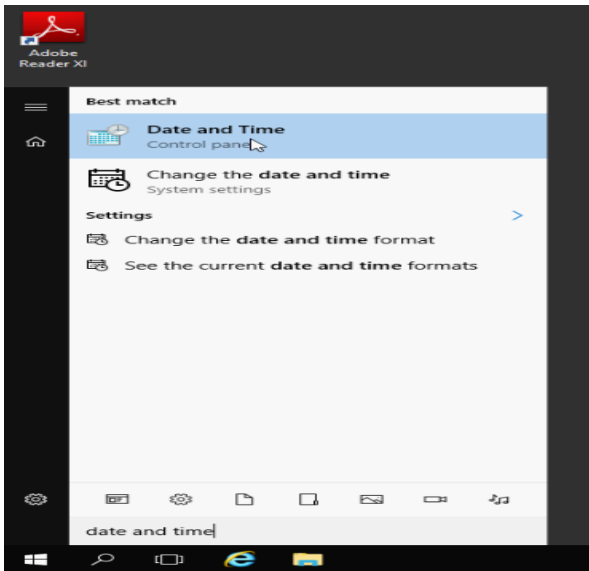

Figure 4-124

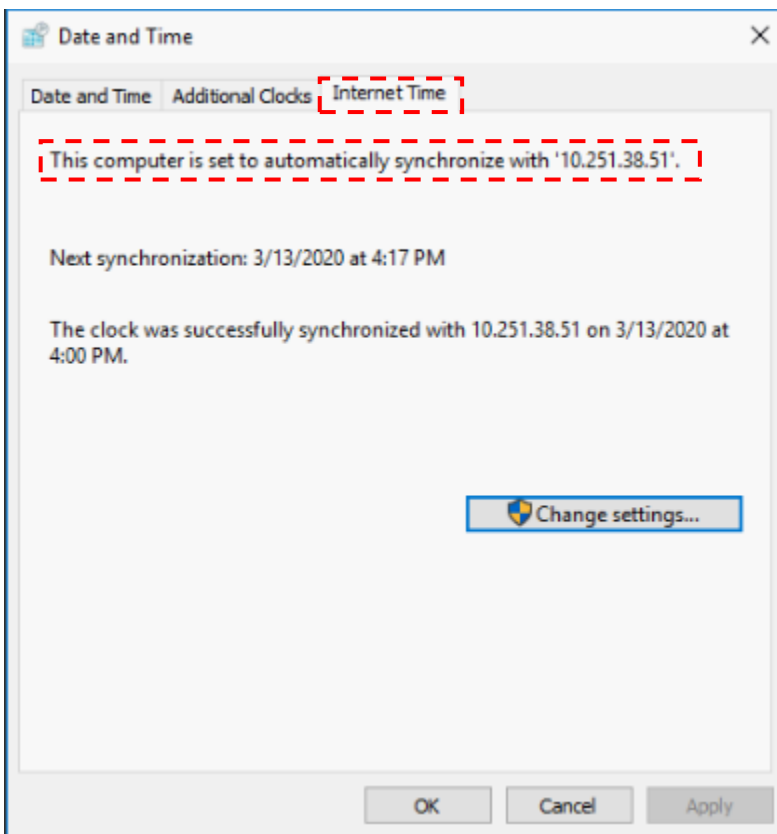

Figure 4-125

30. Now we will check to see if the other user accounts have been created. Click the windows icon and search for **other people**.
- f. Click on **Add, edit, or remove other people**
31. There should be a total of four accounts listed.
- g. **Evidence** – *Local Account*
  - h. **IPDVS** – *Administrator – Local account*
  - i. **NOC** - *Administrator – Local account*
  - j. **ipdvs\_scripts** – *Local account*

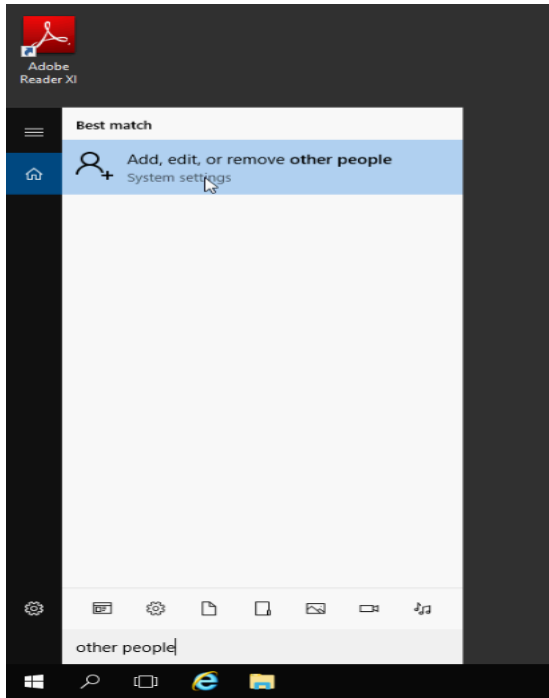

Figure 4-126

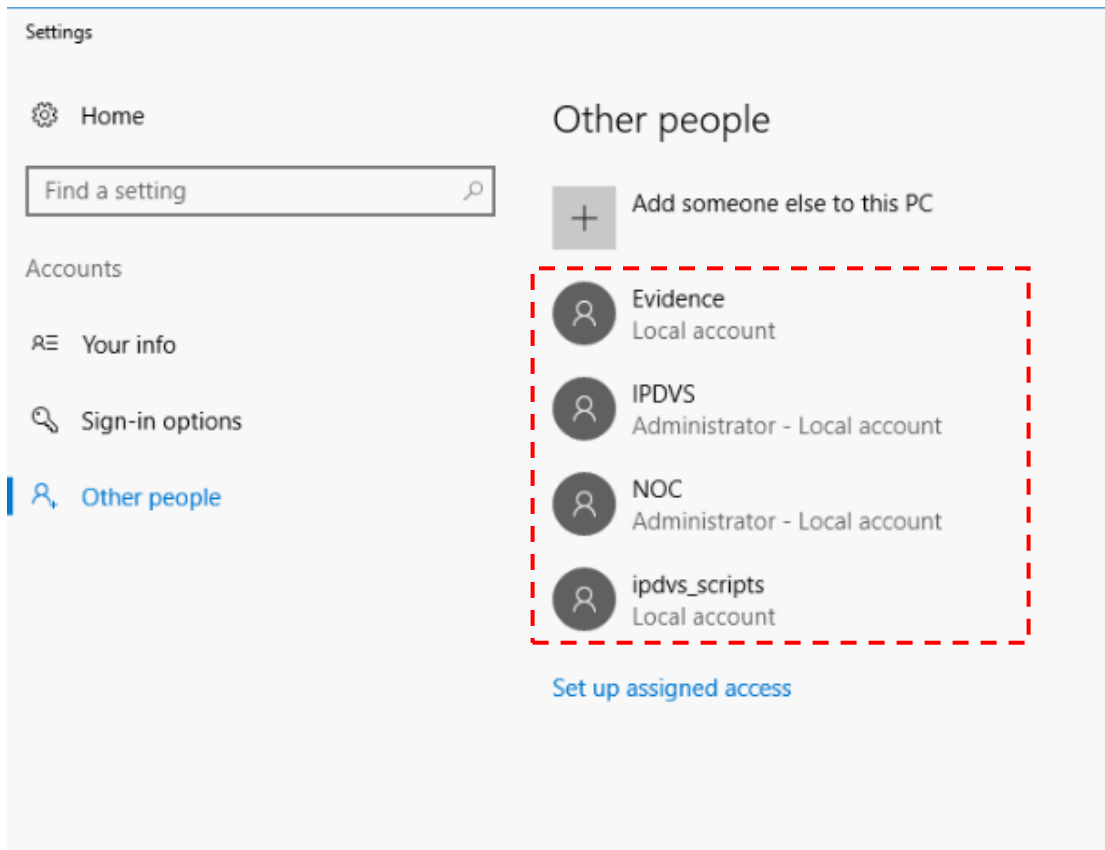

Figure 4-127

Device Labeling Requirements

IPDVS equipment must be labeled as follows

Device	Label Contents Description and Placement	Label Sample
Cisco Switch(s)	Label contents as follows: Cisco switch= <b>X plus a decimal number</b>  Affix label to front face of the switch.	<div style="border: 1px solid black; padding: 5px; width: fit-content; margin: 0 auto;">X16</div> Above is a sample label of a Cisco switch as it is assigned by the Engineering Support group at DIIT
IPDVS Server(s)	Label contents as follows: Primary [.6] Server= <b>Building Code-IPDVS-S1</b> Secondary [.7] Server= <b>Building Code-IPDVS-S2</b>  Affix label to the <b>top</b> of the server in the front left corner above power button.	<div style="border: 1px solid black; padding: 5px; width: fit-content; margin: 0 auto;">Q204-IPDVS-S1</div> Above is a sample label if this is the primary IPDVS server whose IP octet ends in [.6]
UPS(s)	Label contents as follows: Primary server UPS= <b>Building Code-IPDVS-UPS1</b> Secondary server UPS= <b>BuildingCode-IPDVS-PS2</b>  Affix label to the <b>Front</b> of the UPS just below the status light indicators.	<div style="border: 1px solid black; padding: 5px; width: fit-content; margin: 0 auto;">Q204-IPDVS-UPS1</div> Above is a sample label if this is the UPS that is powering the Primary IPDVS server.
AXIS Power over Ethernet Midspans known as Power	Label contents as follows: Midspan= <b>BuildingCode-Camera Name</b>	<div style="border: 1px solid black; padding: 5px; width: fit-content; margin: 0 auto;">Q204-E1-01</div>

Injector(s) only used for PTZ cameras	Affix label to front face of the Midspan.	Above is a sample label if this is the Midspan that is powering PTZ camera E1-01
---------------------------------------	-------------------------------------------	----------------------------------------------------------------------------------

Figure 4-128 – IPDVS Device Labeling

## SECURITY CENTER VIEWING WORKSTATIONS AND USER ACCOUNTS

This section describes the guidelines and restrictions for users and the workstations that will be used to access the IPDVS system.

### Security Center User Accounts

Each authorized IPDVS user, may only access Security Center to view cameras from a single workstation at a time. The standard IPDVS configuration provides the capacity for up to six (6) authorized users within a school building to login simultaneously to view the cameras. The configuration for sites that serve as the primary location of three or more co-located DOE schools may be enhanced to provide capacity for up to eight (8) simultaneous logins.

While it is possible to install the viewing software on a greater number of workstations than a site's simultaneous login limit, it is recommended that the maximum number of user accounts per site be limited to the greater of six (6) or two plus double the number of school organizations with their primary location at the site (2+2 x # of schools). For sites with seven or more school organizations, the recommended maximum number of user accounts is sixteen (16).

### Main Viewing Station (MVS)

The IPDVS MVS is a workstation provided by the IPDVS program during the initial installation or during a technical refresh upgrade for the dedicated purpose of accessing the Security Center application. This workstation must be placed on the IPDVS VLAN without exception and will not have access to the internet, E-mail, ATS or other networks or applications.

The 2021 Security Center MVS workstation is as follows

FAMIS ID	356215559 (School image FAMIS #)
Description	Lenovo P330 workstation with 21.5" dual monitors
FAMIS Price	\$1,445.35

The Lenovo P330 has been selected for the IPDVS viewing station primarily because it features a high-end video card that enhances digital video clarity.

Required specs include Intel i7-8700 CPU, 16GB Memory, NVIDIA Quadro P4000 video card, 256GB SSD primary Drive + 2TB Secondary Drive, , 3yr onsite warranty

Specified on FAMIS as "Only for SCHOOL Sites - IPDVS VIDEO SURVEILLANCE ONLY - SCHOOL IMAGE"

MVS Supported Operating Systems

1. Security Center Sites
  - a. The MVS should only run Windows 10 - 64 bit
  - b. No other OS is supported
  - c. Disable wireless card, IPDVS does not support using Wi-Fi

#### Charter School Viewing Station

\*\*\* Non-public schools and/or Charter schools should contact vendor for guidance on purchasing viewing station if unable to purchase through FAMIS\*\*\*

The IPDVS application may be installed on one charter school workstation meeting these conditions:

1. The machine meets or exceeds the minimum workstation specifications.
2. The machine is a supported workstation platform.

Restrictions:

1. The charter school viewing station must be configured with a static IP address on the IPDVS VLAN.
2. The workstation must be dedicated solely to IPDVS viewing. The machine will not have access to the internet, email or other networks.

#### Custodian Viewing Station

Per Division of School Facilities policy, the IPDVS viewing application may not be installed on a DSF issued CE workstation. DSF utilizes a standard software image for support purposes and, at this time, IPDVS is not included. The viewing application may be installed on any other non-DSF issued workstation that the custodian may have in his/her office that meets or exceeds the minimum IPDVS workstation specifications.

#### Administrative Workstations

The IPDVS application may be installed on NYCDOE administrative workstations meeting these conditions:

- a. The machine meets or exceeds the minimum workstation specifications.
- b. The machine is a supported workstation platform.

Restrictions:

1. Administrative workstations used for IPDVS viewing may not pull more than ten (10) simultaneous live video feeds. Viewing large numbers of live feeds from administrative workstations can overwhelm the intra-VLAN firewall at some locations and degrade network performance of all the administrative VLAN users.
  - a. If viewing of more than ten (10) cameras is necessary, a dedicated IPVDS system will be required to be placed on the IPDVS VLAN for the sole purpose of viewing the IPDVS system. Dedicated IPDVS systems do not have access to the internet, Outlook, ATS or any other applications.

The 2021 recommended administrative workstation options for IPDVS use is as follows:

FAMIS ID        356215559 (School image FAMIS #)

Description      Lenovo P330 workstation with dual 21.5” monitors  
FAMIS Price      \$1,445.35

Specified in FAMIS as “Only for SCHOOL Sites - IPDVS VIDEO SURVEILLANCE ONLY - SCHOOL IMAGE”

#### Windows 10 Support for IPDVS

Windows 10 is supported for IPDVS viewing stations within the following guidelines:

Windows 10 support is not available for workstations that did not arrive with a DIIT provided Windows-10 image preloaded.

1. Security Center School Sites
  - a. The MVS should only run Windows 10 – 64 bit.
  - b. Windows 10 administrative workstations run Security Center natively without the need for a virtual machine.
  - c. Disable wireless card, IPDVS does not support using Wi-Fi
  
2. Security Center Central admin sites use a Central Windows image, the FAMIS ID is 356215602 for the workstation and dual monitor bundle

#### Minimum Workstation Specifications

Workstations must meet these minimum specifications to run the Security Center IPDVS application:

**Processor:**      Intel®P Core I-7 8700 CPU  
**Memory:**        16.0GB RAM (Dedicated System Memory - Not Shared with Video VRAM)  
**Video Card:**    Nvidia P4000 8 GB (4xDP) GDDR5 VRAM PCI-Express 3.0 x16 Video Adapter (Dedicated Graphics Card)

Workstations failing to meet these minimum specifications will not be supported by DIIT.

#### Non-Supported Workstation Platforms

Due to technical and resource constraints DIIT does not support the Security Center IPDVS application on these platforms:

1. Laptops (Any)
2. Apple Macintosh workstations (Any, including Dual Boot Windows or Virtual PC Windows)
3. Non-Microsoft Windows Operating Systems (e.g. Linux, Unix, Other)
4. Microsoft Vista, and/or any OS versions prior
5. Wireless connected workstations (Any)
6. Tablet devices (Any)
7. Mobile devices (Any)
8. Disable wireless card, IPDVS does not support using Wi-Fi

## ***Legacy Camera Systems***

NYCDOE recognizes some security camera systems were installed prior to the initiation of the IPDVS project in 2005. These antiquated systems are referred to as "Legacy." IPDVS projects initiated during the first ten years of the project deployed analog cameras. Beginning with the publication of version 7.0 of the IPDVS standards projects are deploying digital IP cameras. Legacy and Analog equipment must be specified for removal from the building at the completion of the current installation with digital cameras. This section explains how to identify and remove Legacy and Analog Infrastructure.

### **Identification of Legacy and Analog Infrastructure**

Existing systems will not be considered for integration into the current IPDVS support program. These requirements will help identify Legacy and Analog. Upon request, DIIT will perform an assessment of any legacy or analog camera system and provide a recommendation report.

#### Legacy Removal General Requirements

1. No legacy CCTV type DVRs, VCRs, sequencers, multiplexers or directly connected video displays/viewing clients are to remain in use once the new IPDVS system is integrated.
2. No legacy video consoles, unsupported type cabinets, power supplies, surge suppressors, coaxial cameras (fixed or ptz), camera housings, camera mounts, and any serial based equipment are to remain in use once the new IPDVS system is integrated.
3. Legacy video cabling shall always be terminated in a wall. Any remaining coaxial cabling or other unsupported type cabling shall be removed.
4. Above equipment is to be disconnected, removed and turned over to the DIIT.
5. Compliance will be measured by DIIT to determine if the legacy equipment removal was completed in a supportable manner.

#### Analog Removal General Requirements

1. No analog cameras, camera wall mounts, Altronix power supplies, CCTP chassis, NVTs, VPUs are to remain in use once the new IPDVS system is integrated.
2. No unsupported servers, unsupported expansion servers, KVMs, non-standard IDF/MDF cabinets, non-standard racks, unsupported UPS equipment, PDUs, lightning suppressors, unsupported switches are to remain in use once the new IPDVS system is integrated.
3. Above equipment is to be disconnected, removed and turned over to the DIIT.
4. Compliance will be measured by DIIT to determine if the analog equipment removal was completed in a supportable manner.

#### Documentation Requirements

1. Manifest to be turned over to DIIT listing all legacy and/or analog equipment removed.

### ***Commissioning and Transfer of Ownership***

DIIT will commission all IPDVS implementations as part of the transfer of support ownership from the SCA or installing vendor to NYCDOE. Assessment should only be requested when a site is considered completely production ready from the end user perspective.

## Required Submittals

The list of transmittals below is not exhaustive but represents the minimum criteria that must be satisfied before a site assessment visit will be scheduled.

1. The DIIT IPDVS As-Built\_Submit.xls file must have been merged into production by QA & Engineering Support group
  - a. No required cells may be left blank. Assessments will not be performed against incomplete files.
    - i. This includes information that is to be provided to the SI by the AI and/or Contractor including: Camera Manufacturer, Camera Model Number, Lens Focal Length, and Exterior PTZ Power Supply Locations.
  - b. Do **not** send any copies of this document directly to IPDVS support.
2. The IPDVS design plans in AutoCAD format (dwg)
  - a. Must demonstrate camera positions and fields of view.
  - b. Doors, Pillars, Ramps, Low Ceiling Beams, separate roofs on any floors, etc.
  - c. Must be native AutoCAD format only.
  - d. All layers and reference points must be merged and included in the AutoCAD file.
3. The IPDVS User and Workstation form must have been submitted to IPDVS Support
4. Key package transmittal
  - a. Must include all M11 Keys and/or APC, the console cabinet keys if a console was installed and the keys to any locking pull boxes the Contractor or AI may have installed.
5. Cable certification test data
  - a. The printed passing certification test results, downloaded from the FTE, must be submitted to IPDVS support for all permanent link cable segments installed for the IPDVS project. This printed report must be submitted prior to an assessment being requested.
6. Copy of the Microsoft purchase order for the IPDVS servers
7. Genetec Site System ID License & Federation License.
8. Transmittal on training date by the SI and what staff was present.

## Self-Assessment Recommendations

Prior to requesting an assessment from DIIT, it is strongly recommended the self-assessment reviews below be performed. These items are accumulated from lessons learned that have delayed prior assessments from achieving full transition to DIIT upon completion of the review. These are not required to be completed to request an assessment, but failure to do so may significantly delay site transition to the IPDVS support program.

### System Integrator

1. Confirm the As-Built\_Submit.xls has all required data fully populated including data that the AI or contractor are required to provide to the SI.
2. Confirm the As-Built data matches the Config Tool data completely and verbatim.
3. Confirm the Config Tool *Descriptions* field for cameras.
4. Confirm UPS can be logged into and displays status.
5. Confirm IMM card can be logged into and temperature reading obtained.
6. Confirm Security Center setup and naming conventions are complete and accurate.
7. Confirm RAID setup is complete and accurate.

8. Confirm Windows Disk Volume setup is complete and accurate.
9. Confirm PTZ camera functionality through the application.
10. Confirm User and Workstation Transmittal letter, Microsoft purchase order for SQL licenses sent to IPDVS Support.
11. Confirm all patch cords are provided to all required network devices.

#### Authorized Installer

1. Confirm all cameras have video all the way to the patch panel port when tested with a field monitor.
2. Confirm all cameras are clearly focused.
  - a. Use the electronic autofocus feature to perform this focus. Use the Calibrate Optics feature to resolve focusing issues.
  - b. Confirm Dome/Housing screws are aligned and tightened down properly when completed.
3. Confirm all PTZ cameras exhibit control all the way to the IDF patch panel port when tested with a handheld controller or equivalent.
4. Confirm all cameras are aligned per the design and captures the intended field of view.
5. Including removal of excess lighting/ceiling at the top of the field of view and excess wall from the sides.
6. Including verifying the plane of the floor is parallel with the bottom of the field of view (no crooked views).
7. Confirm all gimbals set screws are tightened down once camera is aligned as desired.
8. Confirm all cameras have been programmed per standards for low light, sensitivity, etc.
9. Confirm all parapet mounted exterior cameras extend the whole of the camera body over the parapet.

#### Electrical Contractor

1. BEFORE INSTALLING THE SERVER CABINET: confirm that the front of the cabinet and back of the cabinet are oriented correctly. Backwards cabinets will not be accepted. **Note:** Rail mounted equipment cannot slide out of a backwards cabinet for service.
2. Confirm all Middle Atlantic cabinet locks have been replaced with the standard M11 lock cylinder.
3. Confirm a brass Medeco retaining nut was used to replace the original Silver Spring clip.
4. Confirm all IPDVS dedicated outlets have been labeled for both the originating power panel identifier and circuit breaker identifier.
5. Confirm all IDF 4.5" cabinet fans are installed and operational (exhausting outwards/upwards).
6. Confirm the Server cabinet 10" fan is installed and operational (exhausting outwards/upwards).
7. Confirm video cable runs are not terminated onto data patch panels.
8. Confirm data cable runs are not terminated onto video patch panels.
9. Confirm all patch panel ports are labeled on the panel with the camera identifier.
10. On new panels installed for the IPDVS project, confirm no patch panel ports were skipped or damaged. All ports are to be filled in sequence and no patch panels with 'bad' ports are acceptable for transition to NYCDOE.

#### Maintenance of Camera Dome

The following FAQ (115623) may also be found on the Axis website.

How do I keep the dome clean?

Cleaning of dome cover:

- Be careful not to scratch or damage the dome cover. Do not clean a dome cover that looks clean to the eye and never polish the surface. Excessive cleaning can damage the surface.
- For general cleaning of a dome cover it is recommended to use a non-abrasive, solvent-free neutral soap or detergent with water and a soft cloth. Rinse well with clean lukewarm water. Dry with a soft cloth to prevent water spotting.
- Never use harsh detergents, gasoline, benzene or acetone, etc. and avoid cleaning in direct sunlight or at elevated temperatures.

Cleaning of the dome is also described in the installation guidelines.

## Section 5: School Network Server

---

### Overview

The following step by step procedure will help Deployment Field Engineers to setup and install Lenovo Server SR630 in the school.

For technical assistance contact QA Helpdesk (718) 935-5469 or (718) 935-5591, Server Operation (718) 935-5483

### Important:

This instruction document will only work with the following Machine and Model Type:

- Lenovo Server ThinkSystem SR-630

### Physical Hard Drive Setup

#### Server Verification

Collect the following information before you start the imaging process. The following information can be seen from the front panel of the server as shown below:

- Machine Type
- Model Number
- Serial Number

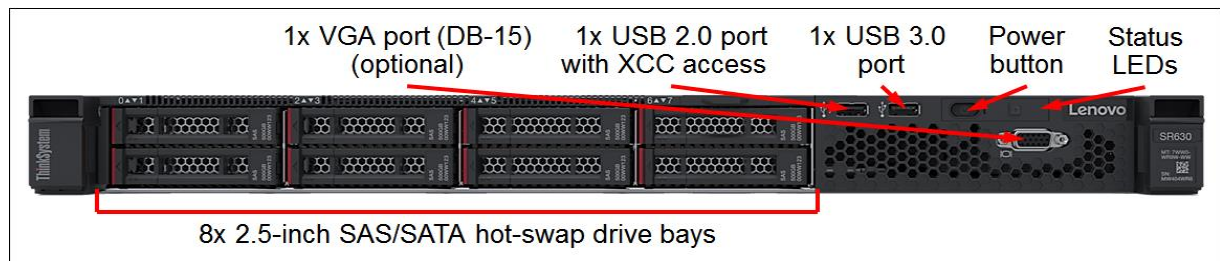

**Figure 5-1: Front View of Server**

Check the collected information from the servers against the list that you were provided to you. The reason for collecting this information is to make sure that the Technician works on the right server. If you are not sure which server will be imaged, please call QA Helpdesk for information.

**Table 5-1: Hard Disk Drives Setup**

Drive Number	Drive Size	Drive Slot
1	300GB	0
2	300GB	1
3	1TB	2
4	1TB	3
5	1TB	4
6	1TB	5
7	1TB	6
8	1TB	7

Insert eight (8) Hard Drives into slots “0 ~ 7” as per the above chart.

Power On the server by pressing the **Power Button** (located on the right side of the server).

### ***Integrated Management Module Setup***

The following images will demonstrate how to configure and setup the XClarity Controller card on the Lenovo server.

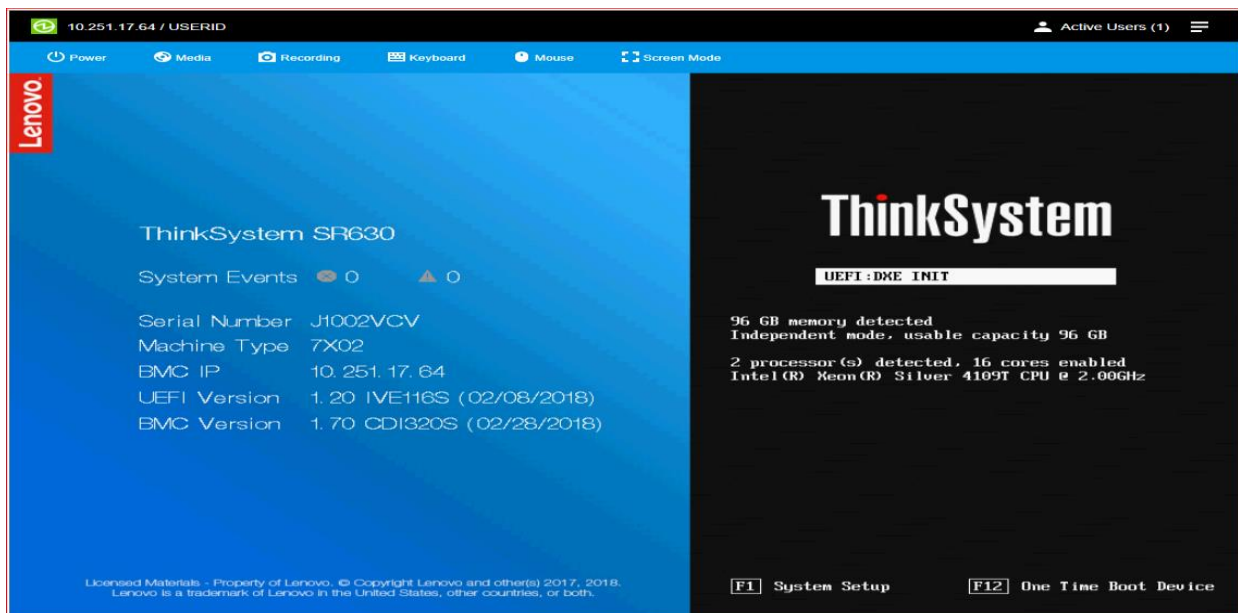

**Figure 5-2: XClarity Controller Setup Starts**

When you turn on the server, press F1. You will see the above screen. (If you don't see the above screen, restart your server.) F1 will take you to the **System Configuration and Boot Management** screen where a Technician can setup the XClarity Controller (aka Remote Card).

**Note:** When you press F1, you will see the above screen. (If you don't see the above screen, restart your server.) F1 will take you to the ThinkSystem Setup screen where Tech can setup XClarity aka Remote Card.

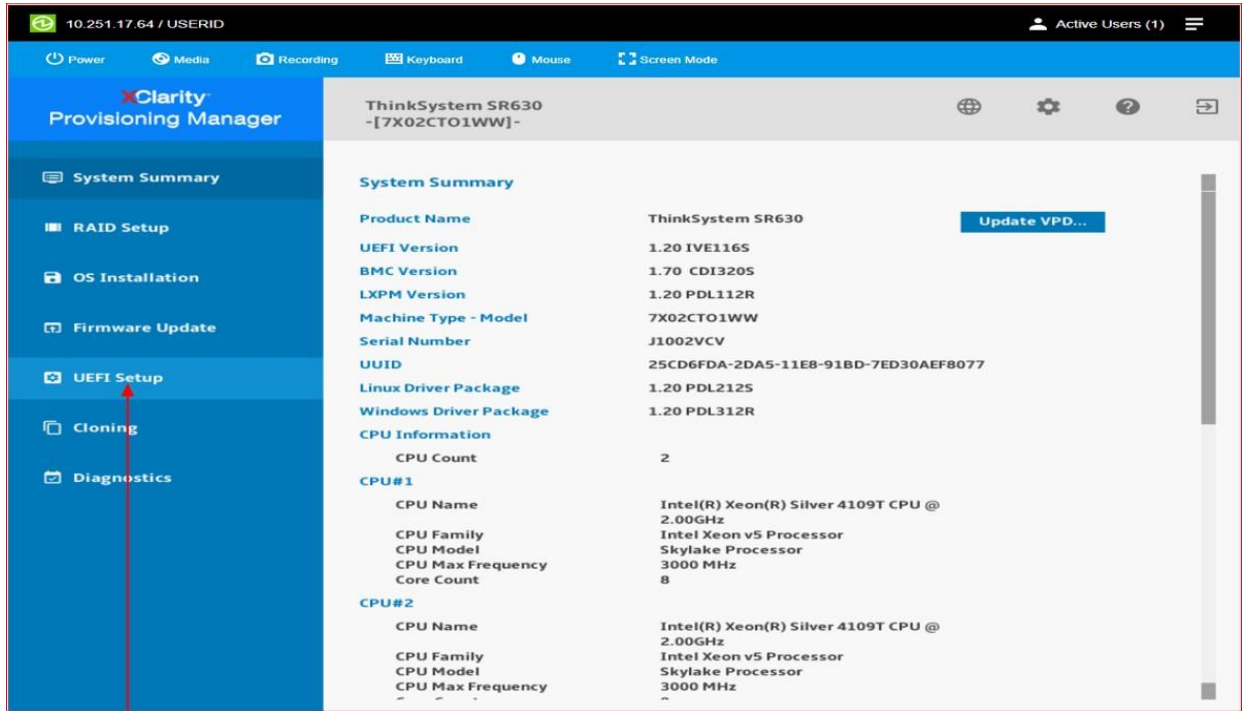

**Figure 5-3: XClarity Provisioning Manager (step 1)**

Click on UEFI Setup.

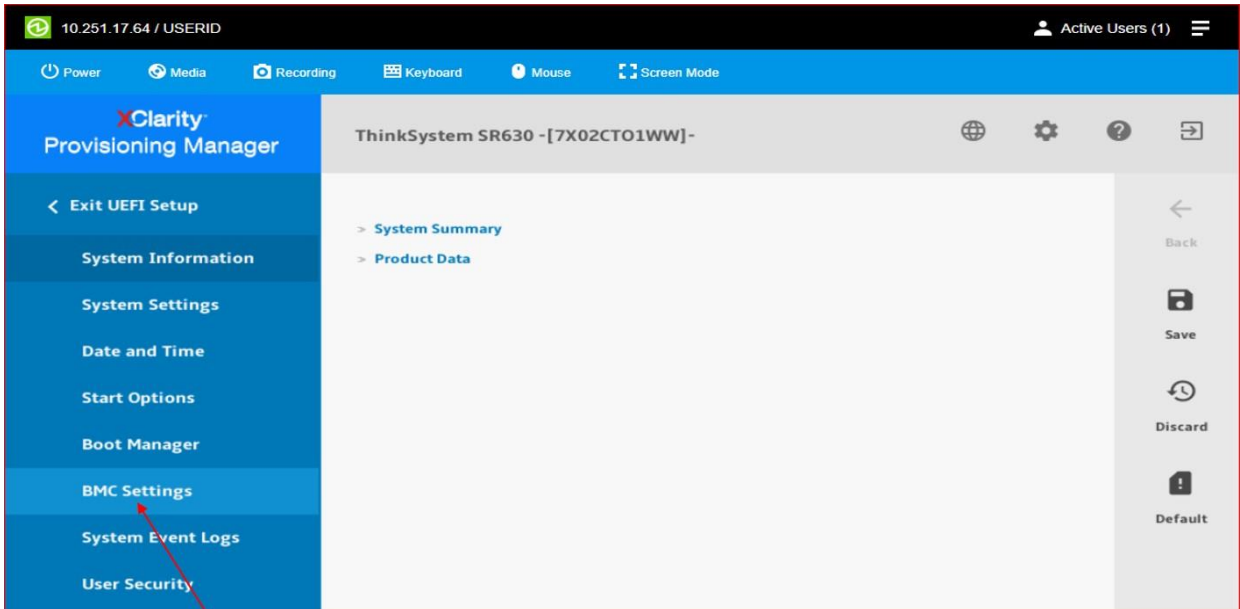

Figure 5-4: XClarity Provisioning Manager (step 2)

Click on BMC Settings to continue.

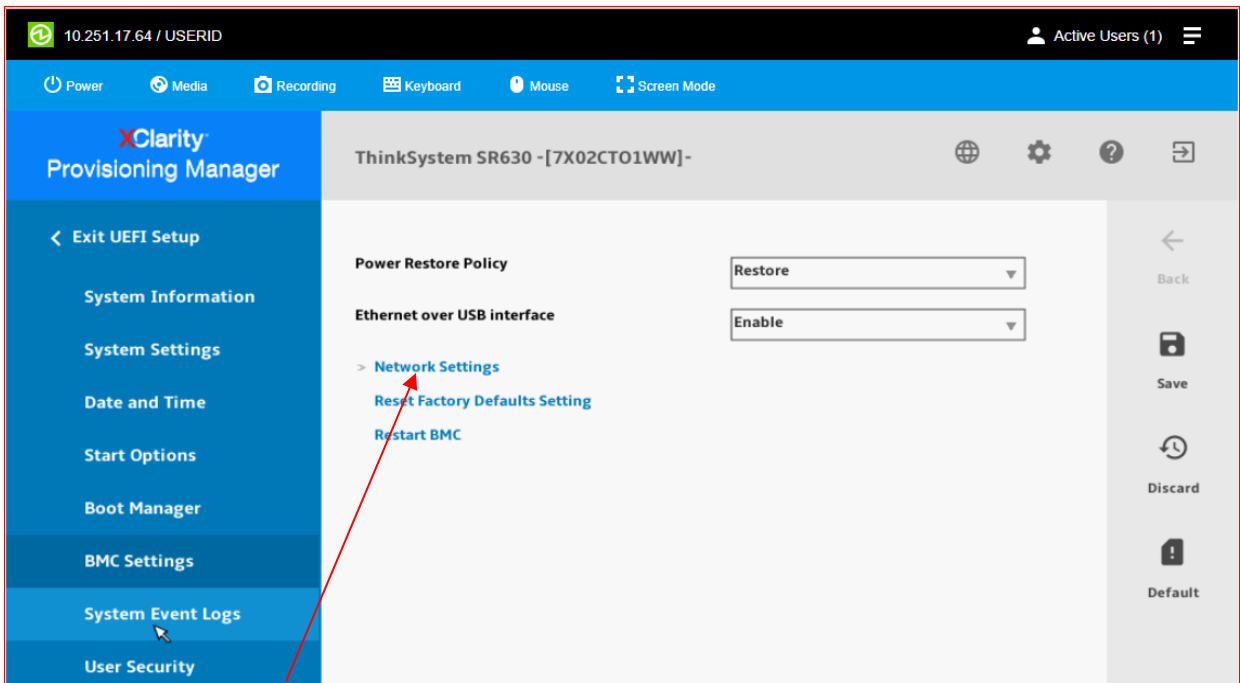
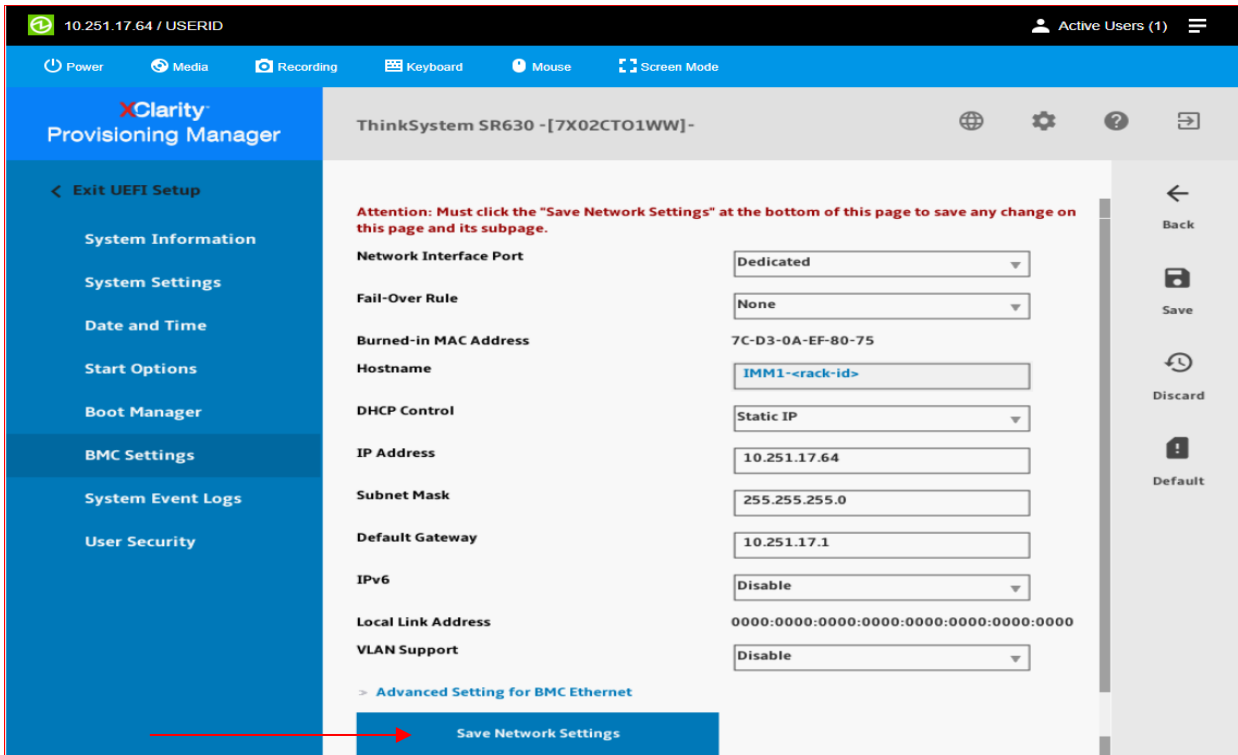

Figure 5-5: XClarity Provisioning Manager (step 3)

Click on Network Settings to continue.



**Figure 5-6: XClarity Provisioning Manager (step 4)**

Make sure to change the following settings:

- Hostname (host name should be rackid-IMM1 for Host01)
- DHCP Control to Static IP
- IP Address (Enter IP Address as provided by NYCDOE)
- Subnet Mask (Enter IP Address as provided by NYCDOE)
- Default Gateway (Enter IP Address as provided by NYCDOE)
- Press Save Network Settings icon. Reboot the Server and boot to Windows 2019.

Let the Lenovo Server boot and it should take about 10 – 15 minutes to see the Logon Screen (see Figure 5-2).

**Table 5-2: IMM1 IP Address Configuration**

IMM IP Address Configuration	
IMM1 IP Address	10.xx.xx+15.222
Subnet Mask	255.255.255.252
Gateway Address	10.xx.xx+15.221

## Network Connection for Host-01

There will be 5 cables per server. Here is the setup for the 5 cables of Host-01. (refer to Figure 5-7)

### Cable #1

- Take the 1<sup>st</sup> Ethernet cable and insert one end of the network cable into the **1<sup>st</sup> from the leftmost** NIC port of the server and the other end connect to port **10** on Cisco **X0** switch. (**X0** is connected to Cisco switch 9500 via DAC cable)

### Cable #2

- Take the 2<sup>nd</sup> Ethernet cable and insert one end of the network cable into the **2<sup>nd</sup> from the leftmost** NIC port of the server and the other end connect to port **11** on Cisco **X0** switch. (**X0** is connected to Cisco switch 9500 via DAC cable)

### Cable #3

- Take the 3<sup>rd</sup> Ethernet cable and insert one end of the network cable into the **3<sup>rd</sup> from the leftmost** NIC port of the server and the other end connect to port **12** on Cisco **X0** switch. (**X0** is connected to Cisco switch 9500 via DAC cable)

### Cable #4

- Take the 4<sup>th</sup> Ethernet cable and insert one end of the network cable into the **4<sup>th</sup> from the leftmost** NIC port of the server and the other end connect to port **13** on Cisco **X0** switch. (**X0** is connected to Cisco switch 9500 via DAC cable)

### Cable #5 (XClarity Card)

- Take the 5<sup>th</sup> Ethernet cable and insert one end of the network cable into the XClarity port of the server and the other end connect to port **9** on Cisco **X0** switch. (**X0** is connected to Cisco switch 9500 via DAC cable)

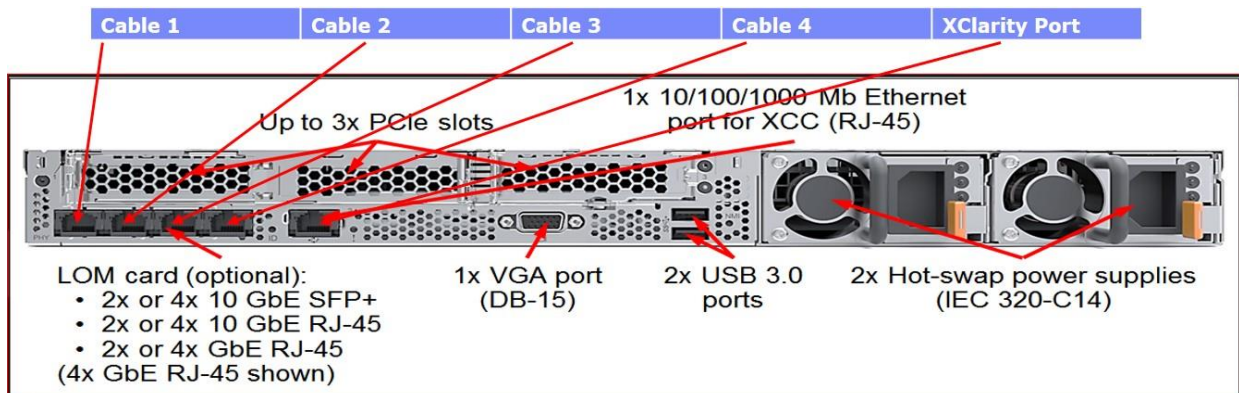
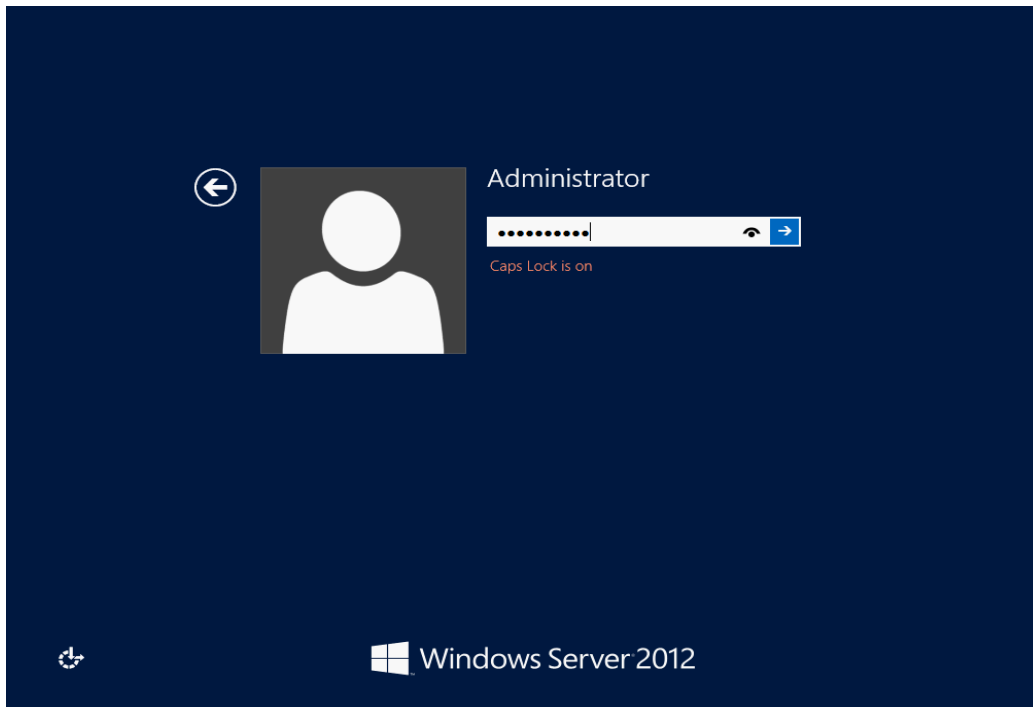

Figure 5-7: Host-01 Cable Setup

Reboot the server (Host-01) and let it boot to Windows 2019



**Figure 5-7: Logon Screen**

Once the boot process is completed, you will have to enter the following information.

Login ID: administrator

Password: 4MANAGE@27

The password should be all uppercase.

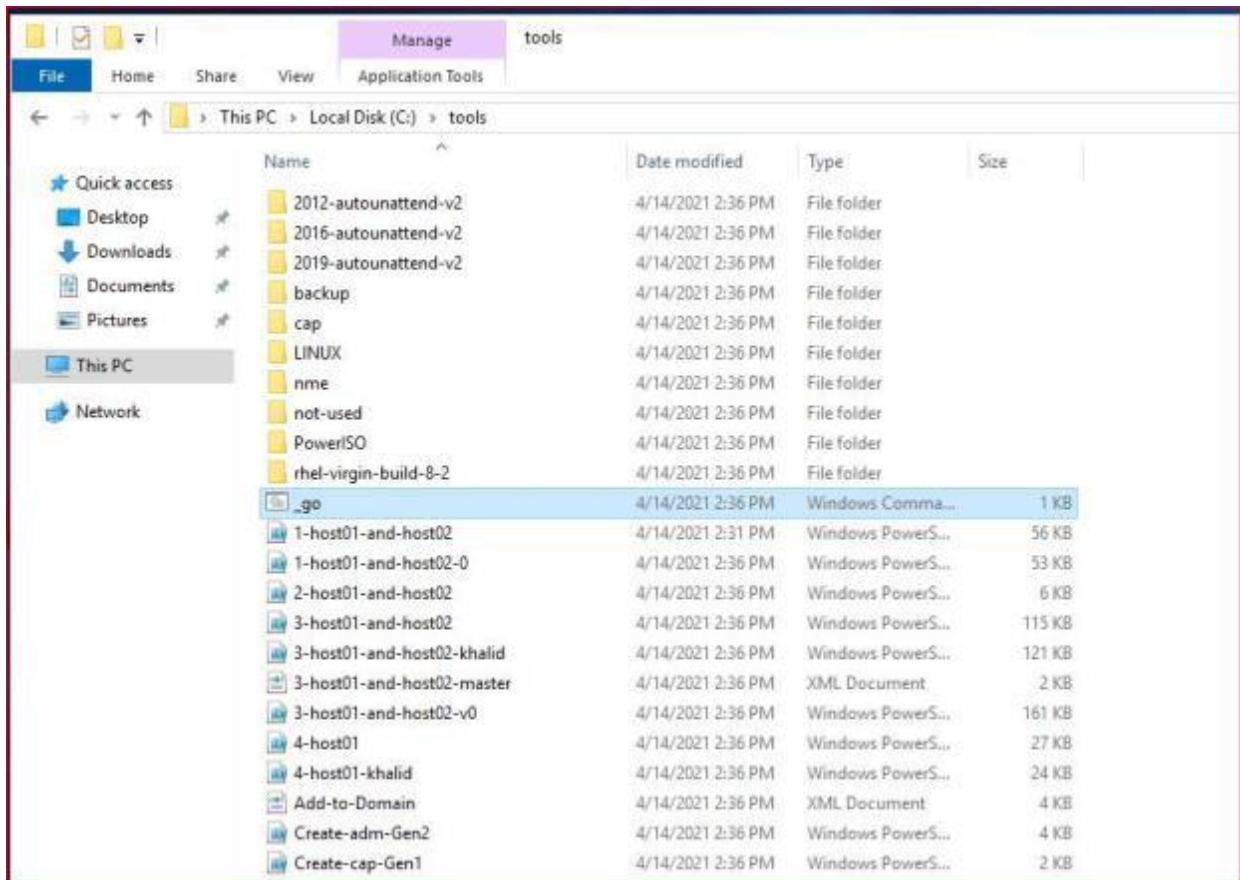

**Figure 5-8: Server Configuration**

Once the server is properly cabled and connected successfully to the network follow the steps to setup IP address configuration.

- Go to C:\tools Folder
- Locate the File “\_go.cmd” in the tools folder
- Right click on \_go.cmd, select Run as administrator

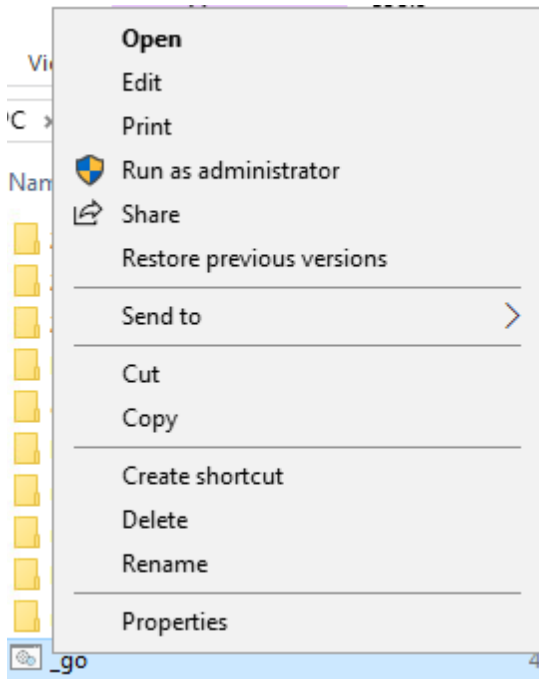

**Figure 5-9: Server Configuration**

Right click on **\_go.cmd**, select Run as administrator.

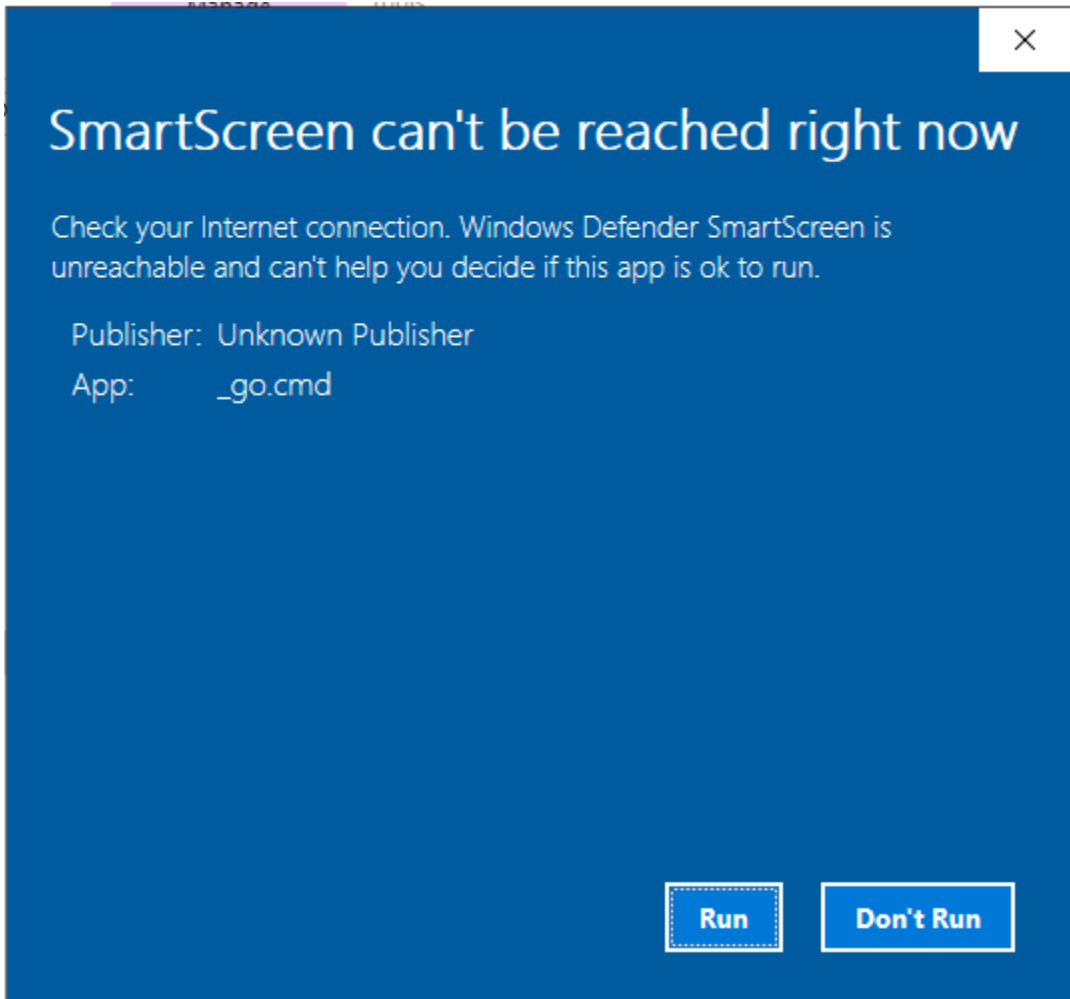

**Figure 5-10: Server Configuration**

If the server does not have access to the internet, you will see Figure 5-10. Click on **“Run”**.

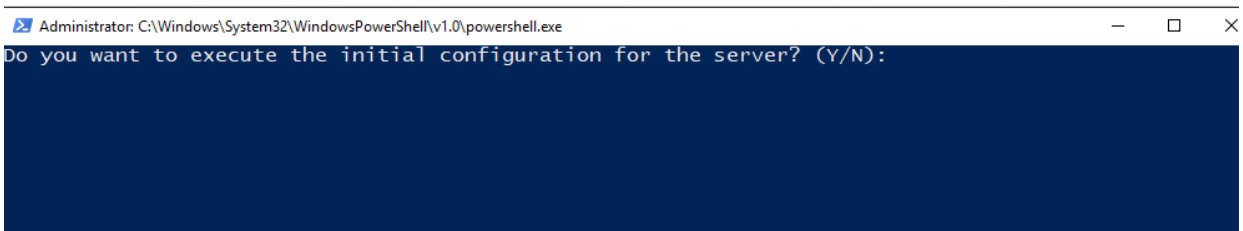

**Figure 5-11: Server Configuration**

```
The name of the computer is WIN-GOIPOKLVG40
INVALID Computer Name
INVALID Computer Name
Computer Name Format: RACKID-HOST01 or RACKID-HOST02 -- (e.g.; 12B345-HOST01 or 12B345-HOST02)
Use only Integers, Capital Letters, a hyphen, and either HOST01 or HOST02 .
Boroughs: B - Brooklyn, M - Manhattan, Q - Queens, R - Staten Island, X - Bronx
Enter the new name for the computer. (e.g.; 12B345-HOST01 or 12B345-HOST02): _
```

**Figure 5-12: Server Configuration**

```
Enter the first 3 octets only!!! from the Host Server's Instructional IP Address (e.g.; 10.xxx.xxx.
): _
```

**Figure 5-13: Server Configuration**

```
----- Set the correct date and time -----
Updating the time and date
Sleep Timer - 60 Seconds
4/27/2021 12:26:36 PM
On the taskbar - Are the date and time correct? (Y/N): _
```

**Figure 5-14: Server Configuration**

If the server has connectivity to the internet, the time should synchronize. Otherwise, you will need to manually set the time.

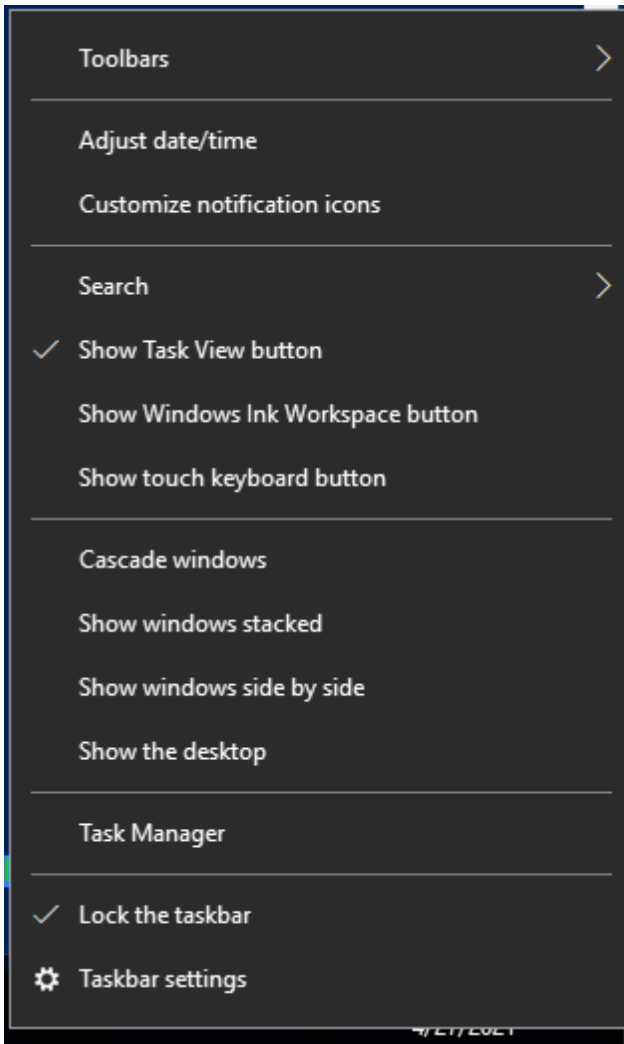

**Figure 5-15: Server Configuration**

To manually update the time, right click on date/time in the taskbar. Select **“Adjust date/time”**.

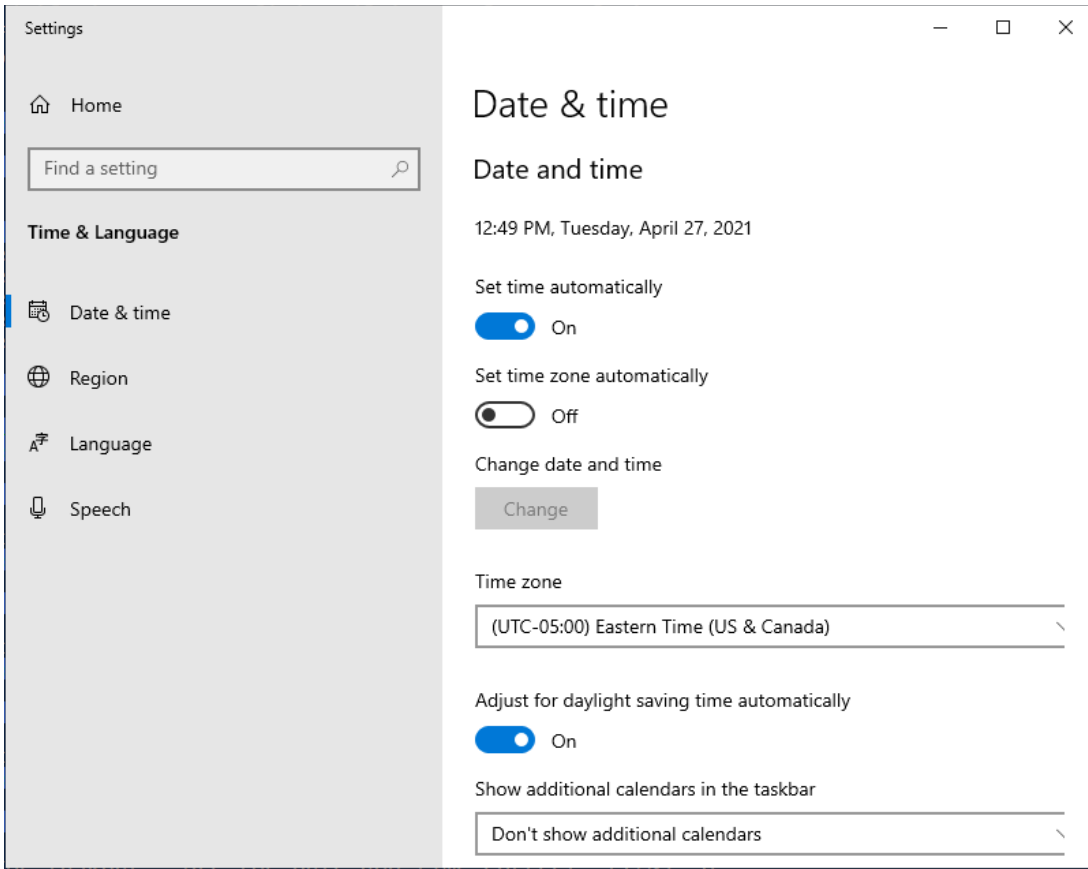

**Figure 5-16: Server Configuration**

Change set time automatically to **off** and after doing so, click on **Change**.

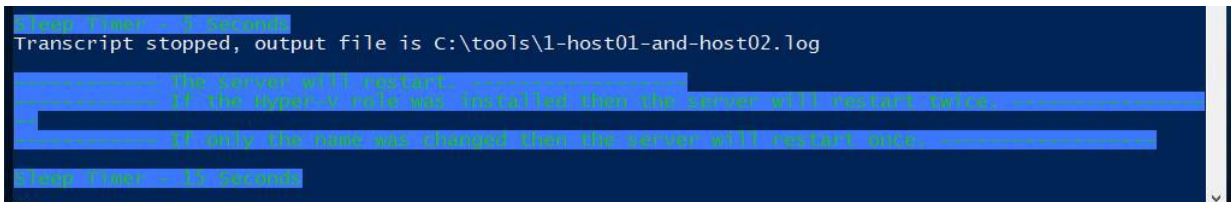

**Figure 5-17: Server Configuration**

After the date and time window, you should see the screen in Figure 5-17.

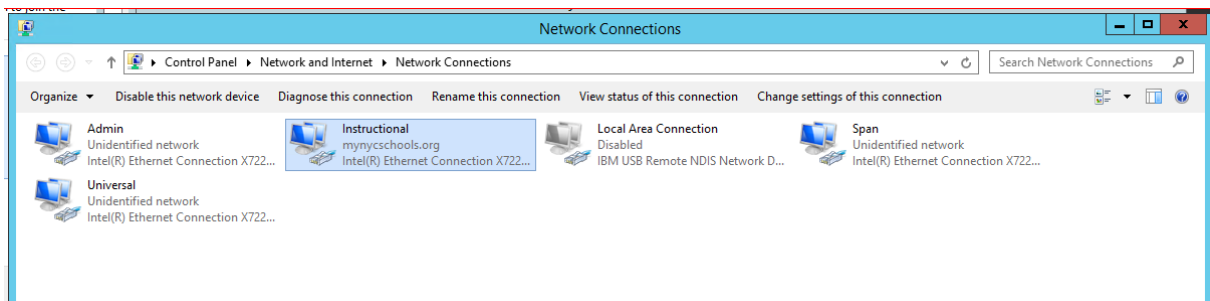

**Figure 5-18: Server Configuration**

## Verifications of Servers

### NICs and IMM

Make sure that all the NICs are enabled on both servers. To verify the network connectivity, ping google.com via a command prompt. If the Ping command fails, verify Instructional NIC is enabled or switch Port is active. Ping the IP address of the IMM from command prompt. If the Ping command fails for IMM, verify the switch port is active. For all network related troubleshooting, please call QA Helpdesk. Once all Pings are successful, call NYCDOE QA Helpdesk and request them to take over the server configuration.

**Table 5-3: Host01 IP Address Configuration**

Host-01 IP Address Configuration	
Host-01 IP address	10.xx.xx.208
Subnet Mask	255.255.255.0
Gateway Address	10.xx.xx.2

Table 5-4 provides a quick overview of the ports and VLAN information on Cisco core switch

**Table 5-4: Port Assignments**

Host-01	
Ports on X0 Switch	VLAN
Cable #1 – interface Tw1/0/10	1
Cable #2 – interface Tw1/0/11	2
Cable #3 – interface Tw1/0/12	3
Cable #4 – interface Tw1/0/13	Reserved
Cable #5 – interface Tw1/0/9	5

### Note\*

VLAN 5 is for XClarity card.

### Final Steps

Call QA Helpdesk and inform the Helpdesk that Imaging and installation of two Lenovo Servers is completed. Don't leave the school until the QA Helpdesk has full access to the servers.

## Section 6: School Networking

---

### **Overview**

The technology detailed in this document explains the technology currently being deployed by the DIIT in existing schools and the technology that should be deployed in new schools. DIIT administers to NYCDOE Central offices, schools and district offices as a service-oriented organization that provides on-demand, maintenance, preventative and advisory technical services for all levels of the organizational infrastructure. The New York City Department of Education is committed to providing a robust and scalable school network infrastructure. Building to the technology standards set forth in this document will enable a network that schools can build upon in the future which DIIT can continue to support and maintain. This document will establish a baseline for building future network architectures that can facilitate high availability, scalability and optimum performance.

### **Technology Descriptions**

Please plan and review multiple technology areas before performing construction at either a new or an existing site. Each technology area carries its own comprehensive list of components that are required to provide the needed functionality. When planning construction to new and existing structures, a checklist of components is required. When constructing a new site from the ground up, select the entire suite of network-infrastructure components based on the site classification to which the school will belong. These components include the following types of devices.

#### Core Switch

Each building has a core switch with fiber uplinks making it possible for the Layer 2 edge switches to connect to the core.

In a multi-tiered environment, the core switch provides an aggregation point for all internal traffic and provides Layer 2/3 functionality. The architecture no longer divides the school LAN network into three independent networks - Instructional, Administrative & Service. The network has been combined into one. The configurations defines the network on the core switch.

Depending upon the school size, DIIT specifies different core-switch models:

- Small Schools -> C1111-8PWB
- Medium Schools -> C9500-48Y4C
- Large Schools -> C9500-48Y4C

Each school needs copper connectivity inside the MDF for connecting infrastructure devices such as servers. In the case of Medium, and Large schools with C9500-48Y4C as their core switch, it does not have any copper ports. Therefore, we need an additional MS390-48UX2-HW for copper connectivity (X0). All IDF switches connect to the core switch using fiber uplinks.

#### Router

At every school building, a router connects to the building's school LAN, the WAN circuits terminate on the router. All traffic to/from a school passes through this connection to the NYCDOE. Currently, each WAN

circuit provides for 300Mbps – 2Gbps committed bandwidth (CIR). Each WAN router connects to NYCDOE’s core via an EVPL circuit.

- Inbound: We configure router with static routes for the internal subnets pointing towards the WAN interface of the router. Inbound traffic from the core towards the school LAN uses these routes to reach school LAN.

### Edge switches

Access layer switches provide connectivity to computers, printers, access-points, cameras, time clocks, etc. Each switch connects to the core switch using one multimode fiber pair.

### Firewall

We no longer deploy a firewall to new or refreshed schools. Firewalling functionality has been moved. Firewalling is now being enforced in each switch port. Filtering is done to and from a school as well as between devices between at a school.

### Wireless Controller

We no longer deploy a wireless controller to new or refreshed schools. Access points are now controlled through the Meraki cloud.

### Wireless Access Points

Wireless access points act as a wireless gateway for the wireless users. These access points connect to the nearest access switch. Access-points support 802.11a, 802.11g, 802.11n, 802.11ac, and 802.11ax connectivity. These access-points register themselves to the Meraki Dashboard accessible online. Clients send data to the access-point and then to the access switch and finally to the core. The access-points receive power via POE on the access switches.

### Network Servers

Integrators install a Lenovo SR630 server at each site. These servers run Microsoft HyperV as their base operating systems. These HyperV servers host virtual machines with Windows and LINUX operating systems. These virtual machines host various roles like DHCP.

### Cisco Licensing Portal

Integrators must ensure all licenses are delivered to the DOE account on the Cisco smart license portal. To do this, these steps must be followed:

- go to <https://software.cisco.com>
- click on the link Request Access to an Existing Smart Account (in the Administration section)
- Enter DOE’s domain name (schools.nyc.gov) in the field provided
- Once one of the DOE administrators approve the request they can then go back to <https://software.cisco.com> and then click on Smart Software Licensing link (in the License section)
- At the upper right they have to select the NYCDOE smart account

Everything integrators need to know about how to deal with Smart Accounts is detailed in training lessons in the link Learn about Smart Accounts located in the <https://software.cisco.com> site.

Table 6.1 below is a matrix that lists each technology component for six technology areas. The rest of this section provides further details.

**Table 6.1: School Technology Areas and Components**

<b>Technology Area:</b>	<b>Technology Component(s):</b>	<b>New Site:</b>	<b>Retrofit Site:</b>
<b>Physical Connectivity Infrastructure</b>	School / Building Cabling Infrastructure: <ul style="list-style-type: none"> <li>• Horizontal Cabling (Data/ Voice PBX)</li> <li>• Riser Cabling (Backbone / High Density Areas)</li> </ul>	Required	Upgrade as needed
<b>WAN Connectivity Infrastructure</b>	Wide Area Network Connectivity: <ul style="list-style-type: none"> <li>• Data Center Aggregation Routers</li> <li>• Remote School Site Routers</li> </ul>	Required	Upgrade required
<b>LAN Connectivity Infrastructure</b>	School / Building Core Network Equipment: <ul style="list-style-type: none"> <li>• Switches</li> <li>• Layer 2/3 Router (LAN Routing)</li> <li>• vManage (LAN Security)</li> </ul>	Required	Upgrade required
<b>Network Components</b>	Standard Components: <ul style="list-style-type: none"> <li>• Cisco Core Switch: C9500-48Y4C</li> <li>• Cisco Core Switch: MS390-48UX2-HW</li> <li>• Cisco Access Switch: MS390-48UX2-HW</li> <li>• Cisco Router: Catalyst 8300</li> <li>• Wireless Controller: N/A</li> <li>• Wireless AP: Cisco Meraki MR57</li> <li>• Lenovo Network Server: SR630</li> </ul>	Required	Upgrade required
<b>Network Services</b>	<ul style="list-style-type: none"> <li>• DHCP</li> <li>• DNS</li> <li>• Wireless</li> <li>• Network Management Services</li> </ul>	Required	Upgrade as needed
<b>IoT Services</b>	<ul style="list-style-type: none"> <li>• LonWorks / Wonderworks</li> <li>• CAASS</li> <li>• POS</li> <li>• IPDVS</li> <li>• WTMC</li> <li>• ACEUM</li> <li>• Dashboard</li> <li>• EUM</li> <li>• Timeclocks</li> </ul>	Required	Upgrade as needed

## School Site and Room Classifications

School site and room classification (based on size) allows DIIT to provide a standardized design and offers simplified management post-implementation. Administrative sites, such as 2 MetroTech Center (2MTC), follow different standards as described in a separate networking standards document for the administrative buildings.

### School Types

There are currently two school types: Charter School, and Public Schools. There are two classes of Charter Schools:

1. Charter Schools provided with network equipment that only supports DFS & ATS Services and
2. Charter Schools provided with network equipment that support full access to NYCDOE administrative applications.

**Table 6.2: Site Classification Summary – Charter Matrix**

Criteria	Charter School	
	DFS & ATS	Full Admin & Services
Admin Users	Yes	Yes
Instructional Users	No	No
IOT Devices	No	Yes
District Office Capable	No	Yes
IPDVS	Yes	Yes
Network Services Support (DHCP)	No	Yes
WAN Technology	Cable Modem / FIOS	EVPL
Tunnel	VPN	EVPL

There are multiple classes of Standard Schools based on size. Here is a site-classifications are summary.

**Table 6.3: Site Classification Summary – School Building Matrix**

Criteria	Standard Schools		
	Small	Medium	Large
Number of Students	<40	<= 1,000	> 1,000
Maximum APs	4	N/A	N/A
Admin Users	Yes	Yes	Yes
Instructional Users	Yes	Yes	Yes
IOT Devices	Yes	Yes	Yes
District Office Capable	No	Yes	Yes
IPDVS	Yes	Yes	Yes
Network Services Support	No	Yes	Yes

WAN Technology	Cable Modem / FIOS or EVPL	EVPL	EVPL
Tunnel	VPN (None for EVPL)	No	No

#### Charter School Site Deployment

- Charter School Site to Support DFS & ATS only Deployment

Charter Schools in this category do not require Instructional VLANs connecting to NYCDOE network. Routers, provided by the NYCDOE, will allow these schools to connect to the NYCDOE network using VPNs in order to access the DFS & ATS Services. The school will connect to Internet using service provided by residential or commercial Broadband Internet service providers.

- Charter School Site to Support Full Admin VLAN Deployment

Charter Schools in this category do not require Instructional VLANs and connections to NYCDOE instructional network. Routers, provided by the NYCDOE, will allow these schools to connect to the NYCDOE network, frequently using DMVPNs in order to have full access to all Administrative applications. The school will connect to Internet using service provided by residential or commercial Broadband Internet service providers.

#### Small School Site Deployment

Small School sites have less than 40 users. Typically, they are collocated within non-NYCDOE buildings or properties. This solution is designed for small physical locations where no cable runs are longer than 100 meters. This architecture will support two types of WAN connections to the NYCDOE. If a site has a cable or DSL modem, a DMVPN session can be created to 2 MetroTech. If a site has an EVPL WAN circuit, that circuit is used instead, without the DMVPN session.

Two categories of sites will use this architecture:

- Small School Sites

Some sites have less than 40 users. The Small-School model was created for very small sites such as annex classrooms in hospitals or jails or other very small annex locations. An annex to a school is another example. The Small-School solution supports this scenario. This solution supports all DFS and Administrative applications, instructional traffic with internet filtering, and IPDVS.

- Charter Schools with Full Administrative support

Some charter schools require access to all administrative applications. This solution provides that functionality. If required, this solution can also provide instructional user support with internet filtering.

**Note:** New York City is opening many new locations to provide Universal Pre-Kindergarten (UPK) instruction. The networking standards do not identify any solution specific for UPK sites. These sites should be classified based on their sizes and needed capacity as shown in **Table 6.3** above

### Site Classifications and Standard Network Component Mapping

Along with the above classifications, Tables 6.4 and 6.5, below, align the various school sites with their associated standard component models.

**Table 6.4: Charter-School Sites and Network Component Mapping**

Standard Component	Charter School (DFS & ATS)	Charter school – Full Admin & Service
Router	C1111-8PWB	C8300-2N2S-4T2X
Firewall	(integrated)	None
Core Switch (fiber)	(integrated)	C9500-48Y4C
Core Switch (copper)		MS390-48UX2-HW
Fiber Expansion	None	None
Access Switch	None	MS390-48UX2-HW
Wireless Controller	None	None
Access Point	None	None
Servers	None	None
WAN Optimizer	None	None
WAN Connectivity	DMVPN	EVPL

**Table 6.5: Standard School Sites and Network Component Mapping**

Standard Component	School		
	Small	Medium	Large
WAN Router	C1111-8PWB	Cisco Catalyst 8300	
Firewall	None	None	None
Core Switch (fiber)	None	C9500-48Y4C	
Core Switch (copper)	None	Cisco Meraki MS390-48UX2	
Access Switch	C9300-24P	Cisco Meraki MS390-48UX2	
Wireless Controller	Meraki Dashboard		

<b>Access Point</b>	Cisco Meraki MR57	
<b>Servers</b>	None	Lenovo SR630 (Monitor + Ops needs)
<b>WAN Connectivity</b>	EVPL	

## Room Types

### Instructional and Administrative Rooms

Most Instructional and Administrative Rooms use both data drops and wireless access to connect network devices. As discussed in the [DIIT's Voice/Data Cable Infrastructure Specifications](#) document, the NYCDOE provides six data drops in each classroom of a new building. When additional network devices are included in classrooms, additional data drops may be required.

### District Offices

In some cases, there are administrative employees that work at a school location with Central Domain access. These individuals do not have access to the school network even though their connections are running through the core switch of the school. District Offices use only data drops and do not use wireless access to connect network devices.

### High-Density Rooms

High-Density Rooms are rooms that will host 16 or more network-attached devices (i.e., laptops, printers, servers). Computer labs and libraries are often High-Density Rooms. To allocate resources for these devices properly, we recommend that the LAN switch be mounted in a wall-mounted cabinet within the room. Each computer in a High-Density Room should be connected to a dedicated switch port using Category-6 (see the [DIIT's Voice/Data Cable Infrastructure Specifications](#) document). All data cables must remain out of foot traffic areas and should be placed in cable raceways and secured with Velcro cable ties to allow for workstation additions, moves and changes and for user safety. The LAN switch should have a direct connection to the MDF switch using a Gigabit or Ten Gigabit (If possible) Ethernet Fiber optic port. The indicated configuration results in a four-to-one over-subscription ratio, which is sufficient bandwidth for the maximum number of users in a High-Density Room. Figure 6-1 below shows a typical High-Density Room layout.

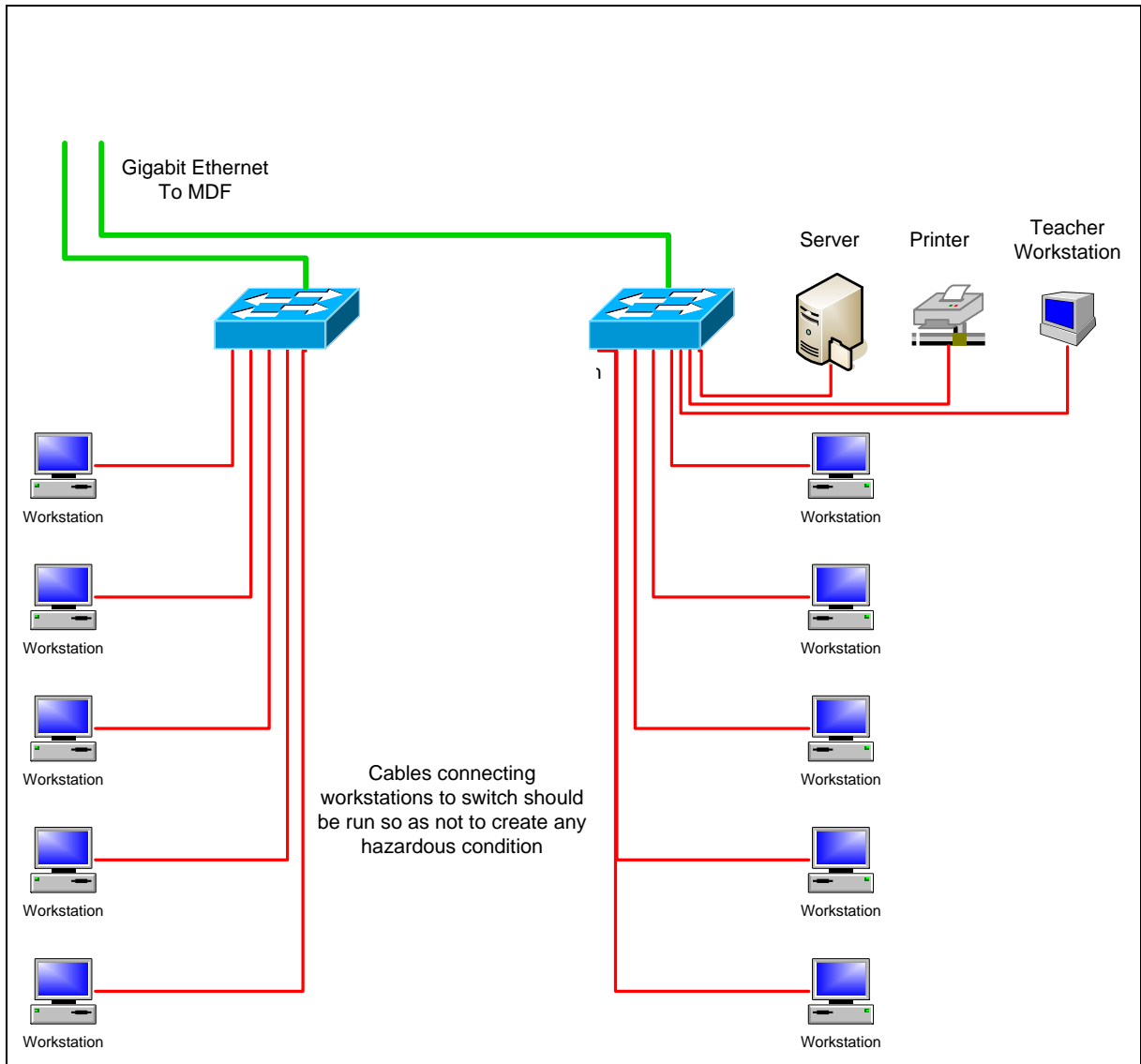

**Figure 6-1: High-Density Rooms**

The fiber runs from High-Density Rooms straight back to the MDF. Typically, 12 strands of fiber (6 pairs) are run to accommodate the 2 lab switches that are deployed for such rooms. Install enough fiber that an additional pair of fiber is available for Day-2 expansion.

In the event that there are more High-Density Rooms than there are fiber runs allotted for that school type, a fiber connection back to the MDF might not be available. If no fiber run is available to connect a High-Density Room, the LAN switch should connect back to the IDF or MDF using Category-6 Ethernet.

#### Other Rooms

In addition to the room types described above, some other room types may require data drops. New school construction or room modifications will dictate the requirements. **Table 6.6** below is a general list provided for informational purposes. DIIT compiled this list through years of collaboration with the School Construction Authority (SCA). Some room types used for Instructional purposes qualify for wireless.

**Table 6.6: Room Type List**

Ascending Order	Room Type
A	Art Room Admin, Art Room Instructional, Assistant Principals Office, Atrium, Auditorium
B	Basement, Boiler Room, Book Room Admin, Book Room Instructional, Boys Bathroom, Boys Locker Room
C	Cafeteria, Classroom, Closet, Computer Lab, Conference Room, Cooking Room, Copy Room, Custodial Help Room, Custodial Office
D	Dance Room, Dean Office, Dentist Office, Dietician Room, District Office, Dressing Room
E	Electrical Room Elevator Room, ESL Room
F	Fan Room, Food Service Office
G	General Office, Girls Bathroom, Girls Locker Room, Guidance Office, Gym Office, Gymnasium
H	Hallway, Holding Room
I	IDF Room
L	Laundry Room, Library, Library Office Admin, Library Office Instructional
M	Mail Room, MDF Room, Multi-Purpose Room Admin, Multi-Purpose Room Instructional, Music Room
N	Nursery, Nurse Office, NYPD Room
O	Office, Other
P	PA Room, Pantry, Parent Coordinator Office, Pool Area, Principal Office, Program Office, Projection Room, PTA Room
R	Resource Room
S	SBST Office, School Store, Science Lab, Science Room Admin, Science Room Instructional, Security Desk, Security Office, Slop Sink Room, Speech Room, Stairwell Room, Storage Room, Supply Room
T	Teachers Bathroom, Teacher's Lounge, Tech Shop Room, Telco Room, Trailer Classroom, Trailer Office
U	UFT Center
V	Vault Room

### ***Hardware Specifications***

#### **Network Components**

Figures 6-2 through 6-10 below briefly describe the capabilities of the technology components that are needed to construct the standard LAN/WAN connectivity infrastructure in support of the NYCDOE schools.

Please see Appendix D for a detailed list of Network Component BOMs.

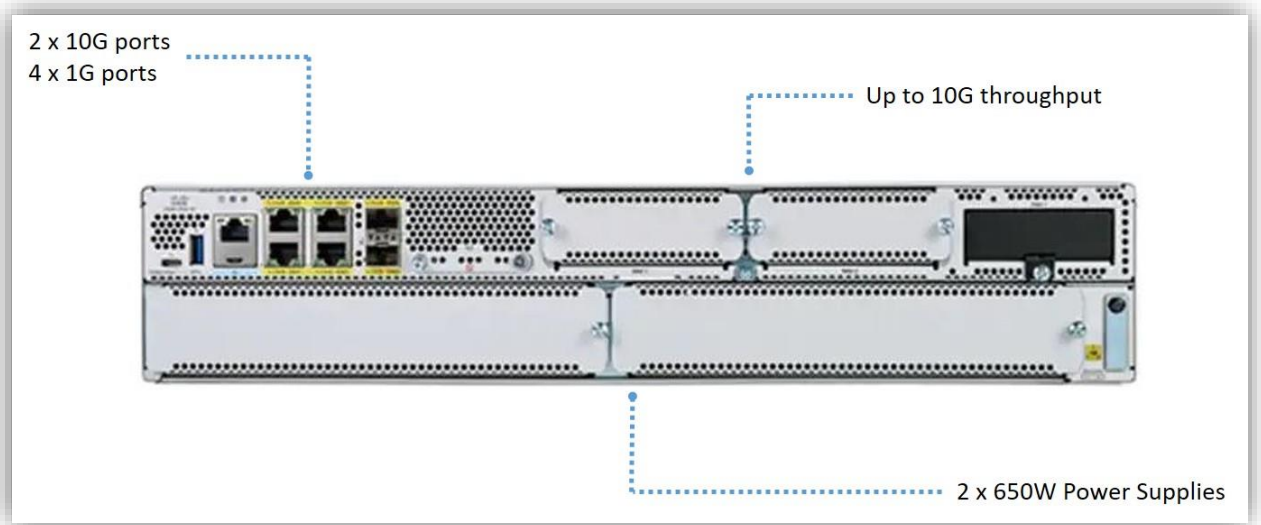

**Figure 6-2: Catalyst 8300 Router WAN connection for Medium/Large Schools**

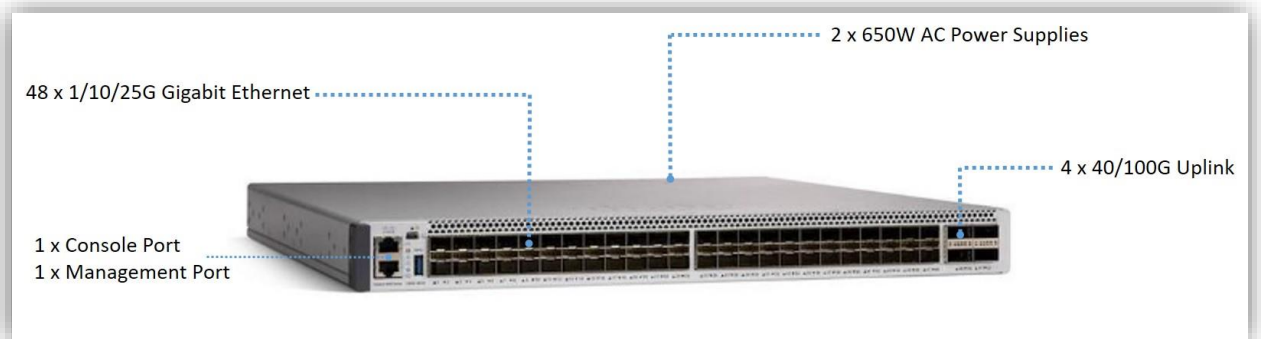

**Figure 6-3: C9500-48Y4C X1 Core Switch for Medium/Large Schools**

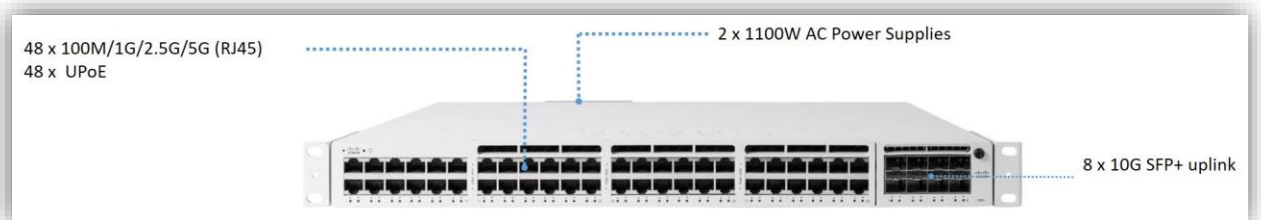

**Figure 6-4: MS390-48UX2 X0 Core Switch for Medium/Large Schools**

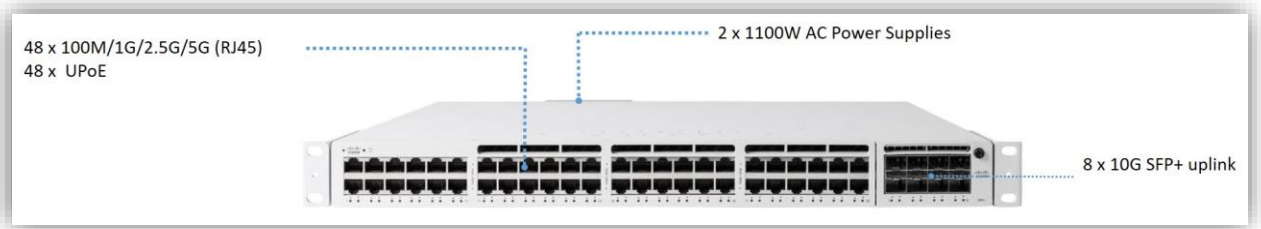

**Figure 6-5: MS390-48UX2 Access Switch for Medium/Large Schools**

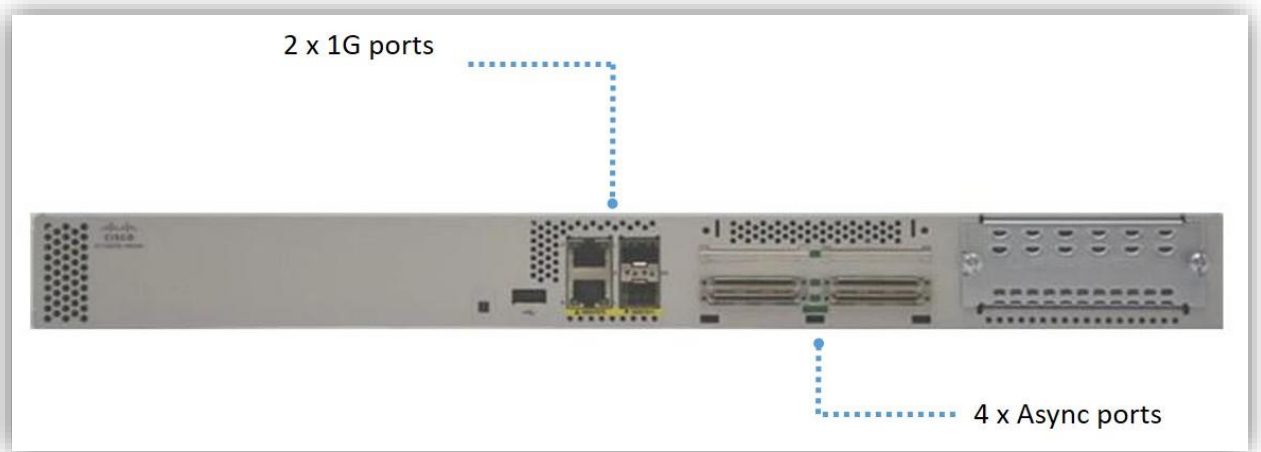

**Figure 6-6: Cisco C1100TG-1N32A Terminal Services Gateway**

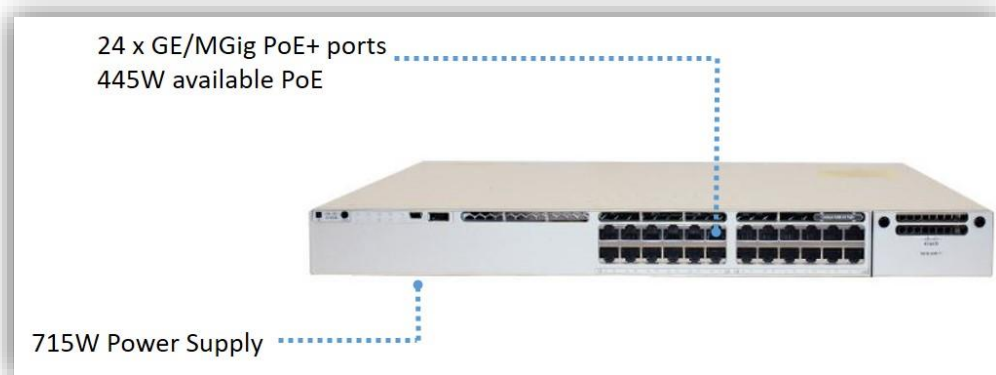

**Figure 6-7: Cisco C9300-24P Access Switch for Small Schools**

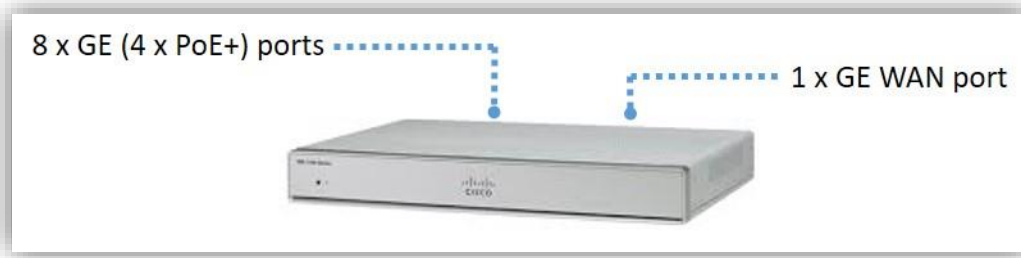

**Figure 6-8: C1111-8PWB WAN Router for Small/Charter Schools**



**Figure 6-9: MR57 Wireless Access Point**

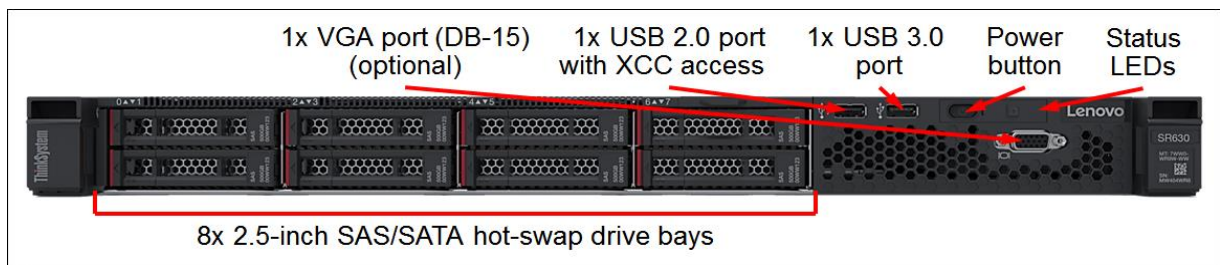

**Figure 6-10: Lenovo SR630 Network Server for Medium/Large Schools**

### **Network Component Details**

The core network components for school sites are the central nerve center for connectivity. It provides both physical and logical connectivity for all attached devices at a given site. Internet connections are facilitated for attached devices to enable them to communicate over the WAN to the Central core backbone at 2 MetroTech. This section summarizes the functions, services and features the core network components provide to each user based on the environment and site classification.

## Implementations for Standard School Sites

Table 6.7 lists the hardware components that Standard School sites uses. Table 6.8 lists the hardware components that Small and Full Admin Charter school sites use. Depending on the school size, network components are housed in at least one, forty-two-unit equipment rack/cabinets installed in the Main Distribution Frame (MDF) room as depicted in **Figures D11** and **D14** below. **Figures D8** describe the Small and Full Admin Charter School site rack/cabinet layout.

**Table 6.7: Hardware Component Summary for Medium and Large Schools**

<b>Component Hardware:</b>	<b>Description:</b>
<b>Patch Panels (Category-6)</b>	Separate 48 Port Patch Panels are provided for voice and data
<b>WAN Router</b>	Cisco C8300-2N2S-4T2X
<b>LAN Core Switch</b>	Cisco C9500-48Y4C-EDU
<b>Service Network</b>	Managed through vManage
<b>Network Infrastructure Server</b>	<p>1U Lenovo SR630 server. The server runs Microsoft Hyper-V.</p> <p>One VM runs Microsoft Windows Server 2019 and provides:</p> <ul style="list-style-type: none"> <li>• DHCP for Instructional clients</li> <li>• WINS</li> <li>• Symantec Updates</li> <li>• SCCM – Device management</li> </ul> <p>A second VM runs Microsoft Windows Server 2019</p> <ul style="list-style-type: none"> <li>• Instructional Network Troubleshooting</li> </ul> <p>A third VM runs Microsoft Windows Server 2019</p> <ul style="list-style-type: none"> <li>• Administrative Network Troubleshooting</li> </ul> <p>A fourth VM runs Red Hat Enterprise Linux (RHEL) 6.5 and provides:</p> <ul style="list-style-type: none"> <li>• Network Monitoring</li> </ul> <p>A fifth VM runs Red Hat Enterprise Linux (RHEL) 6.5 and provides:</p> <ul style="list-style-type: none"> <li>• Network traffic sniffing used for troubleshooting</li> </ul>
<b>Equipment Cabinet</b>	42 Unit (73”) Equipment Rack/Cabinet
<b>Network Surge Arrest</b>	APC Network Surge Arrest

**Table 6.8: Hardware Component Summary for Small Schools.**

<b>Component Hardware:</b>	<b>Description:</b>
<b>Patch Panels (Category-6)</b>	Separate 48 Port Patch Panels are provided for voice and data
<b>LAN Switch</b>	Cisco 9300 24 port switch
<b>WAN Router</b>	ISR 1111
<b>Cable or FIOS MODEM</b>	Depends on Service Provider. Not needed for EVPL

<b>Equipment Cabinet</b>	10 to 13 Unit Equipment Rack/Cabinet
<b>Network Surge Arrest</b>	APC Network Surge Arrest

**Table 6.9: Hardware Component Summary for DFS & ATS-Only Schools**

<b>Component Hardware:</b>	<b>Description:</b>
<b>WAN Router</b>	Cisco ISR 1111 WAN Router
<b>Cable or FIOS MODEM</b>	Depends on Service Provider. Not needed for EVPL
<b>Equipment Cabinet</b>	10 to 13 Unit Equipment Rack/Cabinet
<b>Network Surge Arrest</b>	APC Network Surge Arrest

**Table 6.10: Hardware Component Summary for Full Service Admin & Service Charter Schools**

<b>Component Hardware:</b>	<b>Description:</b>
<b>Patch Panels (Category-6)</b>	Separate 48 Port Patch Panels are provided for voice and data
<b>WAN Router</b>	Cisco C8300-2N2S-4T2X
<b>LAN Core Switch</b>	Cisco C9500-48Y4C-EDU
<b>Firewall</b>	None
<b>Equipment Cabinet</b>	Large enough for all equipment, such as IPDVS if it will be deployed

## **Core Network Component Descriptions**

### Patch Panels

The patch panels provide physical connectivity from the MDF/IDF to desktop locations. (Please see the document, [DIIT Voice/Data Cable Infrastructure Specifications](#), for a full description of both the MDF and the IDF.) Each desktop location is equipped with a category six (Category-6) wiring receptacle. Workstations use a Category-6 patch-cable that extends from the LAN adapter to the local wiring receptacle. The patch panel also provides easy cross-connections to the core network equipment that is housed in the Main Telecommunication Room patch panel rack.

**Note:** There are separate patch panels installed for voice and data, with the voice patch panel installed above the data patch panel.

### Core Switch

The Medium and Large School sites utilize a Cisco C9500 LAN switch/router for the core. It provides Layers 1 - 3 switching and routing, and establish multiple VLANs – Instructional, Admin, Service and District Offices. Clients in the instructional VLAN will have their DHCP requests forwarded to the DHCP server in VLAN 1.

### vManage

The vManage NMS is a centralized network management system that provides a GUI interface to easily monitor, configure, and maintain all routers in the network. Security Group Tags (SGT) are used to control and filter network traffic to and from the school and configured through vManage.

### Network Infrastructure Server

The Classroom Connect communication server, the Lenovo SR630, comes with Microsoft Windows 2012-R2. It provides DHCP, WINS, Symantec Updates and SCCM device management.

### Firewall

The Cisco Firepower 2110 and Firepower 2130 firewalls will no longer be used.

### Out-of-Band (OOB) Router

The Cisco 1100 Terminal Services Gateway provides OOB management. The first three connections go as follows:

1. Catalyst 8300
2. 9500 core switch

These configurations should not be changed. Starting with the fourth connection, changes are allowed depending on the equipment being installed at the school.

## **Core Network Component Services**

In conjunction with the **Network Services** described above, the standard core network components (as described in Table 6.11 below) provide the essential alignment of network services such as: Internet access, subnet routing, enhanced security services, DHCP, proxy services for content filtering and caching and remote SNMP device monitoring. Table 6.11 summarizes the services provided, aligned by site classifications.

**Table 6.11: Core Network Component Services Summary**

<b>Core Network Component Services</b>	<b>Functional Description</b>	<b>(Medium, and Large) &amp; Full Admin</b>	<b>Charter School Site (DFS &amp; ATS)</b>	<b>Small School</b>
<b>Enhanced Security</b>	Defines the use of SGTs for inter-site security.	Provided by Cisco Meraki Cloud Services	N/A	Provided by the ISR 1111 Router
<b>Instructional DHCP Services</b>	Defines dynamic IP address assignment with uniform policy options established for each client subnet.	Provided by the Lenovo SR630, Network Infrastructure Server. No instructional network for Charter School	N/A	Provided by the ISR 1111 Router

<b>Administrative and Service DHCP Services</b>	Defines dynamic IP address assignment with uniform policy options established for each client subnet.	Provided by the 9500 Switch, for Medium, Large and Full Admin Charter schools	N/A	Provided by the ISR 1111 Router
<b>Administrative Devices</b>	Administrative SGTs	Provided by SGTs	Provided by the ISR 1111 Router	Provided by the ISR 1111 Router
<b>Remote Monitoring</b>	Defines the SNMP system management functions for the remote site	NOC Management & Monitoring Tools	NOC Management & Monitoring Tools	NOC Management & Monitoring Tools
<b>Subnet Routing and Switching</b>	Local LAN routing and forwarding	Switching and IP Routing between VLANs performed by 9500.	N/A	Provided by the ISR 1111 Router
<b>Service / IoT Devices</b>	Network used by services such as IPDVS, POS & CAASS	Provided by C9500	N/A	N/A

### **Connectivity Infrastructure**

There are several basic components to school connectivity:

1. **The Physical Connectivity Infrastructure:** The electrical and optical cabling within a school that provides physical connectivity for various network components. [DIIT's Voice/Data Cable Infrastructure Specifications](#) covers this topic in detail.
2. **The WAN Connectivity Infrastructure:** The networking equipment providing the school with communications to the Wide Area Network. The WAN is used to provide Internet access and access to Central NYCDOE resources. Most of this equipment is located in a single Main Distribution Frame (MDF) rack/cabinet.
3. **The LAN Connectivity Infrastructure:** The networking equipment providing communications among devices within the school. LAN equipment is located partly in the MDF room and partly in Intermediate Distribution Frame (IDFs) rooms located throughout the school and connected to a central X1 switch in the MDF.

Please note that multiple technology areas must be planned and reviewed before construction can be performed at either a new or an existing site. Each technology area carrier has its own comprehensive list of components that are required to provide the needed functionality. When construction to an existing structure is planned, a checklist of components is required. The entire suite of components must be selected based on the site classification the school will be assigned when a new site is constructed from the ground up.

## **Physical Connectivity Infrastructure**

Figure 2.1, taken from the “[DIIT Voice/Data Cable Infrastructure Specifications](#)” in Section 2, shows a high level view of the physical infrastructure within a school building. Horizontal CAT 6 cabling on each floor connects end user devices (computers, printers, etc.) with switches in IDFs. The IDF switches connect to the MDF switch using multi-mode fiber optic cables. CAT6 Voice connections between telephones on each floor and a PBX (usually located in the MDF) are also provided.

### DEMARC is far from MDF

The standard school WAN connection is EVPL. However, there are times that the MDF is too far from the Point of Demarcation (POD) or DEMARC. Copper Ethernet cables have a maximum length of 100 meters. If the DEMARC is further than 100 meters from where the WAN circuit should terminate, then it cannot be connected via copper. Fiber must be used instead.

This situation should be temporary. It usually occurs when we move the MDF to a new room. To remedy the situation, the ISP should move the DEMARC to the MDF. However, we still need to provide WAN connectivity until the DEMARC is moved. For a temporary solution, we deploy a Cisco router in the room with the DEMARC. We run copper from the DEMARC to the router. We utilize fiber from the router to the core C9500 in the MDF. This connection is 10Gbps using matching multimode SFPs at each end. The core switch configuration needs to change.

The standard fiber runs are now 50 micron (using OM3 and OM4), however, we can use older 62.5-micron fiber for distances up to 275 meters if we have not yet installed the 50-micron fiber. After the DEMARC is moved, the network is configured as per normal standards.

## **LAN / WAN Connectivity Infrastructure for Standard Schools**

The LAN & WAN infrastructure is a standard set of equipment and services that provide schools, annexes, and Regional Learning Centers with connectivity to the Internet. The same network provides connectivity to instructional support applications throughout the Central NYCDOE computer facility, located at 2 MetroTech Center (2MTC) and also at a secondary data center. Figure 6-10 below is a high-level representation of the LAN & WAN infrastructure for Standard Schools (i.e.; Small, Medium, and Large).

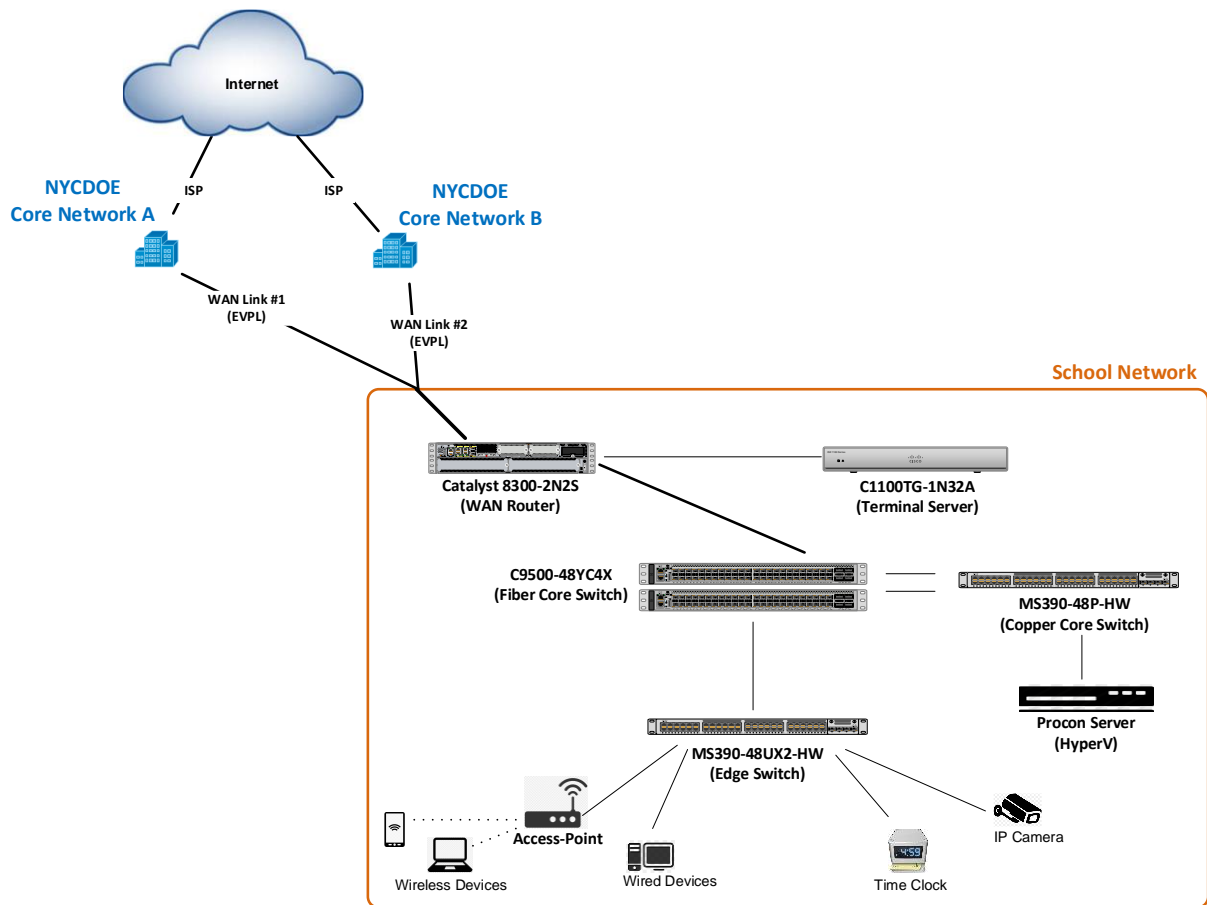

**Figure 6-11: Standard Schools LAN & WAN Connectivity**

### LAN / WAN Connectivity Infrastructure for DFS & ATS Charter Schools

For DFS & ATS Charter Schools, the NYCDOE provides a specific set of LAN equipment, as shown at a high level in Figure 6-11 below. Specifically, Charter School use a Cisco ISR 1111 to enable DFS printing via VPN. Every Charter School must obtain its own Internet service/ISP. Once this is in place, the other requirements are as follows:

- Router obtains an IP address from the local DHCP server for the Charter School network. The router uses TCP port 443 for the VPN tunnel traffic.
- The VPN IP address is to the NYCDOE.
- The DFS printer(s) require one or more data connection to the school's network is needed in the room where they are located. The printer connects to a LAN port on the router that connects via its WAN port to the school's ISP network to enable DFS printing and other administrative applications via VPN tunnel.
- Router requires an Ethernet connection to the Charter School network. Some schools use wireless for Web Connect.

**Note:** Some Charter Schools have independent locations. Others share space in NYCDOE schools. Regardless of location, we must adhere to all of the above criteria. Specifically, it is not allowed to connect Charter Schools to NYCDOE school network infrastructure.

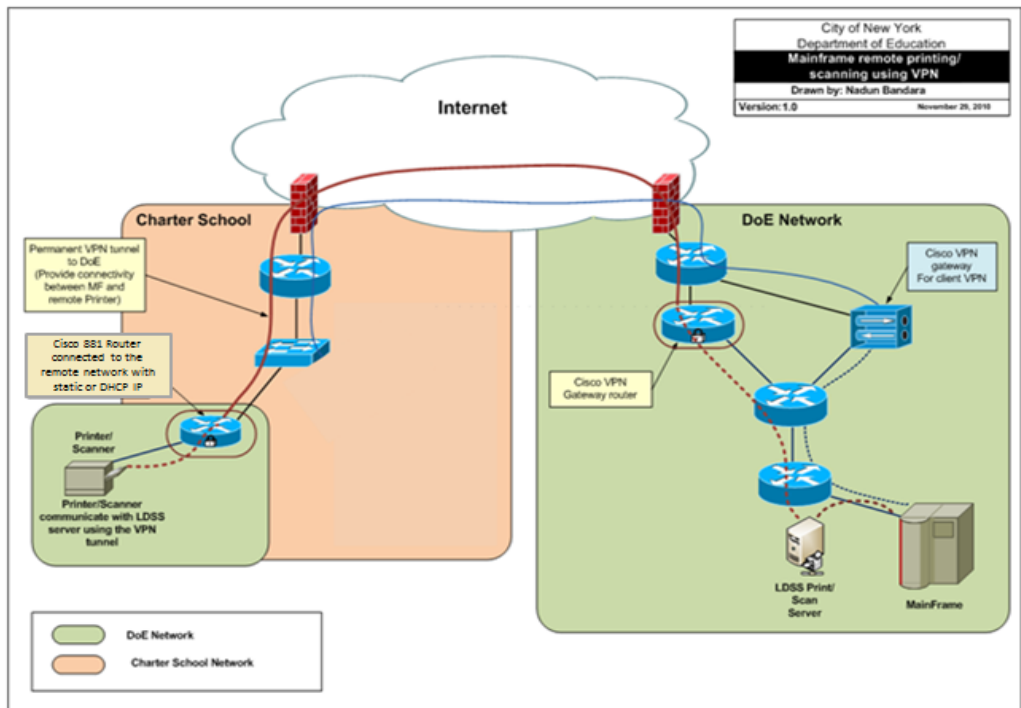
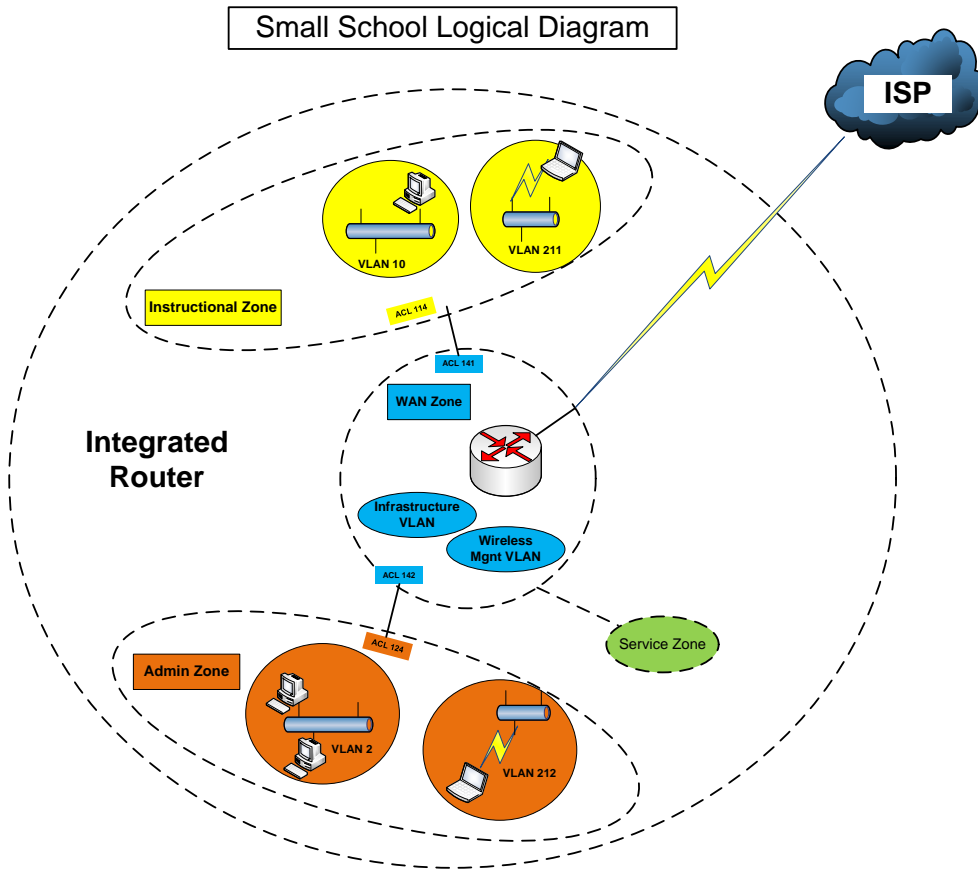

**Figure 6-12: DFS & ATS Charter School LAN & WAN Connectivity**

**LAN / WAN Connectivity Infrastructure for Small Schools & Full Admin Charter Schools**

Like the Medium and Large Schools, Small Schools must have connectivity to applications that reside at the 2 MetroTech data center or the ROCs. This solution requires internet connectivity via Cable or FIOS services, or EVPL WAN connection.

Figure 6-12 below is a high-level representation of the LAN & WAN infrastructure at Small Schools and Full Admin Charter Schools.



**Figure 6-13: Small Schools LAN & WAN Connectivity**

### Full Admin and Service Charter School Standards

Full Admin and Service Charter Schools have a standard network design. This design supports full administrative and service network functions. As with other charter schools, instructional network access is not permitted.

To accomplish these goals, DIIT based the design on the previously standard Small-School standard network design. This standard uses the exact same hardware as the no-longer-used small school. The core switch is the C9500-48Y4C-EDU. User ports are connected to MS390-48UX2-HW Layer 2 switches.

DIIT based the configurations on the standard configurations. The difference is that the instructional networking functionality is disabled.

## ***Local Area Network Connectivity***

Within every school building, there is a Local Area Network (LAN). The LAN is what connects all of the network devices at a location. These devices include end-user devices as well as network infrastructure devices. The end-user devices include PCs, printers, and wireless devices. The infrastructure devices include switches, servers, routers, and access points.

This section describes the architecture of the Local Area Network's physical and logical characteristics.

### Physical LAN Topology

Every site has a core switch that defines and manages the network functionality for the site. Other switches connect to this core switch. These additional switches are referred to as edge switches. The other end-user devices connect to these edge switches. The switches connect via fiber while the wired end-user devices use copper patch cords or wireless signal.

Fiber connects the switches for two primary reasons: greater distance and greater bandwidth. The core switch is located in a room called the MDF (Main Distribution Frame). The other rooms with fiber-connected switches are called Intermediary Distribution Frames (IDFs).

Other devices such as PCs, printers, and access points connect to the IDF switches. Please note that a room can provide the functionality of both an MDF and an IDF. In this case, it is usually referred to as the MDF.

The edge switches connect from the IDFs to the core switch in the MDF at 10Gbps using 50/125 $\mu$ m fiber as specified in the cabling section. Each switch connects using one pair of 50/125 $\mu$ m fiber with an SFP+ at either end. The SFP+ converts the optical signal to an electrical signal.

Each edge switch in an IDF connects to the core switch using its own pair of fiber strands. To provide sufficient fiber capacity to each IDF, trunks of 24 strands are run. If additional fiber capacity is anticipated, additional trunks are pulled, as needed.

**Note:** The only difference in equipment models between Medium and Large schools is the performance license for the Cisco 8300 router. The standard core switch is the Cisco C9500-48Y4C-EDU

### Virtual Routers (Instructional, Administrative, and Service)

The LAN at each site is divided into three virtual segments. The reason for this segmentation is to ensure that network traffic for students and teachers (instructional) is kept isolated from sensitive administrative network traffic and traffic used for services such as digital surveillance, cafeteria point-of-sale, and environmental monitoring and controlling. Table 6.12 highlights the LAN Topology Configuration for Standard Schools.

**Table 6.12: LAN Topology Configuration**

MDF Core / Cabinet Description	Trunk Connectivity	IDF / Cabinet Description
<p>Topology:</p> <ul style="list-style-type: none"> <li>• Star</li> </ul> <p>Physical Connectivity:</p> <ul style="list-style-type: none"> <li>• Multi-mode Fiber (Trunks) to switches</li> <li>• Category-6 to Access Points, Workstations/Servers</li> </ul> <p>LAN Transport:</p> <ul style="list-style-type: none"> <li>• 10 Gig-Ethernet Trunks to IDF</li> </ul> <p>Cabinet Equipment:</p> <ul style="list-style-type: none"> <li>• C9500-48Y</li> <li>• Meraki MS390 Switch **</li> <li>• Network Infrastructure Servers</li> </ul> <p>* All physical connections collapse into a central C9500-48Y4C-EDU switch located in the MDF.</p> <p>** The MS390 is used for additional copper switch port capacity.</p>	<p>Physical Connectivity:</p> <ul style="list-style-type: none"> <li>• 50/125 micron multi-mode fiber</li> </ul> <p>LAN Transport:</p> <ul style="list-style-type: none"> <li>• 10 Gig Ethernet (Trunk)</li> </ul>	<p>Topology:</p> <ul style="list-style-type: none"> <li>• Point-to-Point (IDF to MDF)</li> <li>• Star (IDF to Classrooms)</li> </ul> <p>Physical Connectivity:</p> <ul style="list-style-type: none"> <li>• 50/125µm Multi-Mode Fiber (Trunks)</li> <li>• Category-6 (classroom drops)</li> </ul> <p>Cabinet Equipment:</p> <ul style="list-style-type: none"> <li>• Patch Panels</li> </ul> <p>Meraki MS390 Switch - This is an optional intermediate facility.</p>

**Wide Area Network Connectivity**

Excluding Small and Charter Schools, DIIT provides all school sites with Internet access primarily through a Metro Ethernet network. Each new school is provisioned with a Metro Ethernet circuit. The speed can vary depending on the size of the site. Any non-NYCDOE networked site that needs Mainframe printing and scanning is given a Point-to-Point VPN solution and the users use WebConnect.

Use of Metro Ethernet Services

Newly constructed schools use Metro Ethernet, EVPL services as the standard WAN connection type. Metro Ethernet provides a high bandwidth, low cost alternative for WAN connectivity, where it is available. There is no logical separation of network traffic for instructional and administrative traffic. All network traffic (i.e., Internet, etc.) will share the dedicated EVPL circuit.

Backup Connectivity

The standard school WAN connection is EVPL. However, there are times that an EVPL connection is unavailable. This scenario occurs most often under two circumstances:

1. For a new school, the Internet Service Provider (ISP) has not yet run fiber to the building
2. The existing fiber from the ISP has been damaged

To provide connectivity when EVPL is not available, a VPN solution is used. A broadband circuit such as cable modem is used. We connect the school router to the cable modem. We configure a VPN connection

from the router to the DOE. We continue using this VPN connection until the EVPL circuit is available at which time we cut over to using the EVPL instead

### Use of Broadband Services

Small and Charter Schools are usually provided WAN access through Broadband services such as Cable Modem or FIOS connection types. Small Schools and Full-Admin Charter Schools may sometimes have EVPL, instead. Unlike EVPL, which is a “symmetrical” service, Broadband services are typically “asymmetrical” providing greater “download” speeds than “upload”. For example, standard Cable Modem services typically provide “download” speeds that max out around 15Mbps with top “upload” speeds near 1Mbps. Therefore, when ordering Broadband services, **Business Class** would be recommended in order to get the same “download and upload” speeds.

**Note:** We recommend that the schools purchase five static IP addresses.

### Central Core Router Connectivity

The Central core routers located at 2 data centers of the NYC DOE via fiber throughout the 5 boroughs provide Wide Area Network connectivity to over 1800 schools and 1300 buildings. WAN links from each school connect to Crown Castle facilities, which aggregate traffic and connect to Central core routers utilizing Ten Gigabit Ethernet links. Each Ten Gigabit Ethernet link supports 30 Primary and 30 backup school circuits. Routing protocols control communication between the remote site router and the Central computing facility. The remote site router sends routing updates to the Central core router and the core routers send a default route to the remote site routers.

### Circuit Installation and Demarcation Boundary

The telecommunication service provider is responsible for terminating the WAN data circuits in the Main Telecommunications Room or Classroom Connect MDF. Extended demarks are no longer recommended.

### WAN Circuit Orders and Billing

The Division of Instructional and Information Technology (DIIT) is responsible for releasing all WAN circuit orders to the appropriate telecommunication service providers and will assume all installation responsibilities and expenses associated with the installation and operation of the circuits.

For new brick-and-mortar construction, circuit orders are placed as part of the new school construction process and are coordinated between the NYC School Construction Authority (SCA) and the QA and Engineering Support Group.

To request a bandwidth upgrade to existing circuits, schools should call the Service Desk (718-935-5100). Network Operations Center (NOC) staff performs a technical investigation to determine that a higher bandwidth WAN link is required to meet the schools bandwidth needs.

## ***Network Addressing and VLAN Designation***

Within each school, different communities use a common Local Area Network. For obvious reasons, the information administrators interact with must not be accessible to students. DIIT separates traffic within the school LAN logically, using a set of Virtual LANs (VLANs), assigned to different organizations in the

school. Over time, new services deployed in schools have caused the number of VLANs to expand. The function of VLANs in NYCDOE schools is to logically separate traffic. Limiting the number of devices on a network improves its performance.

### Current VLAN Designation

Networks and services being used in the schools of the NYC DOE are mostly managed through the cloud. Some of them are managed through Cisco vManage. It is a highly customizable dashboard that simplifies and automates the deployment, configuration, management, and operation of Cisco SD-WAN. Other services are managed through the Meraki Dashboard. Security and filtering will be controlled remotely which eliminates the need for a firewall at the school. Table 6.13 shows the VLAN designation used for each school using the current network design.

**Table 6.13: VLAN & SGT Designations**

VLANs	Use	SGT
VLAN 1	APs, Switches, etc	INFRASTRUCTURE
VLAN 1	Servers	INFRA_SERVERS_LOCAL
Port Channels	Trunk	AGGREGATION
VLAN 2	Admin Access	ADMIN
VLAN 2	Nurses	HEALTHCARE
VLAN 211	User Access (wired and wireless)	INSTRUCTIONAL
VLAN 260	Guest	DOE_GUEST
VLAN 411	IoT Devices with Internet Access	IOT_CLOUD
VLAN 412	IoT Devices without Internet Access	IOT_NO_CLOUD
VLAN 412	IPDVS	IOT_IPDVS
VLAN 501	Voice / Collaboration	VOIP_LOCAL
VLAN 991	District Office	DISTRICT_OFFICE

**Note:**

**IoT Devices with Internet Access include: WTMC, ACEUM, Lonworks, POS, Dashboard, CAASS, EUM, Cybershift clocks**

**IoT Devices without Internet Access include: Wall Clocks, Bells, PA systems**

**Table 6.14: Mapping Old VLAN to new VLAN and SGTs**

Old VLAN	Description	New VLAN	SGT Name	Peer-to-Peer Communication	Notes
Trunk	Port Channel	Trunk	Aggregation	N/A	MS390 (X0) to 9500 (X1)
Trunk	Access Point	Trunk	Infrastructure	Yes	
1	Management + Infrastructure	1	Infra_Servers_Local	Yes	For Servers
1	Management + Infrastructure	1	Infrastructure	Yes	Switches (use a trunk)
2	Admin	2	Admin	Yes	Admin Users
2	Nurses	2	Healthcare		Access Printers
3	Outside Transit	N/A	N/A	N/A	No longer used
5	Server IMM	N/A	N/A	N/A	IMM connects to C1111
10	Instructional Wired	211	Instructional	Yes	
20	Instructional Wired	211	Instructional	Yes	
21	Admin	2	Admin	Yes	
27	Admin Transit	N/A	N/A	N/A	No longer used
30	Instructional Wired	211	Instructional	Yes	
40	Instructional Wired	211	Instructional	Yes	
50	Instructional Wired	211	Instructional	Yes	
60	Instructional Wired	211	Instructional	Yes	
70	Instructional Wired	211	Instructional	Yes	
80	Instructional Wired	211	Instructional	Yes	
90	Instructional Wired	211	Instructional	Yes	
100	AP Management	1	Infrastructure	Yes	APs use a Trunk (Native VLAN 1)
110	Instructional Wired	211	Instructional	Yes	
200	Firewall Management	1	Infra_Servers_Local	Yes	
211	Instructional Wireless	211	Instructional	Yes	
260	Guest	260	DOE_Guest	No	
400	IoT (Service) Transit	N/A	N/A	N/A	No longer used
410	LonWorks	411	IoT_Cloud	Yes	
411	WTMC	411	IoT_Cloud	Yes	
412	ACEUM	411	IoT_Cloud	Yes	
413	Dashboard	411	IoT_Cloud	Yes	

415	AC Management	411	IoT_Cloud	No	
420	CAASS	411	IoT_Cloud	Yes	
430	POS	412	IoT_no_Cloud	Yes	All other POS
430	POS	411	Food_Manager	Yes	Dietician's PC
440	Wall Clocks, Bells, PA	412	IoT_no_Cloud	Yes	
445	ESX INS	N/A	N/A	N/A	No longer used
446	ESX Admin	N/A	N/A	N/A	No longer used
447	ESX Shared	1	Infra_Servers_Local	Yes	
460	EUM	411	IoT_Cloud	Yes	
470	IPDVS	412	IoT_IPDVS	Yes	
480	Timeclocks (Cybershift)	411	IoT_Cloud	No	
501	Voice	501	VoIP_Local	Yes	
600	RSPAN	N/A	N/A	N/A	No longer used
990	District Office Transit	N/A	N/A	N/A	No longer used
991	District Office	991	District_Office	Yes	

## Services

DIIT designed network hardware in the MDF and IDF to provide a set of services supporting LAN/WAN functionality. These include the following.

### DNS

Domain Name Systems (DNS) for the Internet translate a hostname (i.e.; schools.nyc.gov) to an IP address.

### DHCP

Dynamic Host Configuration Protocol (DHCP) defines dynamic IP address assignment, via a server or network device (i.e.; router or switch), with uniform policy options established for each client subnet.

### Wireless

A spectrum based transmission method that supports the communications of mobile computer devices (i.e.; laptops, tablets, smart phones) throughout the NYCDOE schools to network resources via the 802.11a/g/n/ac/ax and WiFi wireless network connectivity standards.

### AD

Active Directory (AD) is a Microsoft directory service for Windows domain systems and computer devices. The school is responsible for managing their own AD without the support of the Server Operations team.

### Network Management Services

NYCDOE/DIIT has established a Network Operations Center (NOC) at 2 MetroTech Center in downtown Brooklyn. The NOC uses multiple tools and procedures in a proactive approach for the detection of potential IT infrastructure failures enterprise-wide. Its variety and combination of monitoring programs helps to ensure strict and redundant monitoring of all IT infrastructure resources and facilitates both immediate and appropriate action by NOC personnel. Network analysts, specialists and engineers able to assist with all critical IT infrastructure issues work in the NOC. Some technical details may be found below while a more comprehensive description may be referenced in the [Network Operations Center Policies and Procedures](#) document.

- Remote Network Monitoring (RMON) is a method of collecting and analyzing information from remote network devices. An RMON agent attached to a local network device captures information and statistics on protocols and traffic activity and communicates the information back to a central RMON management station, located in the NOC. RMON probes and RMON agents provide this information when polled by the central management station. RMON probes can provide a great deal of information on the performance of the LAN and WAN. Furthermore protocols such as SNMP, SSH and ICMP are used to analyze remote network devices.

### AD and DNS Association

DIIT recognizes the need for schools to provide a measure of authentication, resource sharing and control to their users. The schools sometimes use AD and DNS for authentication in the schools.

### Centralized Content Filtering (http and https)

There are currently different approaches to content filtering for Instructional, Administrative and Central LANs. Instructional users include those accessing the Internet from student classrooms and libraries. Their filtering complies with CIPA and provides additional filtering at the school's request, which may be more or less restrictive. Users working on the Administrative and Central LANs have a set policy that filters only adult content and security related websites.

Schools (Instructional LANs) may request changes to their filtering categories by submitting a request to the following website: <http://nycboe.net/Applications/Filtering>.

Note: This website is only accessible from the Administrative LANs in each school. The principal or principal's designee must approve the request.

Table 6.21 below summarizes the Network Services provided at the NYCDOE with functional details.

**Table 6.15: Network Services**

<b>Network Services:</b>	<b>Functional Description:</b>	<b>Local Equipment Suite Required:</b>	<b>Special Configuration Changes Required:</b>	<b>Remote Core Backbone Services Required:</b>
<b>WAN Security</b>	Defines the use of an SGT for inter-site security.	Local Site: SGTs		N/A
<b>Guest/BYOD DHCP Services</b>	Defines dynamic IP address assignment with uniform policy options established for each client subnet.	Core X1 switch		
<b>Instructional DHCP Services</b>	Defines dynamic IP address assignment with uniform policy options established for each client subnet.	Local Site: Network Infrastructure Server	N/A	N/A
<b>DNS Services</b>	Translates Fully Qualified Domain Names to IP addresses.	None		
<b>Network Management Services</b>	Packet capture and analysis. SNMP Monitoring			NOC monitoring tools
<b>Subnet Routing and Switching</b>	Local LAN routing and forwarding of IP between VLANs.	Core X1 Switch	N/A	N/A

### **Application Services**

In addition to Network Services, the network supports a number of applications deployed at schools throughout the NYCDOE. Please note that not all of the following are deployed at all schools.

#### LonWorks

LonWorks is a graphical user interface (and service network application) which allows on-line custodial control of the heating and cooling equipment for many buildings (boiler and HVAC, respectively). If the need should arise, authorized personnel at Central can remotely override this custodial control. A standards manual for LonWorks resides on SharePoint, along with those of other service network applications, such as CAASS and IPDVS.

#### CAASS

CAASS (Comprehensive Attendance Administration Security System) is a software/hardware system that uses smart cards to monitor a student's entry at schools. Each school entrance has hardware so students can swipe smart cards as they enter. Updates are pushed to the software used by this system daily so that the student rosters are current, guaranteeing that only students enrolled in a school can enter freely.

The most recent revision to CAASS enables web-based access of information from the system through the Internet. The previous version of CAASS, installed in more than 200 schools, uses the school LAN for communication between hardware at entrances and a dedicated school-based server with updates provided by manual downloads from ATS. All new CAASS installations will use the web-based version. Schools that already have CAASS will be eligible for an upgrade after five years.

Network connectivity for CAASS will be hardwired only. It is not meant for wireless connections. The designated network for this service is VLAN 411 (see table D3 for IP address details).

### POS

POS (Point of Service) is an application that allows students to use smart cards to pay for food in school cafeterias. The smart cards allow any automatic adjustments to the amount students pay for their meals based on information stored in the POS computers. Parents can pre-pay into an account using on-line transfers, with the price of their children's cafeteria purchases automatically deducted. This system makes the process simpler for the parents. Students do not need to have money with them in order to get school lunches.

- Point of Sale (POS) System: The system provides a data outlet and a duplex, dedicated 20 Amp, 120 Volt receptacle for each of the POS Stations in the Student's Servery and the Teacher's Servery. The design places POS Station data outlet and receptacle at the beginning and the end of each of the serving lines in the Servery. For High Schools only, the design also places a data outlet and a duplex, dedicated 20 Amp, 120 Volt receptacle near the main building entrance. In the student cafeteria at the Primary, Intermediate, Junior and High Schools, dedicated data outlets and duplex 20 Amp, 120 Volt receptacles shall be provided for each POS Kiosk as follows:

# of Student	# of POS Kiosk
1 – 750	1
751 – 1500	2
1501 and more	3

### IPDVS

IP Digital Video Surveillance (IPDVS) is a project that places cameras at strategic locations in schools, providing video feeds on demand from control centers at the school or at other strategic locations. It allows remote monitoring of school facilities as part of an effort to enhance school safety. Videos are archived and are occasionally referred to when incidents at schools are investigated.

### EUM

Electrical Utilization Monitoring (EUM) allows the schools to monitor electrical usage.

### Time clocks

Used for DOE staff to clock in and out using a designated badge.



## **Appendix A – School Cable Infrastructure**

---

### ***Asbestos Testing and Protocol***

To protect students, school personnel and contractors from accidental exposure to asbestos, the following procedures will be followed:

- 1) The Contractor and DIIT project manager will review AHERA report prior to commencement of work in a school.
- 2) If AHERA report is positive for ACM on surfaces that will be penetrated, the following steps will be taken:
  - a) An alternative cabling route avoiding ACM surfaces will be found.
  - b) If ACM material is so pervasive that a reasonable alternate route cannot be found then, the Department project manager will recommend and pursue the installation for special handling.
- 3) If during the course of the installation the original cable route/design is modified, the Department project manager must be notified and the AHERA report referenced again for ACM.

Please see the DSF Asbestos Compliance (AHERA) rules, at:

<http://www.opt-osfns.org/dsf/vendors/vendorstools.aspx>

HEALTH AND SAFETY **MUST** BE NOTIFIED OF **ALL** CABLE ROUTES, REGARDLESS OF AHERA FINDINGS.

### ***Lockbox Specifications***

The lockbox must be a painted, 16-gauge metallic enclosure. The lockbox door shall have a key lock installed so that a key is required to open and close the door. External mount lockbox (see APPENDIX 2-B and 2-C) or semi-recessed lockbox (Sub Appendix 2-D) will house wall mount phones. Exceptions to this standard must be discussed between SCA, Contractor(s) and DIIT prior to installations. New construction sites will use lock box with the flange only.

The lockbox shall be provided with means to connect a modular ITT 2554-type wall telephone. The phone itself shall be secured with a screw through the back plate (chassis) into the jack assembly and the lockbox.

External lockbox (see APPENDIX 2-B and 2-C) must have knockouts - three on top and three on bottom - to accept Wiremold type V-700 raceway. Proper lockbox/raceway interface hardware must be used to prevent tampering with the cables.

Two (2) keys shall be provided with each lockbox and distributed as previously specified. All boxes are to be keyed alike.

Lockboxes will be mounted so that the center of the phone, when installed, is 48" inches from the floor.

Lockboxes shall be installed away from high traffic areas. No lockbox shall be mounted within six (6) inches of any hall or closet edge in high traffic areas. Exact location of lockboxes shall be determined during a site survey with the DIIT and SCA project managers and/or Contractor, and/or a designated School/site representative.

The following is acceptable for mounting lockboxes: Toggle Bolts - Molloy Bolts - Lead Anchors.

**SUB-Appendices 1(A) – 1(D)**

Category 6 Wall Phone Faceplate with Keystone Module for Lockbox

**Lockbox without Flange**

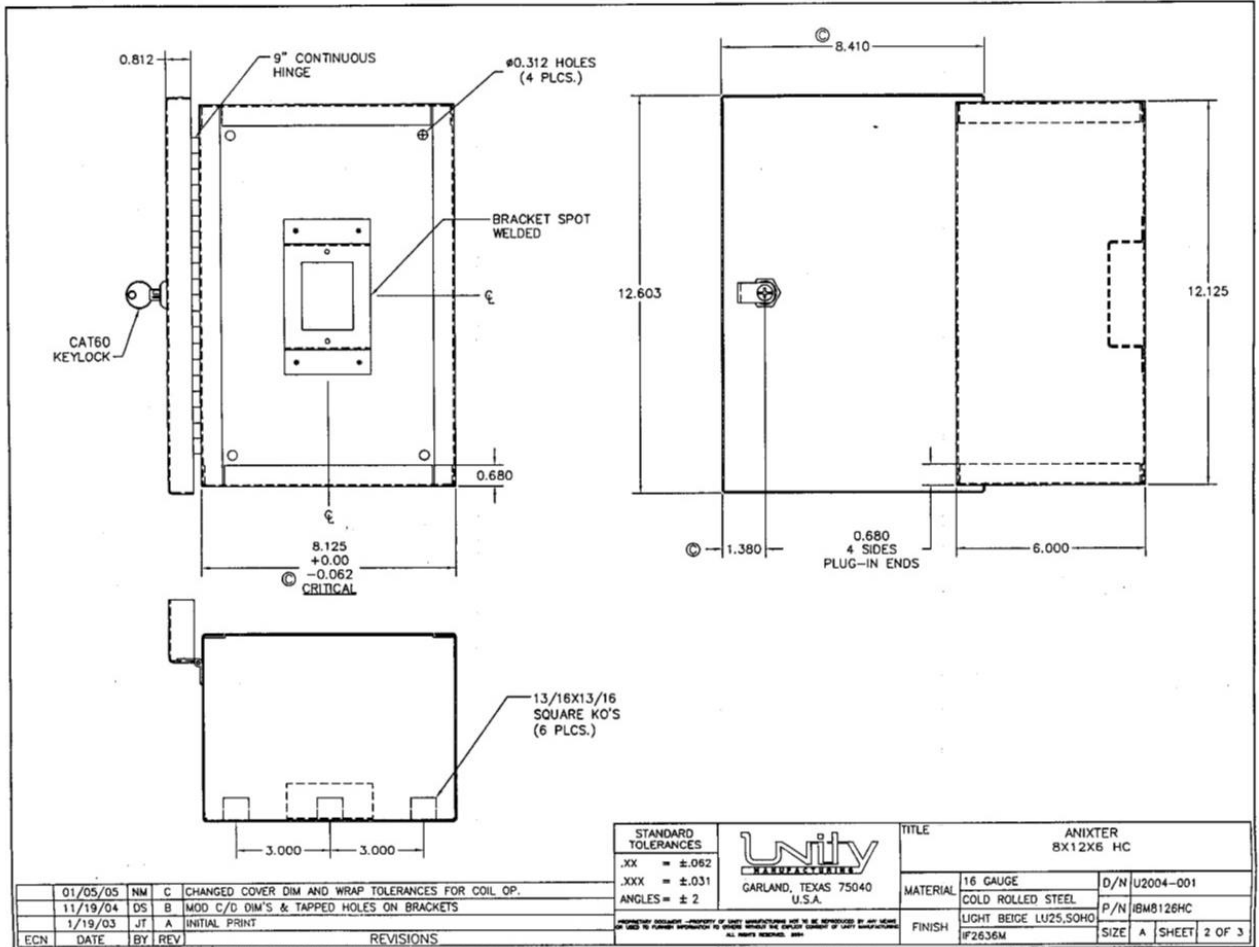

# Lockbox without Flange

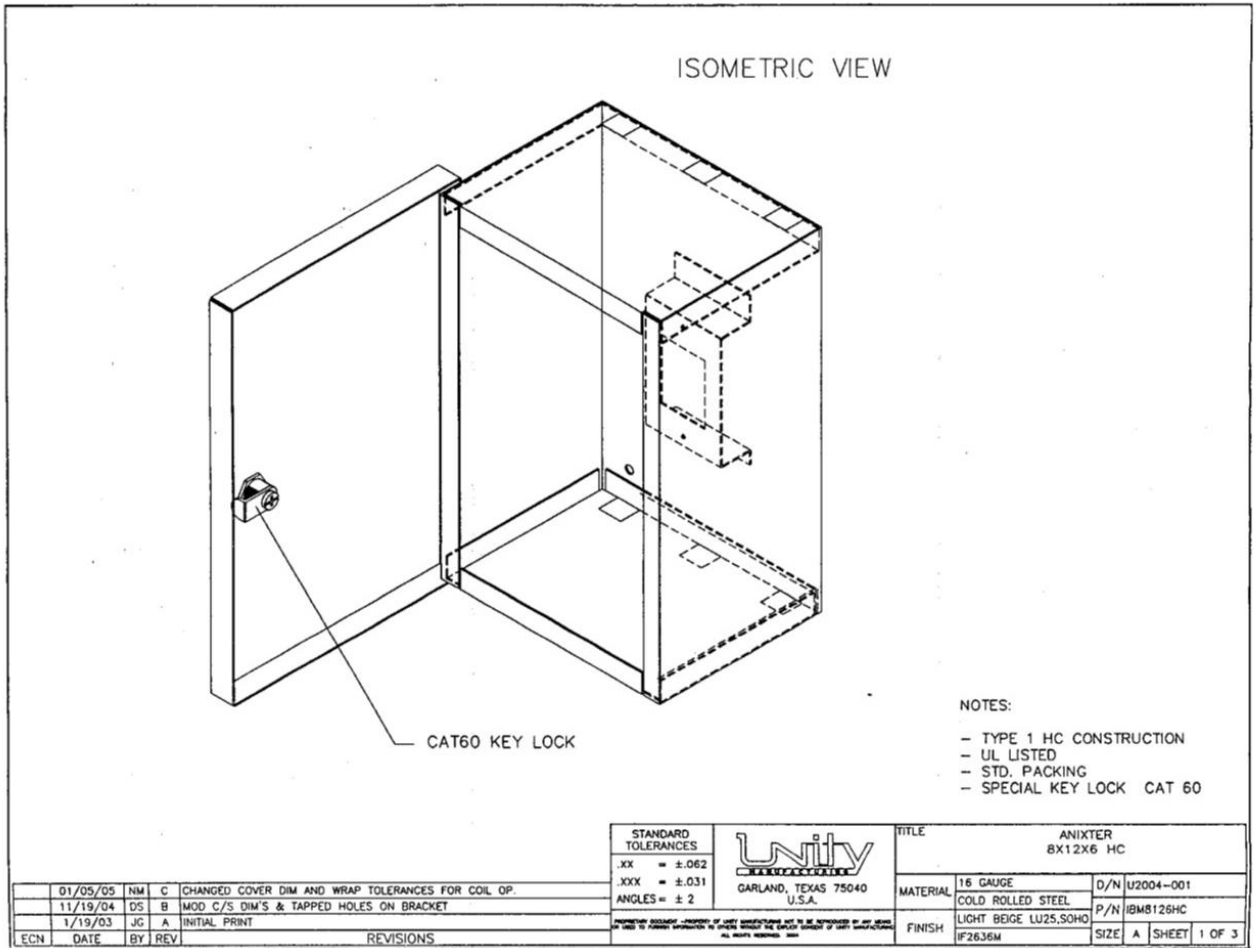

# Lockbox with Flange

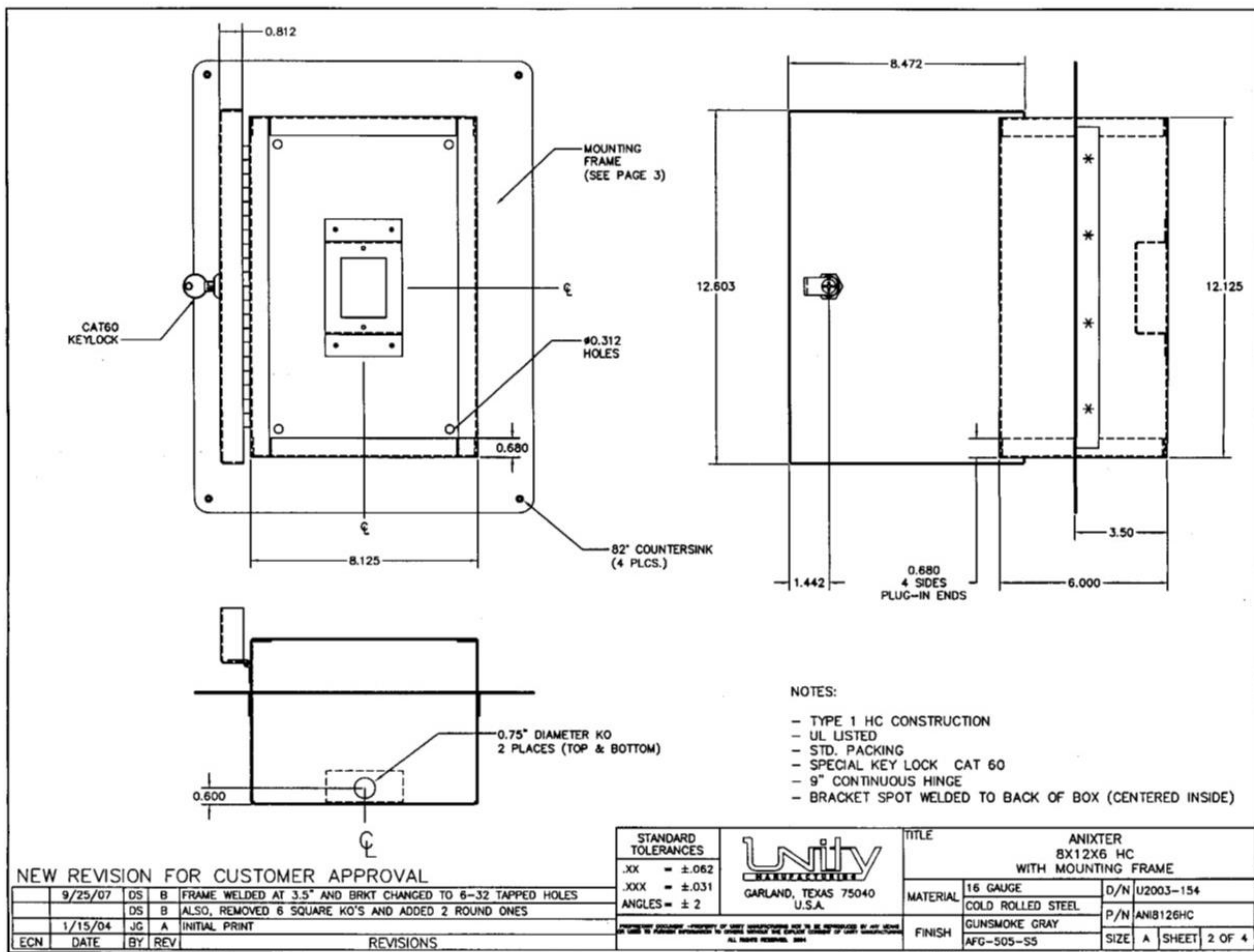

## Lockbox with Flange

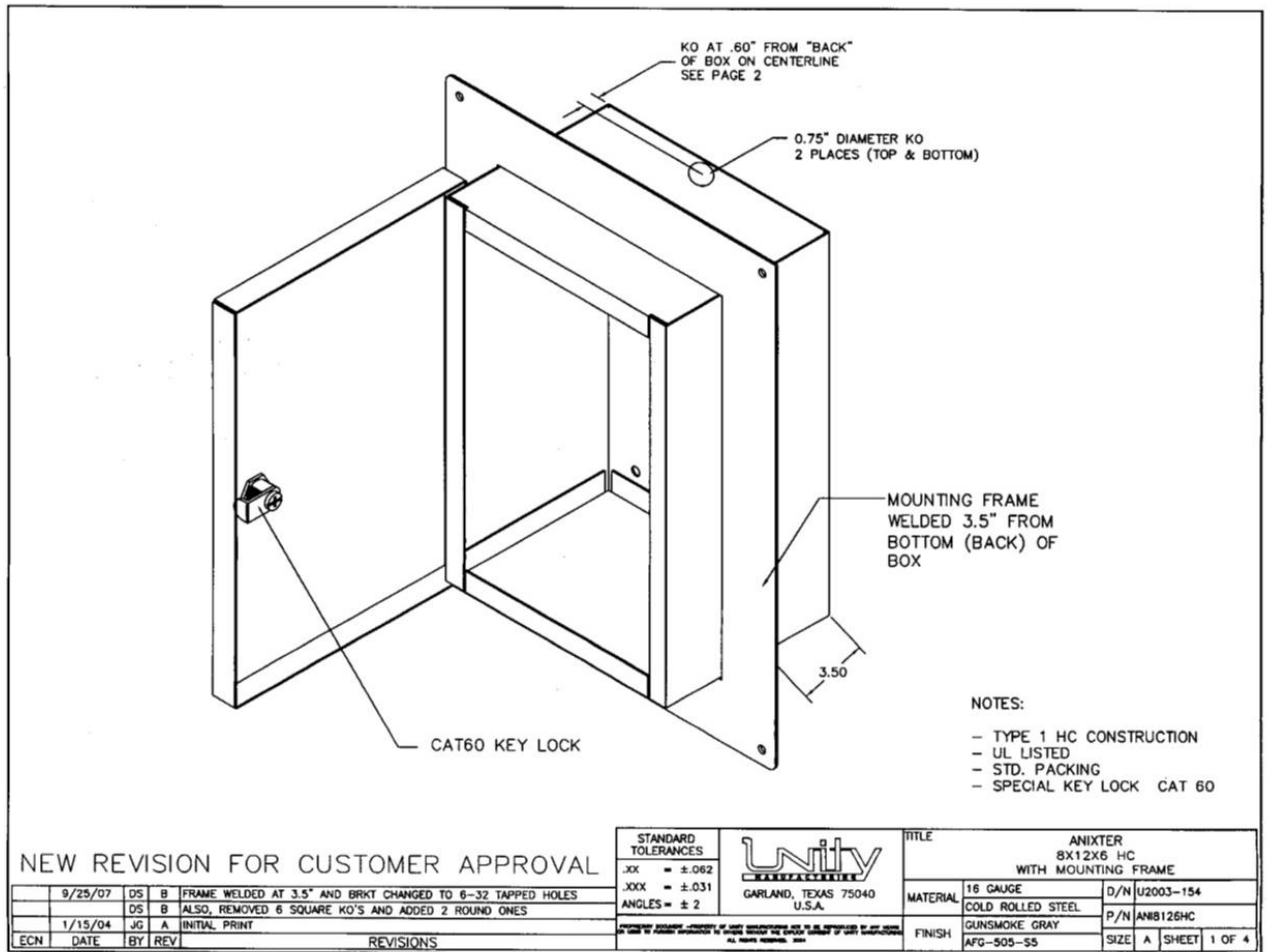

### Loud Bell

The loud bell must be industrial grade Wheelock TB-593 Tellbell Loud or industry equivalent. It is for use in noisy areas such as the auditorium, gymnasium, student cafeteria, kitchen and the boiler room. A loud bell is to be installed in the auditorium, gymnasium, student cafeteria, kitchen, and boiler room. The CAT 6 cable for this unit should be run to the nearest MDF/IDF and not tapped off of the phone. A loud bell may be required in other noisy areas. This will be determined by the OTS project manager working with the SCA and/or Contractor.

The loud bell is designed to provide a loud, attention-getting sound for use in noisy locations or for wide-area coverage. It includes an external volume control. All loud bells must be FCC registered for use with the public telephone network, PBX and key systems that use interrupted ring voltages from 55-130 VAC 20-3- Hz.

### Series TB - Telbells or Industry Equivalent

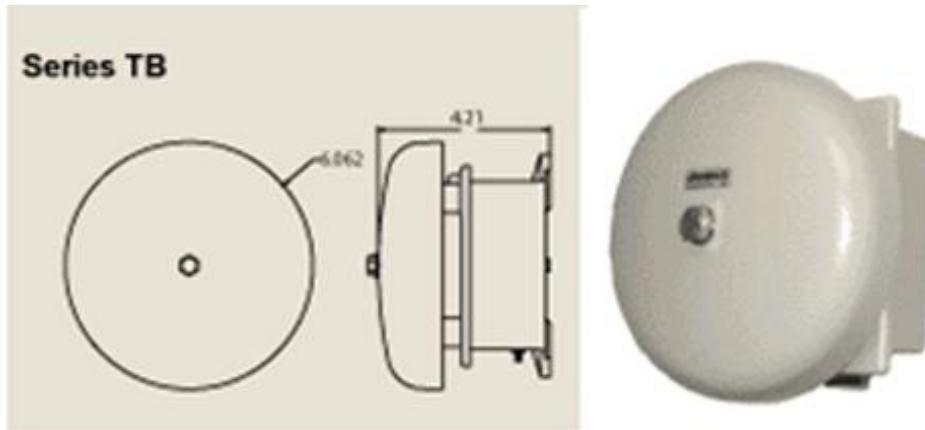

Available Features and options:

- Aluminum bell housing
- Shell Size: 6"
- Integral RFI suppression
- Screw terminal connections and RJ-11 plug
- Approvals Include: TB-593 is UL Listed
- Motor Driven
- Tamper resistant volume control
- Applications: Telephone Ringers
- Weatherproof backbox for indoor/outdoor
- Mounting included

		Order Code	Input Voltage	Input Current	dBA @10 ft.
<b>T591</b>	Gray	4102	38-60VDC	0.025	100
<b>T592</b>	Gray	4101	18-30 VAC/DC	0.025/0.030	100
<b>T593</b>	Gray	4103	55-130 V, 20-30 Hz	N/A	95

TB-593 or industry equivalent for phone systems with a programmed contact closure, DCI-24-24 power supply required.

### ***Cable Tags and Termination Labels***

Cables are to be tagged at both ends with an alpha and four-digit number beginning with (V or D) 001 and increasing in increments of 1. If the cable is designated for a voice station, the alpha will be a "V" and if designated for data, then the alpha should be a "D". This tag is applied at both the station and closet ends. It should be a sticky tag that is wrapped and secured to the cable behind both the jack faceplate and patch panel.

All cable and termination labels are unique identifiers, which should be permanent and comply with TIA/EIA-568-D labeling standards. At the closet end, the patch panel termination is labeled at the corresponding panel port with two points of information concerning the far end and each separated by a dash: 1) the room at the other end of the cable; and 2) the  *cable* number.

In addition, every patch panel within the building complex is to be identified with a unique 2-digit number permanently stamped, painted or labeled on the front middle top of each patch panel.

At the station side, the jack faceplate is labeled with two points of information pertinent to the cable far end and each separated by a dash: 1) the room number from the IDF or MDF; 2) the cable # on the jack faceplate (four digits). The cable numbers will be in sequence for each closet. For example, if there are 50 data cables coming from IDF 1, then the cable numbers will be D001 through D050. **Each closet would start over from D001.**

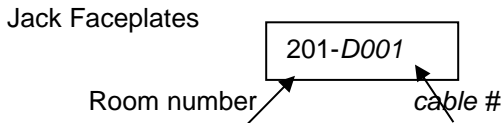
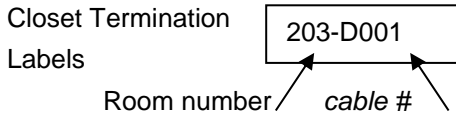

All cable and termination labels are unique identifiers, which should be permanent and comply with TIA/EIA-568-D labeling standards. At the closet end, the patch panel termination is labeled with two points of information concerning the far end and each separated by a dash: 1) the room at the other end of the cable; and 2) the cable number on the jack plate (*four digits*). The cable numbers will be in sequence for each closet. For example, if there are 50 voice cables coming from IDF 1, then the cable numbers will be V001 through V050. **Each closet would start over from V001.**

At the station side, the jack faceplate is labeled with two points of information pertinent to the cable far end and each separated by a dash: 1) the room number that the cable terminates from (IDF or MDF); and 2) the port number on the patch panel.

### Cable Labels

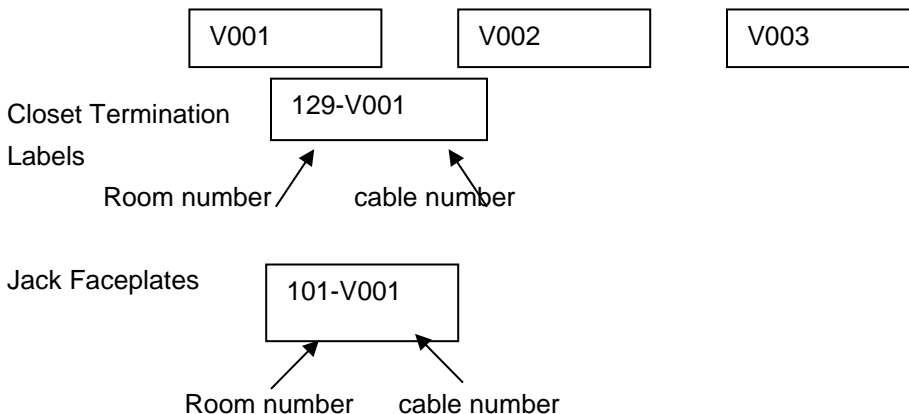

This method will allow the technician to easily identify both ends of the cable while keeping the label size small enough to fit over the patch panel ports.

### SCA Voice Rack

Voice equipment have their own racks. Terminate any associated voice cabling into the voice rack. The Voice racks will not have power strips. Electrical outlets for the Voice racks will be mounted on the ladder rack above their respective cabinets. In MDFs they require 3 feet of clearance all the way around. The IDF configuration of equipment in these racks is a 24-fiber interconnect panel terminating at the top of the voice rack riser termination, as shown in Figure D16 (specifications shown in Appendix D). The IDF voice

rack will contain 48 port patch panels and various configurations of voice switches. In the case of a large high school, the rack may also include voice server equipment. The number of patch panels and switches will vary by IDF, school, and scale in direct proportion to the number of devices that must be supported.

The specifications of these racks are shown here:

**Mighty Mo® 6 Cable Management Racks**

Racks are available in

6.5" channel depth, 7' high

45 rack units OR-MM6-706

Standard racks have a static load rating of 1500 lbs.

Description Part No.

OR-MM6-710



The cable management used in these racks are used to organize all cables connecting to the patch panels. Here is the specifications of the cable management:

**Mighty Mo® 6 Horizontal Cable Management Panels with Covers**

Description Part No.

1 RU: OR-MM6HMF1RU

2 RU: OR-MM6HMF2RU



Organizes patch cords vertically and horizontally on Mighty Mo 6 racks. Finger design encourages defined, traceable routing of individual patch cords.

## Appendix B – School Wireless

### MR56 Installation Guide

#### AP Mounting Bracket Description

##### MA-MNT-MR-14 (MR55/56)

The Meraki APs come with the mounting cradle and mounting hardware included. The mounting cradle has an integrated bubble level and a mounting template, and the accessory kit includes a security screw to secure the AP to the mounting bracket. The kit does not include masonry screws however but does include hollow wall anchors that can be used not only for sheetrock but in pre-drilled holes in brick or cinder block for example. The access points do have a Kensington lock hard point if they need to be cabled to a wall anchor.

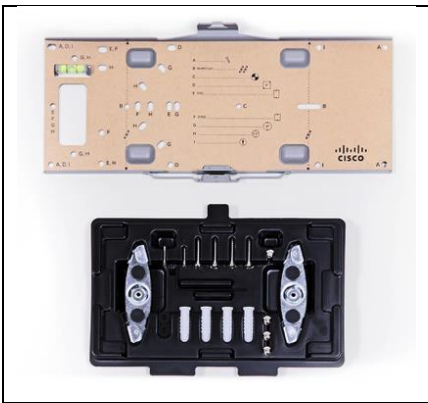

#### Product View and Physical Features

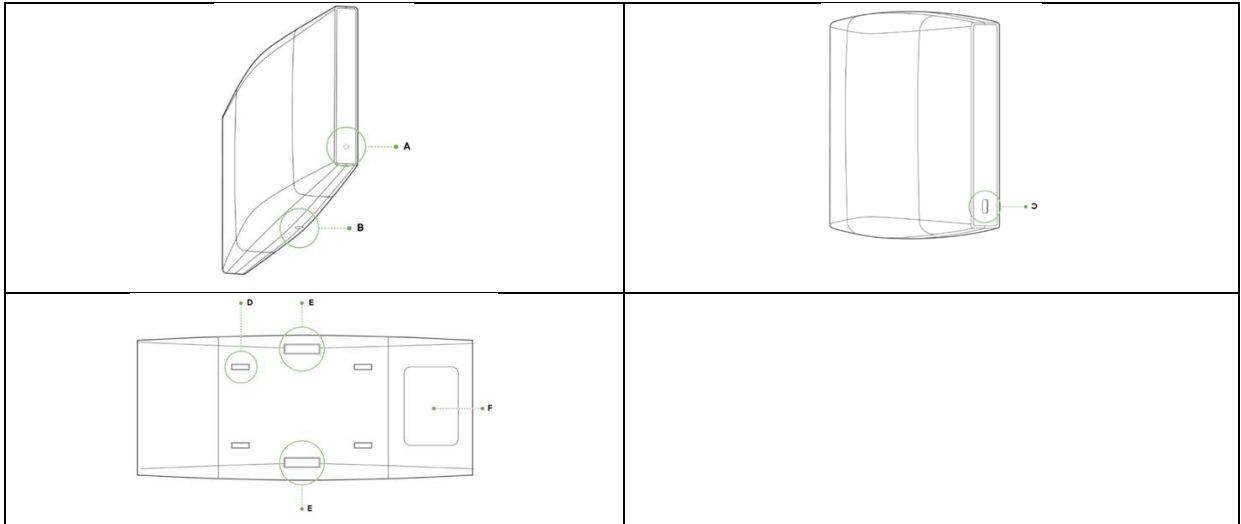

- A - LED indicator
- B - Security screw hole
- C - Kensington lock hard point
- D - Desk Mount feet
- E - Mount cradle attachment point F - Cable access bay

**The mount cradle has the following features:**

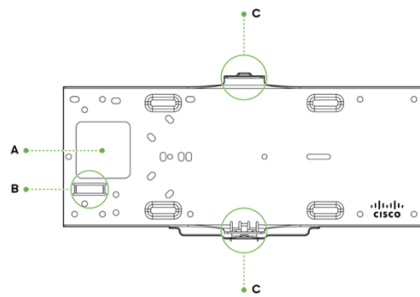

A - Cable access slot  
B - Level tool  
C - Mounting tab

## Security Features

The MR56 features multiple options for physically securing the access point after installation:

1. Security screw – The accessory kit includes screws that can be used to secure the access point to the mount cradle. Engaging the security screw prevents accidental dislodging and theft.
2. Kensington lock – The access point contains a hard point that allows it to be secured to any nearby permanent structure using a standard Kensington lock.

## Ethernet Ports

The MR56 features an Ethernet RJ45 port that accepts 802.3at power (labeled “Eth0, PoE”). This port should be used for uplink to your upstream network.

## Power Source Options

The MR56 access point can be powered using either the Meraki AC Adapter, PoE Injector (both sold separately), or a PoE switch.

## Factory Reset Button

If the button is pressed and held for at least five seconds and then released, the AP will reboot and be restored to its original factory settings by deleting all configuration information stored on the unit.

## LED Indicators and Run Dark Mode

Your access point is equipped with a multi-color LED light on the front of the unit to convey information about system functionality and performance:

- Orange - AP is booting (permanent Orange suggests hardware issue)
- Rainbow - AP is initializing/scanning
- Blinking Blue - AP is upgrading
- Green - AP in Gateway mode with no clients
- Blue - AP in Gateway mode with clients
- Blinking Orange - AP can't find uplink

**NOTE:** Blinking Green LED indicates that the device is in site survey mode. Please see the Conducting Site Surveys with MR Access Points for more details.

The MR56 access point may be operated in the “Run Dark” mode for additional security and to reduce the visibility of the access point. In this mode, the LED will not be illuminated. This mode may be enabled through the Meraki Dashboard.

## ***Installation Instructions***

### **Install the AP**

For most mounting scenarios, the access point mount cradle provides a quick, simple, and flexible means of mounting your device. The installation should be done in two steps. First, install the mount cradle to your selected location. Then, attach the AP to the mount cradle.

### **Attach the Mount Cradle**

The access point mount cradle can be used to install your access point in a wide range of scenarios: wall or solid ceiling, below a drop ceiling, on various electrical junction boxes.

The mount cradle contains a variety of hole patterns that are customized for each installation scenario. The mounting template (included in box with mount cradle) should be used to drill holes for wall mounts and also to identify the correct hole patterns in the mount cradle that should be used for each type of mount. The included mount cradle template shows the hole patterns that should be used for each type of mount.

### **Wall or Solid Ceiling Mount Using Mount Cradle**

Using included wall anchors and screws, attach the mount cradle to your mounting wall or ceiling. It is recommended that the AP be mounted to a wall or solid ceiling using the mount cradle for physical security reasons.

### **Drop Ceiling Mount using Mount Cradle**

To mount your AP on a drop ceiling T-rail, use the included drop ceiling mounting accessory kit. The accessory kit can be used to mount to most 9/16”, 15/16” or 1 1/2” T-rails. The kit contains:

1. Attach the T-rail clips to the T-rail by rotating them and snapping them into place as shown. The black foam pads should be compressed slightly after installation.

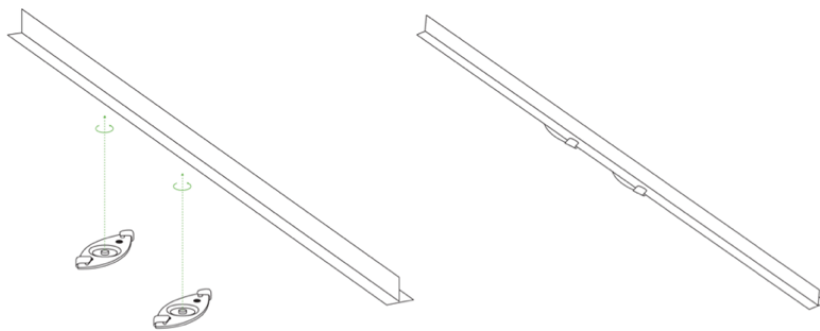

1. Using the dashed lines on the mount cradle template as a guide, set the proper spacing of the T-rail clips on the T-rail.
2. Tighten the set screws on the T-rail clips to secure the clips using a 5/64"(2 mm) hex key.

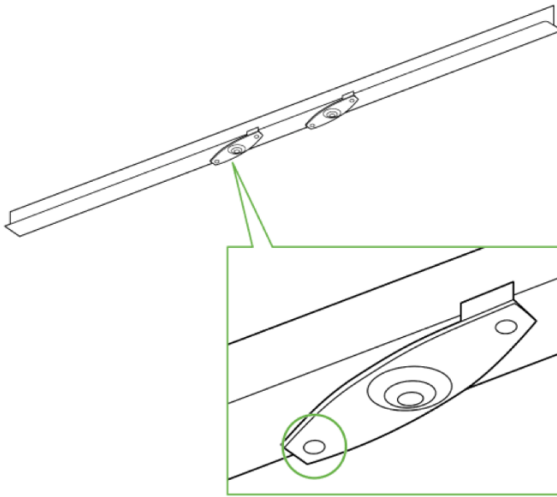

4. Attach the mount cradle to the T-rail clips using the mount cradle holes (marked with a "T").

Tip: Pre-assemble rubber spacers and screws to the mount cradle. The mount cradle can then be held with one hand while the other hand holds a screwdriver. If mounting your AP to a dropped ceiling, skip to the "Getting Power to the AP" section.

### **Electrical Junction Box Mount Using Mount Cradle**

The access point can be mounted to a 4" square cable junction box, a 3.5 or 4" round cable junction box, or various U.S. and European outlet boxes (mounting screws are not included).

Using appropriate mounting hardware for your specific type of junction box, attach the mount cradle to the junction box.

### **Getting Power to the AP**

If mounting to an electrical junction box, feed the Ethernet cable through the cable access hole in the mount cradle. If mounting to a wall or ceiling, the Ethernet cable will feed from behind the AP. The "Power Source Options" section of this document lists the different powering options and their unique characteristics.

## ***Mount the AP***

### **Attach the MR56 AP to the Mount Cradle**

(This section applies to wall and/or solid ceiling, drop ceiling, or electrical junction box mount where you have already installed the mount cradle.) The MR56 AP attaches to the mount cradle with two tabs on the cradle that insert into the MR56 AP and is secured to the cradle using one screw.

To attach the MR56 AP to the mount cradle properly, line up the top edge of the AP with the top tab of the mount cradle. Since the cradle is already mounted to the wall, guide the MR56 AP towards the top tab, and insert the top tab into the MR56 AP's slot.

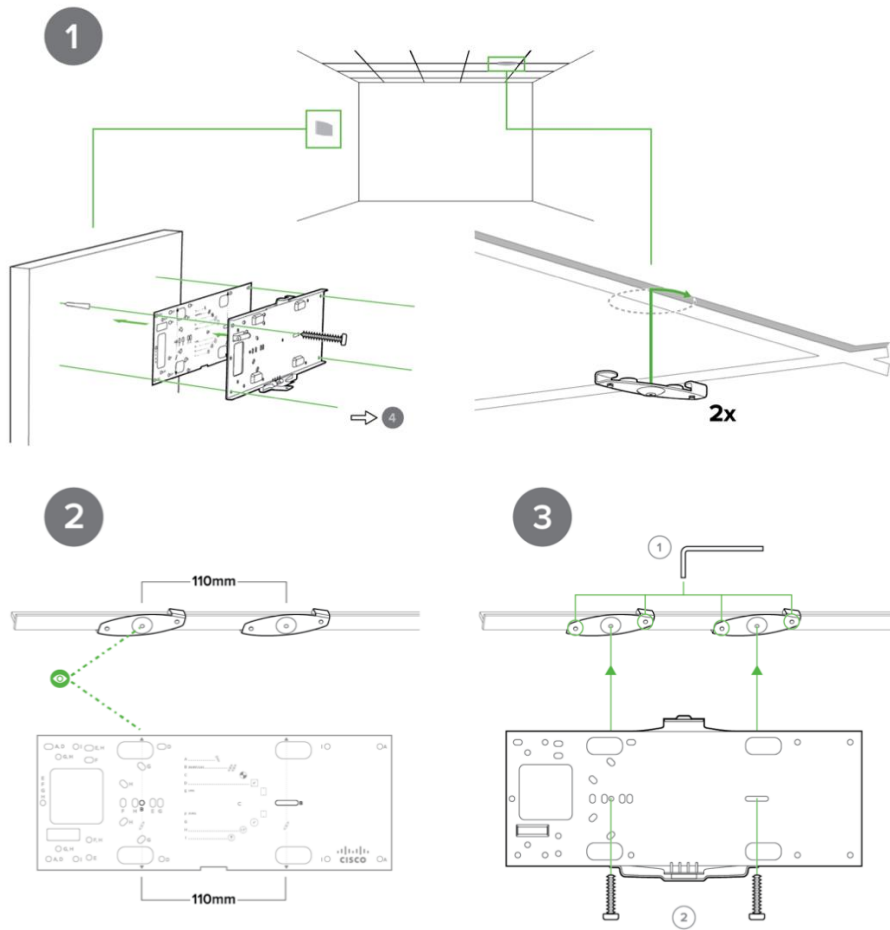

Then adjust the MR56 AP to guide the AP's bottom slot into the cradle's bottom tab until it clicks into place. Once in place, the MR56 AP should be secured to the cradle by using one of the included screws in the cradle's bottom tab.

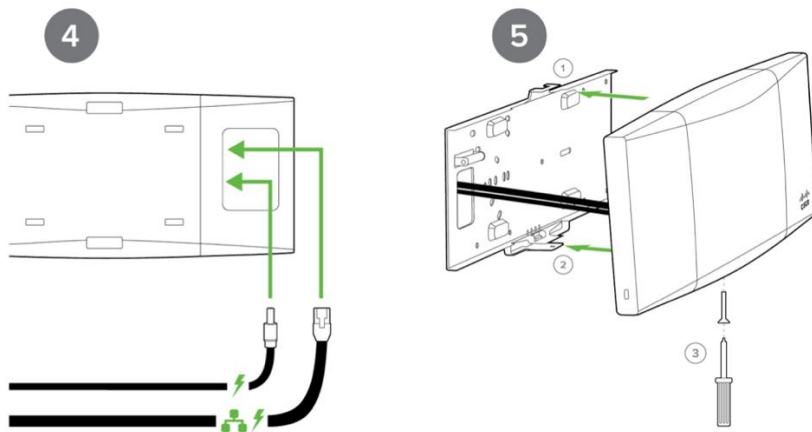

To release the AP from the mount cradle, first remove the security screw that secures the MR56 AP to the cradle's bottom tab. While holding the MR56 AP with one hand, press the cradle's bottom tab upwards, releasing the MR56 AP from the bottom of the cradle. Then remove the MR56 AP from the cradle's top tab.

## **Physical Security**

Depending on your mounting environment, you may want to secure the AP to its mount location. The access point can both be secured in several ways. If the AP has been installed using the mount cradle, it should be secured via security screw (Torx security screws are included) and/or Kensington lock. If the mount cradle was not used, the AP can still be secured using a Kensington lock.

### **Security Screw**



The accessory kit includes screws that can be used to secure the access point to the mount cradle. Engaging the security screw prevents accidental dislodging and theft.

### **Kensington Lock**

The access point contains a hard point that allows it to be secured to any nearby permanent structure using a standard Kensington lock. Attach a Kensington lock cable to the access point at the hard point on the side of the device. Attach the other end of the cable to a secure location, such as a pipe or building fixture.

## **MR46E with E6 Narrow Patch Antenna Installation Guide**

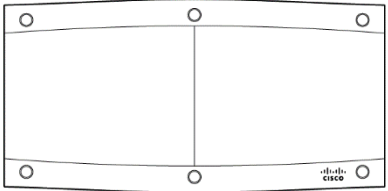
### **Product View and Physical Features**

<b>Meraki MR46E</b>	<b>MA-ANT-3-E6 Narrow Patch Antenna</b>
	

## Overview

The MR46E with E6 Wide Patch antenna is ideal for high ceiling (25+ ft) aesthetic consensus installations in high-density applications and where APs are covering high-density users in small zones. Some examples use cases are in large lecture halls/stadiums as well as event venue centers.

## MA-MNT-ANT-1 mounting arm

The MA-MNT-ANT-1 is a standard-length mounting arm designed for the MA-ANT-3-E\* and MA-ANT-3-F\* wide patch and narrow patch antennas.



Standard Length Adjustable Arm



78-101mm Hose Clamps



Mounting and Assembly Hardware

## Installation

### Step 1:

Fasten the MA-ANT-3E series antenna to the bracket using the 4x M6 bolts, 4x lock washer, and 4x flat washers provided.

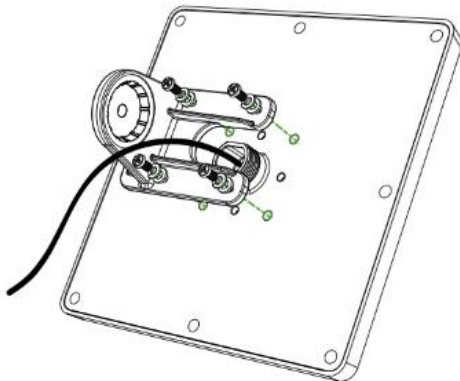

### Step 2A:

(Skip this step if using hose clamps)

Swivel arm out of the way to mount the arm to a wall using the provided screws and anchors.

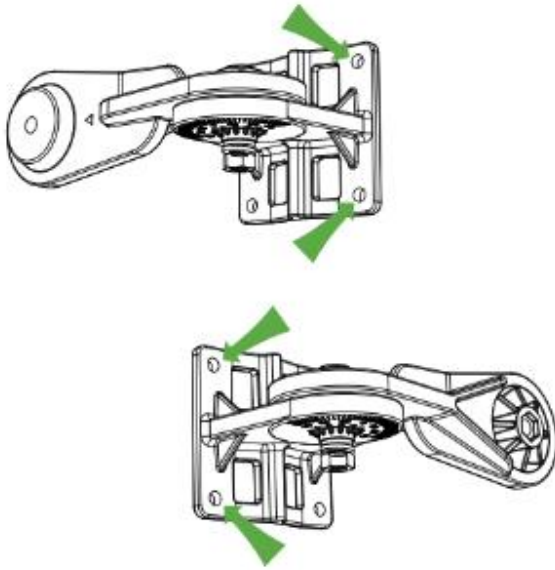

**Step 2B:**

(Skip this step if using screws & anchors)

Mount the arm to a 78-101mm diameter pole by feeding the adjustable hose clamps through the slots on the arm mount plate then tightening the hose clamp fasteners.

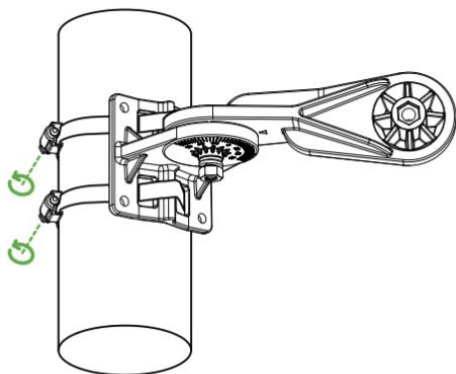

**Step 3:**

Adjust the arm to the desired direction and tighten the bolt fastening the arm and mount plate

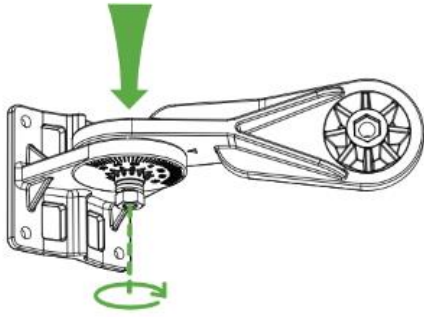

**Step 4:**

Assemble the bracket and antenna assembly to the arm using the bolt, lock, washer, flat washer, and nut provided.

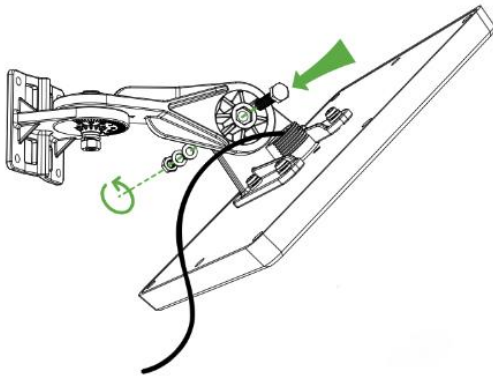

**Step 5:**

Connect each antenna cable to its corresponding connector type on the Meraki MR46E

## Appendix C – School IPDVS

---

### *Product Data Sheets*

#### Cisco Meraki MS390 Switch

##### Summary

Component Classification	Device Classification	Manufacturer	Model
Network Infrastructure	LAN Switch	Cisco	MS390-48UX2-HW

##### Power / Environmental Data

<b>Power Consumption</b>	
<b>Available PoE Power</b>	1100 Watts
<b>Power Connection</b>	Qty 1 - NEMA 5-15P
<b>Maximum Operating Temperature</b>	32° F to 104° F
<b>Size in RU</b>	1 RU

##### Device Identification

Visio Stencil Icon	Vendor Photo
	

#### Lenovo SR650 Server

##### Summary

Component Classification	Device Classification	Manufacturer	Model
Network Infrastructure	Server	LENOVO	SR650

Power / Environmental Data

<b>Power Consumption</b>	750 Watts/Unit Power Supply
<b>Power Connection</b>	Qty 2 - NEMA 5-15P
<b>HVAC / BTU Output</b>	3550 BTU/hr.
<b>Maximum Operating Temperature</b>	104° F
<b>Size in RU</b>	2U

Device Identification

Visio Stencil Icon	Vendor Photo
	

**Belkin Rack Console**

Summary

Component Classification	Device Classification	Manufacturer	Model
RACK CONSOLE	Belkin 19-inch Widescreen Rack Console	Belkin	OmniView Pro 3

Power / Environmental Data

<b>Power Consumption</b>	Belkin PRO3 KVM cables are required to connect your servers and computers. To find the right cables for your model: USB cable MFR #F1D9401-06
<b>Power Connection</b>	Auto-Switching 100 to 240VAC, 50 to 60Hz, 48 Watt
<b>Maximum Operating Temperature</b>	32° to 104°F(0° to 40°C)
<b>Size in RU</b>	1 RU

Device Identification

Visio Stencil Icon	Vendor Photo
No Visio Icon Available	

**Server Cabinet**

Summary

Component Classification	Device Classification	Manufacturer	Model
Physical Infrastructure	Custom Cabinet	APC	AR3150

Power / Environmental Data

<b>Power Consumption</b>	N/A
<b>Power Connection</b>	N/A
<b>HVAC / BTU Output</b>	N/A
<b>Maximum Operating Temperature</b>	N/A
<b>Size in RU</b>	42U Cabinet

Device Identification

Visio Stencil Icon	Vendor Photo
--------------------	--------------



**IDF Wall Mount Cabinet – 12RU Cabinet Option-A**

Summary



Component Classification	Device Classification	Manufacturer	Model
Physical Infrastructure	Custom Cabinet	Middle Atlantic	CWR-12-32PD (Cabinet) CWR-FKIT (Fan Kit) CWR-RR12 (Rear Rail Kit) Front Rail Kit included w/ cabinet

Power / Environmental Data

<b>Power Consumption</b>	N/A
<b>Power Connection</b>	N/A
<b>HVAC / BTU Output</b>	N/A
<b>Maximum Operating Temperature</b>	N/A

<b>Size in RU</b>	12U Cabinet
-------------------	-------------

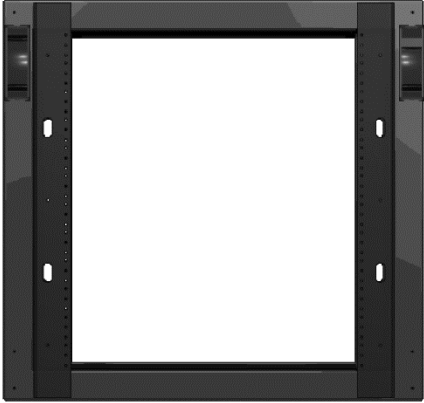
Device Identification

<b>Visio Stencil Icon</b>	<b>Vendor Photo</b>
	

**Lobby Viewing Console – Standard Console**

Summary

<b>Component Classification</b>	<b>Device Classification</b>	<b>Manufacturer</b>	<b>Model</b>
Viewing Station Furniture	Workstation Cabinet	eSystems	See below



Device Identification

MODEL#	WIDT H	DEPT H	DESCRIPTION
90338-SCA-48-S-7583M- H305-GR10	48	30	STRAIGHT MVS DESK WITH TWO DRAWER AND CPU COMPARTMENT

90338-SCA-48-W-7583M-H305-GR10	48	30	STRAIGHT MVS DESK ON COSTER WHEELS WITH TWO DRAWER AND CPU COMPARTMENT
90338-SCA-60-S-7583M-H305-GR10	60	30	STRAIGHT MVS DESK WITH THREE DRAWER AND CPU COMPARTMENT
90338-SCA-72-S-7583M-H305-GR10	72	30	STRAIGHT MVS DESK WITH FOUR DRAWER AND CPU COMPARTMENT
90339-SCA-48L-S-7583M-H305-GR10	48	24	LEFT ANGLED(FROM BEHIND THE DESK) MVS DESK WITH ONE DRAWER AND CPU COMPARTMENT
90339-SCA-48R-S-7583M-H305-GR10	48	24	RIGHT ANGLED(FROM BEHIND THE DESK) MVS DESK WITH ONE DRAWER AND CPU COMPARTMENT
90339-SCA-48L-W-7583M-H305-GR10	48	24	LEFT ANGLED(FROM BEHIND THE DESK) MVS DESK ON COSTER WHEELS WITH ONE DRAWER AND CPU COMPARTMENT
90339-SCA-48R-W-7583M-H305-GR10	48	24	RIGHT ANGLED(FROM BEHIND THE DESK) MVS DESK ON COSTER WHEELS WITH ONE DRAWER AND CPU COMPARTMENT
90490-SCA-72.72-L-7583M-H305-GR10	72	72	LEFT HAND (FROM BEHIND THE DESK)"L" SHAPED SECURITY MVS DESK WITH BOX/BOX/FILE DRAWER AND CPU COMPARTMENT
90490-SCA-72.72-R-7583M-H305-GR10	72	72	RIGHT HAND (FROM BEHIND THE DESK)"L" SHAPED SECURITY MVS DESK WITH BOX/BOX/FILE DRAWER AND CPU COMPARTMENT
90673-SCA-72.60-L-7583M-H305-GR10	72	60	LEFT HAND (FROM BEHIND THE DESK) ANGLED SECURITY MVS DESK WITH BOX/BOX/FILE DRAWER AND CPU COMPARTMENT
90673-SCA-72.60-R-7583M-H305-GR10	72	60	RIGHT HAND (FROM BEHIND THE DESK) ANGLED SECURITY MVS DESK WITH BOX/BOX/FILE DRAWER AND CPU COMPARTMENT

**Note:**

Custom millwork consoles may be used, if the designer follows the guidelines outlined in Specification 16783 Section 2.06 *Console for Viewing Station*.

When deciding on the size and location of furniture, keep egress in mind; fixed equipment or equipment that is difficult to move. Please check with the custodial staff to ensure compliance with building codes.

## Lobby Viewing Console Alternative – Rolling Cart

### Summary

Component Classification	Device Classification	Manufacturer	Model
Viewing Station Furniture	Computer Rolling Cart	Datamation Systems, Inc.	DS-3518-GMQ-T-2M-MK

### Device Identification

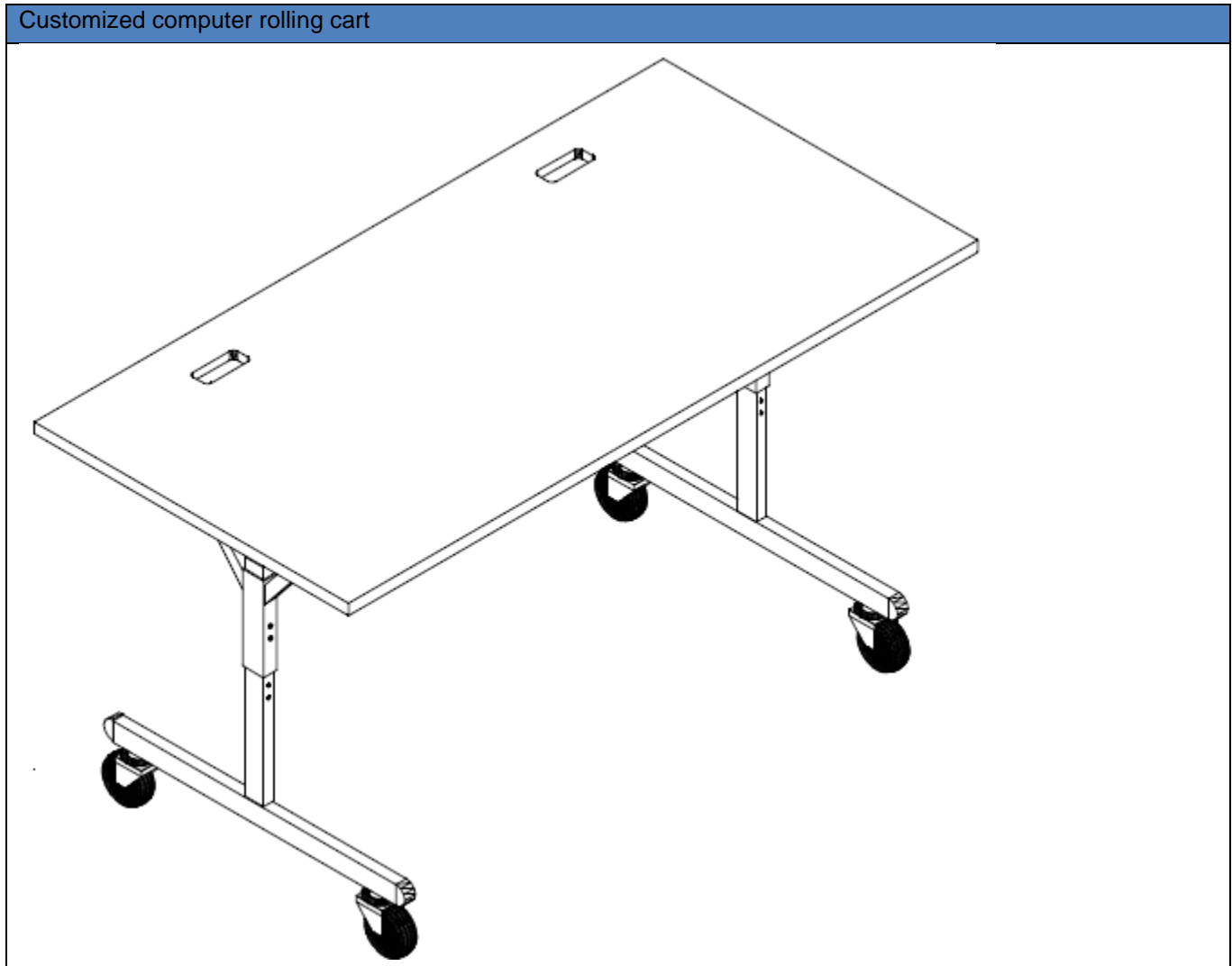

## Uninterruptible Power Supply (UPS)

### Summary

Component Classification	Device Classification	Manufacturer	Model
IPDVS Infrastructure	UPS	APC	SMX3KR2UNCX145

### Power / Environmental Data

<b>Power Consumption</b>	2850 Watts Max
<b>Power Connection</b>	Qty 1. – 120V NEMA L5-30P / 10FT Cord
<b>HVAC / BTU Output</b>	300 BTU/hr.
<b>Maximum Operating Temperature</b>	104°F
<b>Size in RU</b>	2U

### Device Identification

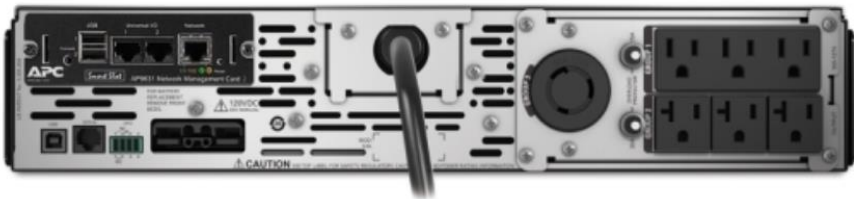
Visio Stencil Icon	Vendor Photo
No Visio Icon Available	

## AXIS T8125 HIGH PoE+ 60 WATT MIDSPAN 1-PORT (POWER INJECTOR)

### Summary

Component Classification	Device Classification	Manufacturer	Model
IPDVS Infrastructure	Power over Ethernet	Axis	T8154 (5901-004)

### Power / Environmental Data

<b>Power Consumption</b>	60W
<b>Nominal Output Voltage</b>	55 V DC
<b>Power Connection</b>	

<b>HVAC / BTU Output</b>	N/A
<b>Maximum Operating Temperature</b>	-40°C to 50°C for 60 Watts (-40°F to 131°F)
<b>Size in RU</b>	N/A

#### Interface

<b>Input (DATA IN): Ethernet 10/100/1000Base-T</b>	RJ45 female socket, SFP port media converter
<b>Output (DATA PWR OUT): Ethernet 10/100/1000Base-T, plus 55 V DC</b>	RJ45 female socket, with DC voltage on wire pairs 1-2 & 3-6, 4-5 & 7-8.
<b>Power Cable (LINE AC)</b>	Pre-installed 3m power cable

#### Device Identification

Visio Stencil Icon	Vendor Photo
	

<https://classic.www.axis.com/en-us/products/axis-t8154-60-w-sfp-midspan/>

### FIXED POSITION – INDOOR/OUTDOOR VANDAL RESISTANT CAMERA

#### Summary

Component Classification	Device Classification	Manufacturer	Model
IPDVS Infrastructure	Camera	Axis	P3375-LVE (01063-001)

#### Power / Environmental Data

<b>Power Consumption</b>	12.1W
<b>Power Connection</b>	Power over Ethernet IEEE 802.3af Class 3
<b>HVAC / BTU Output</b>	N/A
<b>Maximum Operating Temperature</b>	- 40 to 55 °C (-40 to 131 °F), humidity 10 - 100% RH (condensing)
<b>Size in RU</b>	N/A
<b>Lens</b>	Varifocal, 3–10 mm, F1.4, Horizontal field of view: 90°–34°, Vertical field of view: 50°–20°

Device Identification

Visio Stencil Icon	Vendor Photo	
		

**M3057-PLVE MK II – 6 MP - 180°/360° Indoor/Outdoor**



Summary

Component Classification	Device Classification	Manufacturer	Model
IPDVS Infrastructure	Camera	Axis	M3057-PLVE MK II (02109-001)

Power / Environmental Data

<b>Power Consumption</b>	Typical 8.0 W, max 11.9 W
<b>Power Connection</b>	Power over Ethernet (PoE) IEEE 802.3af/802.3at Type 1 Class 3
<b>HVAC / BTU Output</b>	N/A
<b>Maximum Operating Temperature</b>	- 40 to 50 °C (-40 to 122 °F), humidity 10 - 100% RH (condensing)
<b>Size in RU</b>	N/A
<b>Lens</b>	1.56 mm, F2.0 Horizontal field of view: 183° Vertical field of view: 183° Fixed iris, fixed focus

Device Identification

Visio Stencil Icon	Vendor Photo	
		

**AXIS P3719-PLE – 4 Way 16MP – indoor/outdoor**

Summary

Component Classification	Device Classification	Manufacturer	Model
IPDVS Infrastructure	Camera	Axis	P3719-PLE (01500-001)

Power / Environmental Data

<b>Power Consumption</b>	Typical 16.3, max 25.5 W
<b>Power Connection</b>	Power over Ethernet (PoE) IEEE 802.3at Type 1 Class 3
<b>HVAC / BTU Output</b>	N/A
<b>Maximum Operating Temperature</b>	- 40 to 50 °C (-40 to 122 °F), humidity 10 - 100% RH (condensing)
<b>Size in RU</b>	N/A
<b>Lens</b>	Varifocal 3-6 mm, F1.8 – 2.6 4 x 1440p

Device Identification

Visio Stencil Icon	Vendor Photo	
		



**AXIS P9106-V White – 3MP – Indoor corner camera**

Summary

Component Classification	Device Classification	Manufacturer	Model
IPDVS Infrastructure	Camera	Axis	P9106-V (01620-001)

Power / Environmental Data

<b>Power Consumption</b>	Typical 2.8, max 3.2 W
<b>Power Connection</b>	Power over Ethernet (PoE) IEEE 802.3af/at Type 1 Class 1
<b>HVAC / BTU Output</b>	N/A
<b>Maximum Operating Temperature</b>	- 40 to 50 °C (-40 to 122 °F), humidity 10 - 100% RH (condensing)
<b>Size in RU</b>	N/A
<b>Lens</b>	Varifocal 1.8 mm, F2.4, Horizontal field of view: 130° Vertical field of view: 95°

Device Identification

Visio Stencil Icon	Vendor Photo	
		

## AXIS P5655-E – Indoor Small Form Factor PTZ



### Summary

Component Classification	Device Classification	Manufacturer	Model
IPDVS Infrastructure	Camera	Axis	P5655-E (01682-004)

### Power / Environmental Data

<b>Power Consumption</b>	TYPICAL 10.5 W, MAX19 W
<b>Power Connection</b>	High Power over Ethernet (High PoE) IEEE 802.3at
<b>HVAC / BTU Output</b>	N/A
<b>Maximum Operating Temperature</b>	-50 °C to 50 °C (-58 °F to 122 °F) Arctic Temperature Control enables camera start-up at temperatures as low as -40 °C (-40 °F) Humidity 10–100% RH (non-condensing)
<b>Size in RU</b>	N/A
<b>Lens</b>	

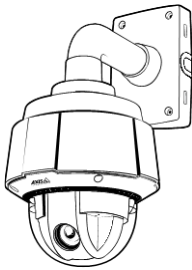
### Device Identification

Visio Stencil Icon	Vendor Photo
	

## PTZ CAMERA – OUTDOOR



### Summary

Component Classification	Device Classification	Manufacturer	Model
IPDVS Infrastructure	Camera	Axis	Q6075-E (01752-004)

### Power / Environmental Data

<b>Power Consumption</b>	60 W : typical 14 W, max 51 W
<b>Power Connection</b>	High Power over Ethernet (High PoE) IEEE 802.3at
<b>HVAC / BTU Output</b>	N/A
<b>Maximum Operating Temperature</b>	-50 °C to 50 °C (-58 °F to 122 °F) Arctic Temperature Control enables camera start-up at temperatures as low as -40 °C (-40 °F) Humidity 10–100% RH (non-condensing)
<b>Size in RU</b>	N/A
<b>Lens</b>	

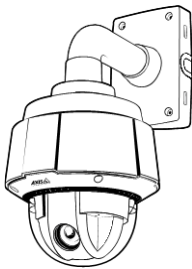
### Device Identification

Visio Stencil Icon	Vendor Photo
	

## PTZ CAMERA PARAPET MOUNTS



### Summary

Component Classification	Device Classification	Manufacturer	Model
IPDVS Infrastructure	Bracket	Multiple	Multiple

### Power / Environmental Data

Power Consumption	N/A
Power Connection	N/A
HVAC / BTU Output	N/A
Maximum Operating Temperature	N/A
Size in RU	N/A

### Device Identification

Device Photo	Device Photo	Device Photo
		
<b>VideoAlarm</b> <b>PRM30G</b> <b>23.3" Horizontal Span</b>	<b>VideoAlarm</b> <b>PRM50G</b> <b>38.3" Horizontal Span</b>	<b>VideoAlarm</b> <b>VG4-A-9230</b> <b>40.2" Horizontal Span</b>

#### Note:

Regardless of which parapet mount is used, the installer must ensure the entire camera dome, not just the lens, extends fully beyond the outer edge of the building's parapet.

## CAMERA BRACKETS AND MOUNTS (AXIS ONLY)



### Summary

Component Classification	Device Classification	Manufacturer	Model
IPDVS Infrastructure	Bracket	AXIS	See below

### Power / Environmental Data

Power Consumption	N/A
Power Connection	N/A
HVAC / BTU Output	N/A
Maximum Operating Temperature	N/A
Size in RU	N/A

### Device Identification

	
AXIS T91D61 Wall Mount 1.5" NPS (5504-821)	AXIS T91A64 Corner Bracket / 5017-641

## EXTERIOR CAMERA INTERFACE ENCLOSURE – GENERAL

### Summary



Component Classification	Device Classification	Manufacturer	Model
IPDVS Infrastructure	Cabling Enclosure	Eaton	Type C & LB

### Power / Environmental Data

Power Consumption	N/A
Power Connection	N/A
HVAC / BTU Output	N/A

<b>Maximum Operating Temperature</b>	N/A
<b>Size in RU</b>	N/A

Device Identification

<b>Visio Stencil Icon</b>	<b>Vendor Photo</b>
No Visio Icon Available	
	Eaton type C & LB Conduit (Condulet outlet Bodies)
	
	Steel face plate with Integral Gasket

**EXTERIOR CAMERA INTERFACE ENCLOSURE - WALL MOUNT CAMERA**

Summary

<b>Component Classification</b>	<b>Device Classification</b>	<b>Manufacturer</b>	<b>Model</b>
IPDVS Infrastructure	Cabling Enclosure	acceltex	ATS-1084P-S-L-CG-BBP-CUST1

Power / Environmental Data

<b>Power Consumption</b>	N/A
<b>Power Connection</b>	N/A
<b>HVAC / BTU Output</b>	N/A
<b>Maximum Operating Temperature</b>	N/A
<b>Size in RU</b>	N/A

Device Identification

<b>Vendor Photo</b>
---------------------



NYDOE 10x8x4 Polycarbonate  
Enclosure with Solid Door, Latch  
Lock and Cord Grip (Outdoor  
Analog use only) ask vendor for  
installation instructions  
ATS-1084P-S-L-CG-BBP-CUST1

## ***Comprehensive Technical Support***

### **IPDVS SUPPORT**

The NYCDOE DIIT offers comprehensive technical support for the IPDVS system. Schools should call the DIIT help desk “Live Support” at 718-935-5100 to request assistance with the IPDVS systems including the software and user accounts. Schools should call the help desk to report any camera outages or other problems with IPDVS system performance. Schools that have PTZ cameras may also call the help desk for assistance in configuring home positions, preset views, and automated tours. Schools may also contact the help desk to revise/correct the names of cameras listed in the software. When calling the helpdesk, users must reference “**IPDVS**” to ensure proper routing of the call. Please be sure to record the ticket number(s) for future reference.

DIIT also offers support online using the “Service Desk Online”:

<https://servicecenter.nycenet.edu/selfsupport/login.asp>

The goal of the support model is to ensure that problems are accurately logged, tracked, and directed to the appropriate resources for prompt resolution. The support team is capable of resolving many common problems remotely by communicating with system components over the wide-area network.

### **USER ACCOUNTS**

DIIT will create and communicate unique IPDVS login credentials to all IPDVS users. School principals should periodically review the list of authorized IPDVS users for their site and submit updates due to staff turnover.

## **RETENTION OF VIDEO EVIDENCE**

Archived video is stored locally on the server at each school with a retention target of 60 days. The actual storage duration depends on the storage capacity of the server at that site. Because each server has a finite storage capacity, the oldest video is constantly being overwritten by the newest even if the older video has been bookmarked.

As soon as it is determined that a particular video segment is needed, a video evidence export request form should be submitted using the Online Occurrence Reporting System (OORS). The support team will respond by sending an email notification indicating the status of the export. If successful, an email will be sent confirming the request was processed and communicating the UPS tracking number of the CD OR DVD package. If an export problem is encountered, the support team will respond with further details of the issue.

If a school needs to retain a permanent copy of the video segment that does not pertain to an occurrence reported in OORS, they may complete a request form in MS Word format. If a school requires a blank copy of the MS Word request document, they may obtain it by emailing the IPDVS help desk at [VIDEOEXPORT@schools.nyc.gov](mailto:VIDEOEXPORT@schools.nyc.gov)

## **TRAINING**

The DIIT comprehensive support program offers refresher training sessions conducted on a quarterly basis at their MetroTech offices in Brooklyn. To reserve a seat, please send a request by email to [IPDVSTraining@schools.nyc.gov](mailto:IPDVSTraining@schools.nyc.gov)

DIIT has created a Quick Reference Guide explaining how to use the IPDVS application for live viewing and playback of recorded archives. To request a copy of the Quick Reference Guide please send a request by email to [IPDVSTraining@schools.nyc.gov](mailto:IPDVSTraining@schools.nyc.gov)

## **PRECAUTIONS**

In accordance with our goal of keeping all these systems running smoothly, the importance of schools keeping their telecommunication closets secure and tidy should be emphasized. These rooms contain expensive and sensitive equipment including video surveillance servers and encoders. The importance of locking electrical panels and circuit breakers should also be emphasized. Following these precautions will reduce service disruptions and make it easier for IPDVS technicians to access the telecommunications racks and cabinets.

## Appendix D – School Networking

### Network Design Diagrams

#### WAN Network Architecture Diagrams

These figures give an overview of the overarching WAN network architecture at the NYCDOE and the corresponding Internet traffic flow. The Classroom Connect network provides EVPL connections between School sites and the fiber network. Almost all sites now connect via EVPL. All new sites receive EVPL, if possible. Depending on the size of the school, EVPL connections can range from 300 to 500 Mbps CIR.

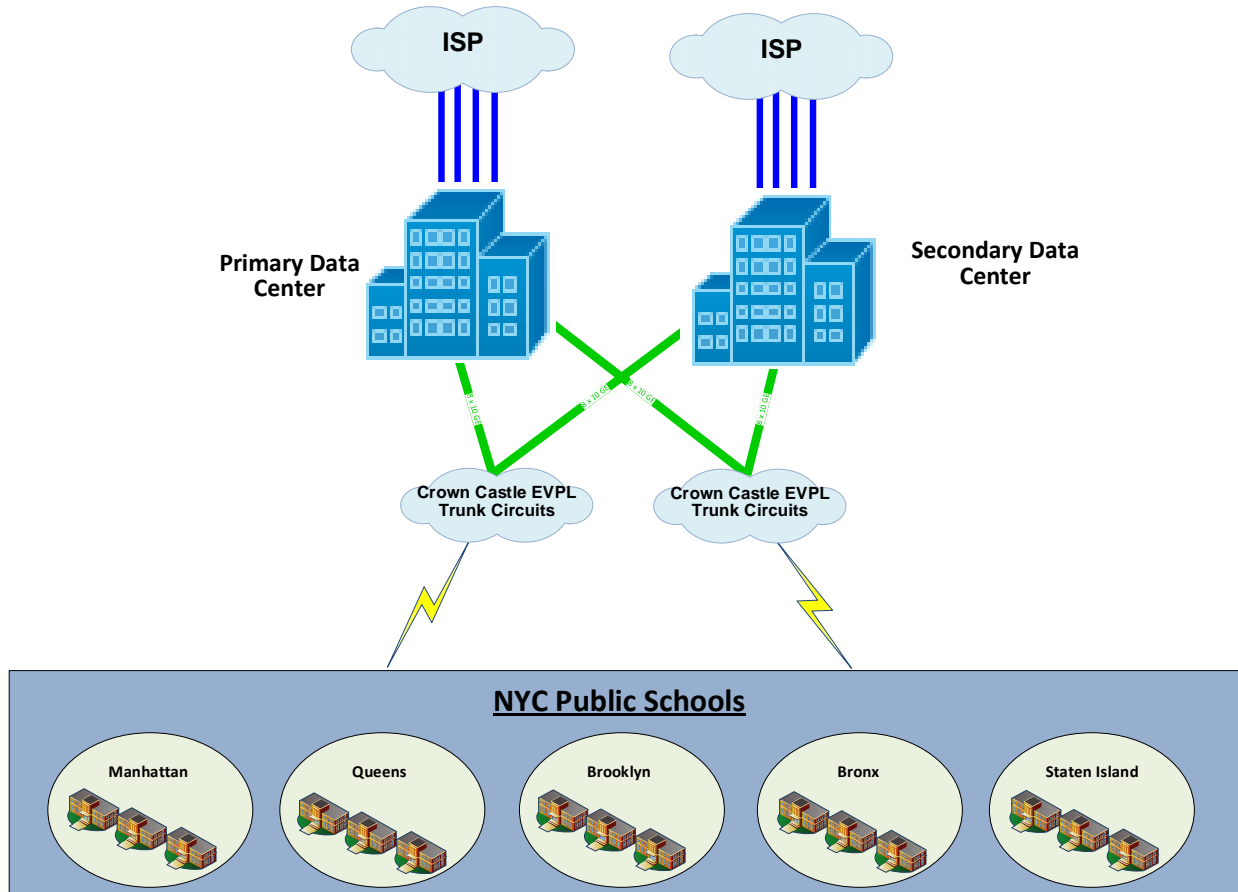

Figure D1: High Level Network Diagram

## IP Address Assignments

### Typical IP Address Assignment for Medium, and Large School Sites

Each Medium, and Large School site will be assigned two blocks of 4000 addresses and one 1000 address block which will be used to allocate sub-networks for each local area network (LAN). The following Figures and Tables provide IP address allocation details.

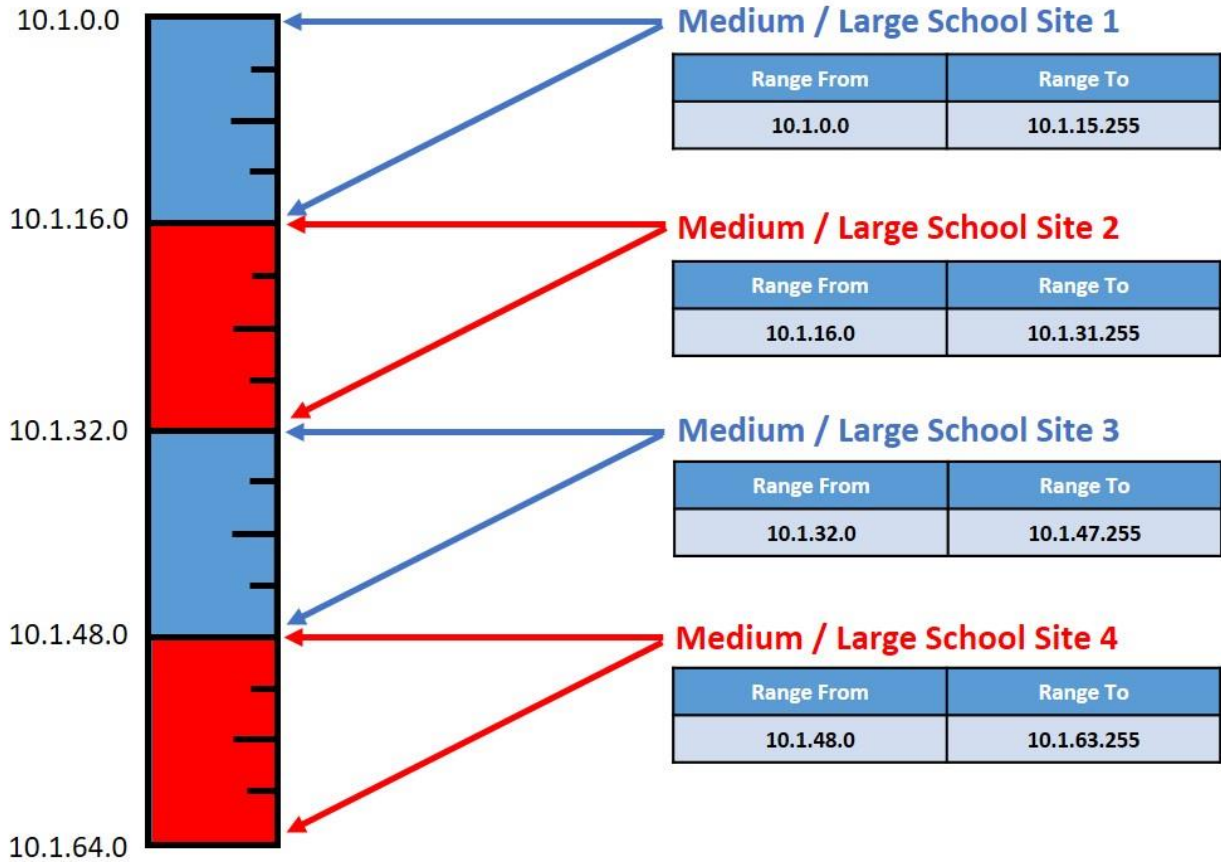

Figure D2 – Medium/Large School Address Scope – First 4000 -address block

**Table D1: Medium / Large School VLAN IPs**

VLAN	Function	Subnet	Available Addresses	Description
N/A	Layer 3 link to WAN	(octet1).(octet2).(octet3+10).0 /30	2	Point-to-point link to edge
N/A	Terminal Server to Router	N/A		C1100
1	Management VLAN	(octet1).(octet2).(octet3+8).0 /23	510 (static .1 - .100)	Meraki Devices management traffic
2	Admin Users	(octet1).(octet2).(octet3+12).0 /23	510 (static .1 - .40)	All admin traffic
211	User Access (Standard)	(octet1).(octet2).(octet3).0 /20	4094 (static .1 - .100)	All user traffic
211	User Access (extended scope)	(octet1).(octet2).(octet3).0 /19	8190 (static .1 - .100)	All user traffic at very large schools (100.64.0.0/10)
260	Guest	192.168.64.0 /19	8190 (static .1 - .100)	Same scope for all sites (local DHCP)
411	IoT	(octet1).(octet2).(octet3).0 /22	1022 (static 1 <sup>st</sup> half)	IoT with internet access
412	IoT Secure	(octet1).(octet2).(octet3+4).0 /22	1022 (static 1 <sup>st</sup> half)	IoT without internet access
501	Voice / Collaboration	Specific for each site	as needed	Per-site scope
N/A	R1 Lo10 / Router ID	(octet1).(octet2).(octet3+15).129 /32	1	Router ID
N/A	X1 Lo10	(octet1).(octet2).(octet3+15).131 /32	1	X1 Loopback

**Note:**

**VLAN 211 uses a completely different scope.**

**Table D2: Small School VLAN IPs**

VLAN	Function	Subnet	Usable Address Range
1	Infrastructure Management	10.X.Y.0 /28	10.X.Y.1 - 10.X.Y.14
100	Wireless Management	10.X.Y.16 /28	10.X.Y.17 - 10.X.Y+1.30
10	Wired Instructional Users	10.X.Y.32 /27	10.X.Y.33 - 10.X.Y+2.62
2	Wired Admin Users	10.X.Y.64 /27	10.X.Y.65 - 10.X.Y+3.94
212	Admin Wireless	10.X.Y.96 /27	10.X.Y.97 - 10.X.Y+4.126
211	Instructional Wireless	10.X.Y.128 /25	10.X.Y.129 - 10.X.Y+5.254
470	IPDVS	10.X.Y+1.0 /27	10.X.Y+1.1 - 10.X.Y+1.30

## Network Component General Configurations

### Medium, and Large Schools

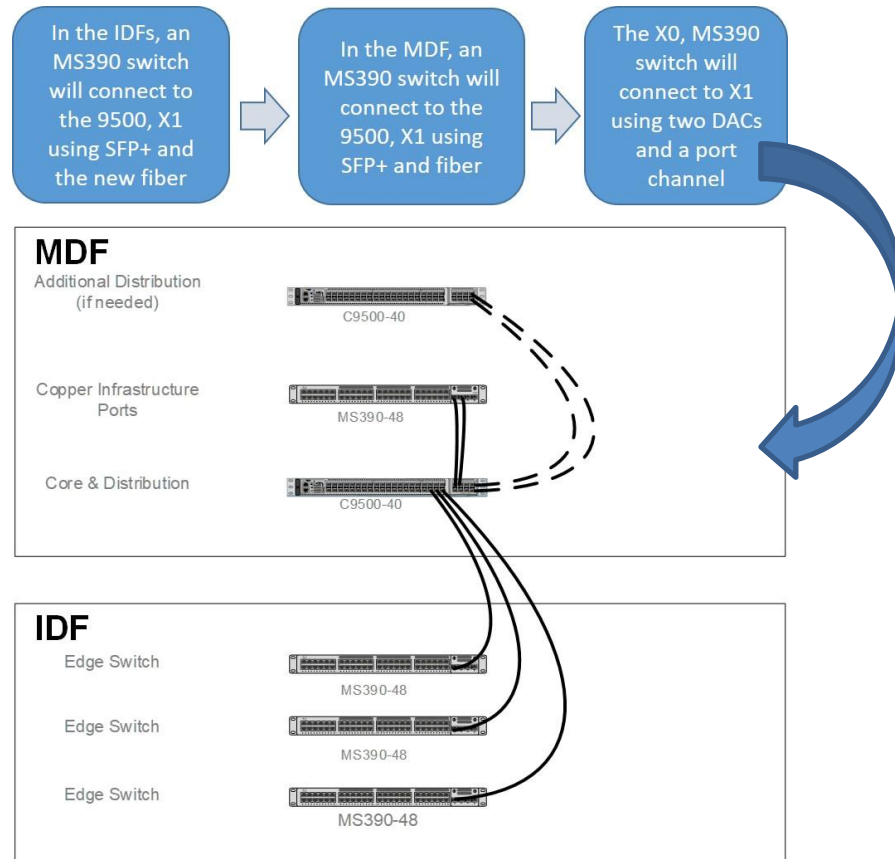

Figure D3: Physical Connectivity

### Standard School Edge Switch Port Assignments

The edge switches have converged usage. Many types of devices connect to them. These devices include PCs, printers, IPDVS cameras, Wireless Access Points, and any other devices needing Ethernet ports.

The standard edge switch is the Meraki MS390. It provides 48 x 100/1000/5000 Mbps switchports and 8 x 10Gbps uplink ports. It will provide up to 645 Watts of POE power. Therefore, up to 24 devices using 25 watts or less can be connected.

The patching is arranged so that the Wireless Access Points are on the right (starting at port 48 and working down). All other devices begin at the left and work up from port 1.

The newest generation of access points draw up to 30 watts per port. No more than 16 APs and 24 total POE devices (including APs and any other POE equipment) should be plugged into a single switch due to POE power budget limitations of 645W per switch. Evenly split the Access Points, as well as other POE devices between the switches in a particular IDF.

Before adding POE devices to a switch, check that switch's current power usage to make sure that the switch has sufficient power capacity. If not enough power is available on an IDF switch, another switch should be installed. All POE devices can be installed on any port of the switch. Access Points will be connected to ports 25 – 48 starting at the last port and continue backward.

The router provides wide area network (WAN) connectivity via the EVPL link provided by Crown Castle and connects to the terminal server (C1100), and core switch (C9500). Network traffic over the WAN link is routed through the Cisco 8300. Designated ports are shown in Table D3.

**Table D3: 8300 Router Port Assignments**

Port	Connected To	Notes
GigabitEthernet0/0/0	EVPL	Two sub-interfaces
GigabitEthernet0/0/1	Reserved	
GigabitEthernet0/0/2	Reserved	
GigabitEthernet0/0/3	C1100 Terminal Server	Static IP
TenGigabitEthernet0/0/4	X1 C9500 Core Switch	Static IP
TenGigabitEthernet0/0/5	Reserved (EVPL – 10G connection)	Two sub-interfaces

The edge switches all connect to the C9500 fiber core switch(es) using a single LC-LC (OM4) fiber cable. Network traffic between the 8300 and core switch is routed using OSPF. Designated port assignments for the C9500 core switch are in Table D5 and D6

**Table D4: Medium and Large School Core Switch Fiber Port Assignments (X1-A)**

Port	Connected To	VLAN
TwentyFiveGigE1/0/1	Layer 2 Switch X2	Trunk
TwentyFiveGigE1/0/2	Layer 2 Switch X3	Trunk
TwentyFiveGigE1/0/3	Layer 2 Switch X4	Trunk
TwentyFiveGigE1/0/4	Layer 2 Switch X5	Trunk
TwentyFiveGigE1/0/5	Layer 2 Switch X6	Trunk
TwentyFiveGigE1/0/6	Layer 2 Switch X7	Trunk
TwentyFiveGigE1/0/7	Layer 2 Switch X8	Trunk
TwentyFiveGigE1/0/8	Layer 2 Switch X9	Trunk
TwentyFiveGigE1/0/9	Layer 2 Switch X10	Trunk
TwentyFiveGigE1/0/10	Layer 2 Switch X11	Trunk
TwentyFiveGigE1/0/11	Layer 2 Switch X12	Trunk
TwentyFiveGigE1/0/12	Layer 2 Switch X13	Trunk
TwentyFiveGigE1/0/13	Layer 2 Switch X14	Trunk
TwentyFiveGigE1/0/14	Layer 2 Switch X15	Trunk
TwentyFiveGigE1/0/15	Layer 2 Switch X16	Trunk
TwentyFiveGigE1/0/16	Layer 2 Switch X17	Trunk
TwentyFiveGigE1/0/17	Layer 2 Switch X18	Trunk
TwentyFiveGigE1/0/18	Layer 2 Switch X19	Trunk
TwentyFiveGigE1/0/19	Layer 2 Switch X20	Trunk
TwentyFiveGigE1/0/20	Layer 2 Switch X21	Trunk
TwentyFiveGigE1/0/21	Layer 2 Switch X22	Trunk
TwentyFiveGigE1/0/22	Layer 2 Switch X23	Trunk
TwentyFiveGigE1/0/23	Layer 2 Switch X24	Trunk
TwentyFiveGigE1/0/24	Layer 2 Switch X25	Trunk
TwentyFiveGigE1/0/25	Layer 2 Switch X26	Trunk
TwentyFiveGigE1/0/26	Layer 2 Switch X27	Trunk
TwentyFiveGigE1/0/27	Layer 2 Switch X28	Trunk
TwentyFiveGigE1/0/28	Layer 2 Switch X29	Trunk

TwentyFiveGigE1/0/29	Layer 2 Switch X30	Trunk
TwentyFiveGigE1/0/30	Layer 2 Switch X31	Trunk
TwentyFiveGigE1/0/31	Layer 2 Switch X32	Trunk
TwentyFiveGigE1/0/32	Layer 2 Switch X33	Trunk
TwentyFiveGigE1/0/33	Layer 2 Switch X34	Trunk
TwentyFiveGigE1/0/34	Layer 2 Switch X35	Trunk
TwentyFiveGigE1/0/35	Layer 2 Switch X36	Trunk
TwentyFiveGigE1/0/36	Layer 2 Switch X37	Trunk
TwentyFiveGigE1/0/37	Layer 2 Switch X38	Trunk
TwentyFiveGigE1/0/38	Layer 2 Switch X39	Trunk
TwentyFiveGigE1/0/39	Layer 2 Switch X40	Trunk
TwentyFiveGigE1/0/40	Reserved	Trunk
TwentyFiveGigE1/0/41	Reserved	Trunk
TwentyFiveGigE1/0/42	Reserved	Trunk
TwentyFiveGigE1/0/43	Reserved	Trunk
TwentyFiveGigE1/0/44	Reserved	Trunk
TwentyFiveGigE1/0/45	Reserved	Trunk
TwentyFiveGigE1/0/46	Router Te0/0/4	3
TwentyFiveGigE1/0/47	X0 Te1/1/1	Trunk
TwentyFiveGigE1/0/48	X0 Te1/1/2	Trunk
HundredGigE1/0/49	X1-B HundredGigE1/0/49	Trunk
HundredGigE1/0/50	X1-B HundredGigE1/0/50	Trunk
HundredGigE1/0/51	Reserved	Trunk
HundredGigE1/0/52	Reserved	Trunk

**Table D5: Large School Core Switch Fiber Port Assignments (X1-B)**

Port	Connected To	VLAN
TwentyFiveGigE1/0/1	Layer 2 Switch X41	Trunk
TwentyFiveGigE1/0/2	Layer 2 Switch X42	Trunk
TwentyFiveGigE1/0/3	Layer 2 Switch X43	Trunk
TwentyFiveGigE1/0/4	Layer 2 Switch X44	Trunk
TwentyFiveGigE1/0/5	Layer 2 Switch X45	Trunk
TwentyFiveGigE1/0/6	Layer 2 Switch X46	Trunk
TwentyFiveGigE1/0/7	Layer 2 Switch X47	Trunk
TwentyFiveGigE1/0/8	Layer 2 Switch X48	Trunk
TwentyFiveGigE1/0/9	Layer 2 Switch X49	Trunk
TwentyFiveGigE1/0/10	Layer 2 Switch X50	Trunk
TwentyFiveGigE1/0/11	Layer 2 Switch X51	Trunk
TwentyFiveGigE1/0/12	Layer 2 Switch X52	Trunk
TwentyFiveGigE1/0/13	Layer 2 Switch X53	Trunk
TwentyFiveGigE1/0/14	Layer 2 Switch X54	Trunk
TwentyFiveGigE1/0/15	Layer 2 Switch X55	Trunk
TwentyFiveGigE1/0/16	Layer 2 Switch X56	Trunk
TwentyFiveGigE1/0/17	Layer 2 Switch X57	Trunk
TwentyFiveGigE1/0/18	Layer 2 Switch X58	Trunk
TwentyFiveGigE1/0/19	Layer 2 Switch X59	Trunk
TwentyFiveGigE1/0/20	Layer 2 Switch X60	Trunk
TwentyFiveGigE1/0/21	Layer 2 Switch X61	Trunk
TwentyFiveGigE1/0/22	Layer 2 Switch X62	Trunk
TwentyFiveGigE1/0/23	Layer 2 Switch X63	Trunk
TwentyFiveGigE1/0/24	Layer 2 Switch X64	Trunk

TwentyFiveGigE1/0/25	Layer 2 Switch X65	Trunk
TwentyFiveGigE1/0/26	Layer 2 Switch X67	Trunk
TwentyFiveGigE1/0/27	Layer 2 Switch X68	Trunk
TwentyFiveGigE1/0/28	Layer 2 Switch X69	Trunk
TwentyFiveGigE1/0/29	Layer 2 Switch X70	Trunk
TwentyFiveGigE1/0/30	Layer 2 Switch X71	Trunk
TwentyFiveGigE1/0/31	Layer 2 Switch X72	Trunk
TwentyFiveGigE1/0/32	Layer 2 Switch X73	Trunk
TwentyFiveGigE1/0/33	Layer 2 Switch X74	Trunk
TwentyFiveGigE1/0/34	Layer 2 Switch X75	Trunk
TwentyFiveGigE1/0/35	Layer 2 Switch X76	Trunk
TwentyFiveGigE1/0/36	Layer 2 Switch X77	Trunk
TwentyFiveGigE1/0/37	Layer 2 Switch X78	Trunk
TwentyFiveGigE1/0/38	Layer 2 Switch X79	Trunk
TwentyFiveGigE1/0/39	Layer 2 Switch X80	Trunk
TwentyFiveGigE1/0/40	Reserved	Trunk
TwentyFiveGigE1/0/41	Reserved	Trunk
TwentyFiveGigE1/0/42	Reserved	Trunk
TwentyFiveGigE1/0/43	Reserved	Trunk
TwentyFiveGigE1/0/44	Reserved	Trunk
TwentyFiveGigE1/0/45	Reserved	Trunk
TwentyFiveGigE1/0/46	Reserved	Trunk
TwentyFiveGigE1/0/47	Reserved	Trunk
TwentyFiveGigE1/0/48	Reserved	Trunk
HundredGigE1/0/49	X1-A HundredGigE1/0/49	Trunk
HundredGigE1/0/50	X1-A HundredGigE1/0/50	Trunk
HundredGigE1/0/51	Reserved	Trunk
HundredGigE1/0/52	Reserved	Trunk

**Table D6: Medium and Large School Core Switch Port Assignments (X0)**

Port	Connected Device	VLAN	SGT
1	Reserved		
2	Reserved		
3	Reserved		
4	Reserved		
5	Reserved		
6	Reserved		
7	Reserved		
8	Reserved		
9	Server 1 IMM	1	INFRA_SERVERS_LOCAL
10	Server 1 Hypervisor	1	INFRA_SERVERS_LOCAL
11	Server 1 Admin	2	ADMIN
12	Server 1 WireShark		
13	Server 1 Universal	1	INFRA_SERVERS_LOCAL
14	Server 2 IMM	1	INFRA_SERVERS_LOCAL
15	Server 2 Hypervisor	1	INFRA_SERVERS_LOCAL
16	Server 2 Admin	2	ADMIN
17	Server 2 WireShark		
18	Server 2 Universal	1	INFRA_SERVERS_LOCAL
19	Reserved		
20	CDR	412	IOT_NO_CLOUD
21	PBX Maintenance (Legacy)	412	IOT_NO_CLOUD
22	LonWorks	411	IOT_WITH_CLOUD

23	Legacy ISE or ClearPass	1	IOT_WITH_CLOUD
24	IPDVS Server 1	412	IOT_IPDVS
25	IPDVS Server 1 RSA	412	IOT_IPDVS
26	IPDVS Server 2	412	IOT_IPDVS
27	IPDVS Server 2 RSA	412	IOT_IPDVS
28	IPDVS UPS 1	412	IOT_IPDVS
29	IPDVS UPS 2	412	IOT_IPDVS
30	Apple Cache Server	211	INSTRUCTIONAL
31	Apple Cache Server	211	INSTRUCTIONAL
32	Apple Cache Server	211	INSTRUCTIONAL
33	Apple Cache Server	211	INSTRUCTIONAL
34	Apple Cache Server	211	INSTRUCTIONAL
35	Apple Cache Server	211	INSTRUCTIONAL
36	Apple Cache Server	211	INSTRUCTIONAL
37	Apple Cache Server	211	INSTRUCTIONAL
38	Reserved		
39	Admin Domain Controller	2	ADMIN
40	Instructional Domain Controller	211	INSTRUCTIONAL
41	Instructional Domain Controller	211	INSTRUCTIONAL
42	Reserved		
43	5G / DIA	7	DIA
44	Reserved		
45	Legacy IPDVS Server 1	412	IOT_IPDVS
46	Legacy IPDVS Server 2	412	IOT_IPDVS
47	Legacy ProCon Server Failover NIC		IOT_IPDVS
48	Legacy ProCon Server IMM / RSA		IOT_IPDVS
MA-MOD-8X10G_1	X1 TwentyFiveGigE1/0/47	Trunk	
MA-MOD-8X10G_2	X1 TwentyFiveGigE1/0/48	Trunk	
MA-MOD-8X10G_3	Reserved		
MA-MOD-8X10G_4	Reserved		
MA-MOD-8X10G_5	Legacy WLC	Trunk	
MA-MOD-8X10G_6	Legacy WLC	Trunk	
MA-MOD-8X10G_7	Reserved		
MA-MOD-8X10G_8	Reserved		

### Device Patching Diagrams

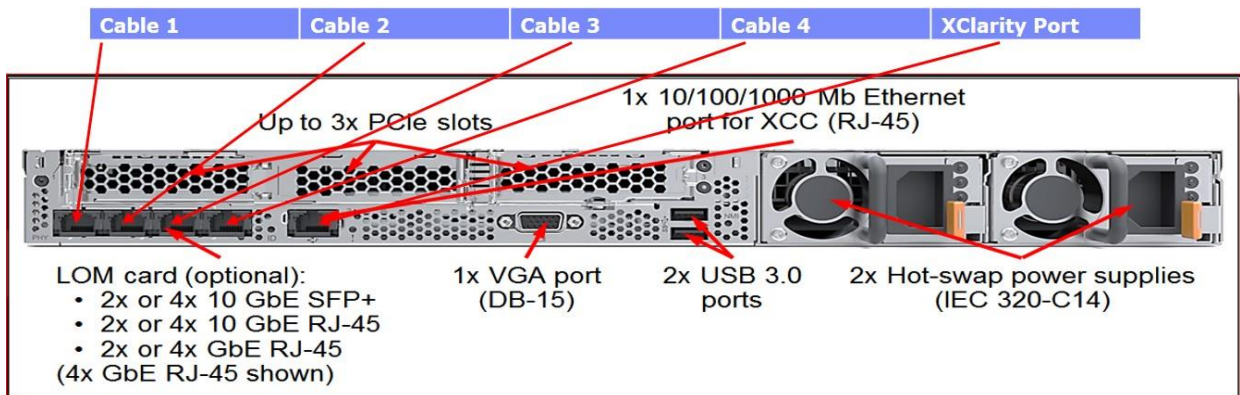
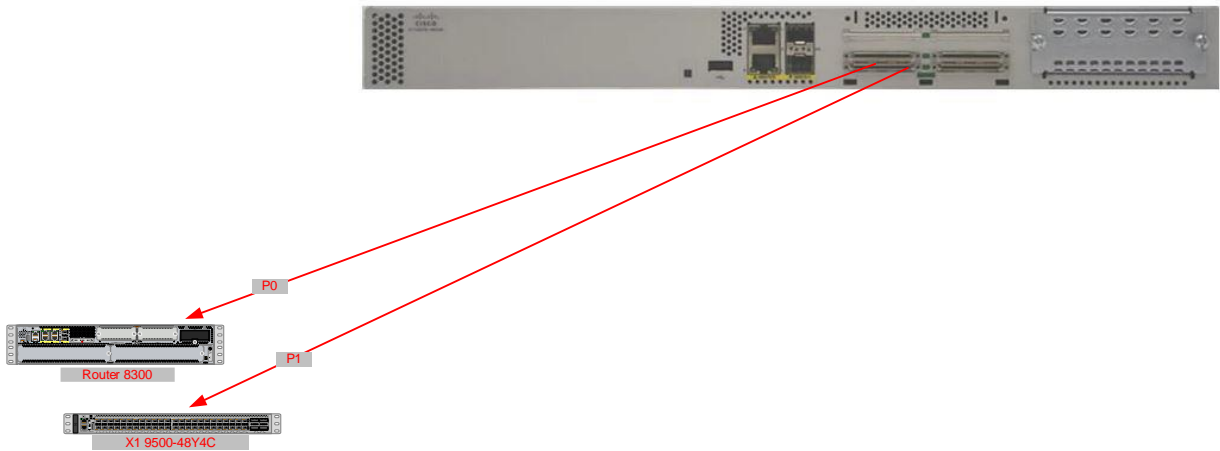

Figure D4: School Server



**Figure D5: Cisco 1100 TSG Async to console**

**Note: Async connections go to router, core switch (X1), and all non-Meraki switches in the MDF.**

**Table D7: Small-School ISR 1111 and 9300-24 Port Assignments**

CISCO ISR 1111 ROUTER		
INTERFACE	POE/NON-POE	WHAT TO CONNECT
Interface GigabitEthernet0	POE+	Wireless Access Point
Interface GigabitEthernet1	POE+	Wireless Access Point
Interface GigabitEthernet2	POE+	Wireless Access Point
Interface GigabitEthernet3	POE+	Wireless Access Point
Interface GigabitEthernet4	Non-POE	IDF Switch/9300-24
Interface GigabitEthernet5	Non-POE	IDF Switch/9300-24
Interface GigabitEthernet6	Non-POE	IDF Switch/9300-24
Interface GigabitEthernet7	Non-POE	EVC Metro Ethernet
Interface GigabitEthernet8	Non-POE	Not being used
Interface GigabitEthernet0/0/0	Non-POE	EVPL/Cable or FIOS Modem
Interface GigabitEthernet0/0/1	Non-POE	Not being used
CISCO 9300-24 SWITCH		
INTERFACE	POE/NON-POE	WHAT TO CONNECT
G1/0/1	Cisco ISR 1111 Router	Trunk
G1/0/2 - 20	Non-Access Points	10
G1/0/21 - 24	Wireless Access Points	100

## Network Component Summary

### School Standard Site with MDF and IDF Components

The components for the Standard Schools are listed in Table D8 below. The MDF cabinet houses a Cisco router, a Cisco 9500 and MS390 Switch, and a Windows 2019 Lenovo Server. The IDF cabinet houses Cisco MS390 switches. There may be an access points connected to some or all of the MS390 switches.

**Table D8: Medium/Large School Components**

Function	Devices in MDF & IDF
Core Switch	C9500-48Y4C-EDU (Medium, and Large schools)
Edge Switch	MS390-48UX2-HW (IDF)
Wireless Controller	N/A
Access Point	MR57-HW
Router	C8300-2N2S-4T2X
Firewall	None
DHCP Server	Lenovo SR630

### Small School

The components for the Small and Full Admin Charter schools are listed in Table D13 below. The MDF (which in some small remote sites may be the office, instead) has a cabinet that houses a Cisco ISR 1111 Router, a Cisco 9300-24 switch and a MR57 Access Point.

**Table D9: Small School Components**

Function	Device in MDF/IDF
Router	C1111-8PWB
Switch	C9300-24P
Access Point	MR57-HW

**Note:** Stickers with asset tag and serial number information should be placed on the side of the equipment where visible when installed in an open rack. Stickers should be placed on the bottom toward the front of the equipment when installed in a closed cabinet.

## ***Component Naming Conventions***

Standardized naming conventions are required on a per school basis. User, group, workstation, printer, and server names must be unique within a school's network. New Active Directory servers and domains must subscribe to the naming convention below. However, schools with existing Active Directory domains are not required to change workstation or server names within those domains. The following guideline outlines naming of the various components that would be placed on the school network.

### Guidelines

Domains:

Active Directory Root Domain:

DOE School ID.nycboe.org (e.g. 23B123 = 23B123.nycboe.org)

Active Directory Subdomains:

Subdomain NYCDOE School ID.nycboe.org (e.g. admin.23B123.nycboe.org)

NT Domain Name:

DOE School ID (e.g. 23B123)

Servers:

Network Infrastructure Server:

DOE School ID + Server Type + Sequence Number

Example: 23B123 + Server + 001 = 23B123S001

**Note:** All Network Infrastructure Server names will be the School ID + S001

Active Directory Domain Controller:

DOE School ID + DC + Sequence Number

Example: 23B123 + DC + 01 = 23B123DC01

(Optional/Recommended)

School/Region Provided Server Name:

DOE School ID + Server Type + Room Number + Server Type Sequence Number

Computer Types:

**L** = School/Region provided Lab Server

**C** = School/Region provided Classroom Server

**R** = Regional Center provided Server

**A** = School/Region provided Administrative Server

**S** = NYCDOE/DIIT provided Server  
**ADM** = NYCDOE/DIIT Administrative VM for NOC on VLAN2  
**INS** = NYCDOE/DIIT Instructional VM for NOC on VLAN1  
**NME** = NYCDOE/DIIT Network Access Management VM for NOC  
**CAP** = NYCDOE/DIIT Data capture VM for NOC  
**HOST01** = NYCDOE/DIIT Hyper-V host [Primary Server]  
**HOST02** = NYCDOE/DIIT Hyper-V host [Secondary Server]

### Examples

**Example #1:** A school has two (2) labs with 2 servers in each lab. In addition, it has a server for faculty/administrators. Classroom Connect is installing a Network Infrastructure server. Server names would be as follows:

Classroom Connect Network Infrastructure Server: 23B041S001

Faculty/Administrators server: 23B041A001

Lab in Room 312 - Server #1 23B041L312001

Lab in Room 312 – Server #2 23B041L312002

Lab in Room 112 – Server #1 23B041L112001

Lab in Room 112 – Server #2 23B041L112002

**Example #2:** A school is configured with a Classroom Connect Network Infrastructure server and a school provided Active Directory Server. Server names would be as follows:

Classroom Connect Network Infrastructure Server: 23B123S001

School Active Directory Server: 23B123DC01

School Active Directory Domain: 23B123.nycboe.org

School Hyper-V host [Primary Server]: 23B123-HOST01

School Hyper-V host [Secondary Server]: 23B123-HOST02

School Administrative VM for NOC on VLAN2: 23B123-ADM

School Instructional VM for NOC on VLAN1: 23B123-INS

School Network Access Management for NOC: 23B123-NME

School Data Capture for NOC: 23B123-CAP

**Note:** While the above naming convention is recommended, regions and schools may wish to develop their own district/school-provided server naming convention. It is important to remember that all school and region owned servers, within the school network, must be unique.

### Workstations

Computer Name: Computer manufacturer's serial number of the CPU.

Workgroup Name: NYCDOE School ID.

Description: NYCDOE School ID + Classroom/Lab Location

Using the CPU serial number simplifies identifying the computer during helpdesk calls since it is required by the helpdesk when reporting problems. It also eliminates the need for constant renaming when computers are moved between classrooms or schools, or when computers are replaced or swapped. Using the serial number also guarantees uniqueness.

Note: It is important that all workstations within a district have a unique computer name. In the event that two computers have the same computer name, the second computer logging on will receive an error that a computer with the same name is already on the network and will be denied services.

### Printers

The following naming convention is required when using Windows printer queues:

Using the printer serial number simplifies identifying the printer during helpdesk calls since the helpdesk requires it when reporting problems. It also eliminates the need for constant renaming when printers are moved between classrooms or schools, or when printers are replaced. Using the serial number also guarantees uniqueness.

Printer Name: Printer manufacturer's serial number.

Description: Printer Type + NYCDOE school ID + Classroom/Lab Location

Example: Lexmark4908 23B041 RM312

Example: HP3Si 23B041 RM210

## ***Equipment Heat Dissipation and Power Requirements***

Schools continue to require additional technology infrastructure to support the needs of teachers, students and administrators. As the technology footprint grows, additional environmental resources are required to meet the physical requirements of the infrastructure hardware. One of these resources is HVAC. As new infrastructure components are added, additional cooling may be required to ensure that all components operate within manufacturer specified parameters. This section, with associated tables below, identifies the cooling requirements of each MDF component.

### PDU Port Assignments

Core Cabinet			
PDU #1	Used For	PDU #2	Used For
Outlet #1	Router	Outlet #1	Router
Outlet #2	Core Switch X1	Outlet #2	Core Switch X1
Outlet #3	Core Switch X0	Outlet #3	Core Switch X0
Outlet #4	Server #1	Outlet #4	Server #1
Outlet #5	Terminal Server	Outlet #5	
Outlet #6		Outlet #6	
Outlet #7	Leave Empty	Outlet #7	Leave Empty
Outlet #8	Leave Empty	Outlet #8	Leave Empty

Outlet #9	Leave Empty	Outlet #9	Leave Empty
Outlet #10	Leave Empty	Outlet #10	Leave Empty

Access Cabinet/Rack			
PDU #1	Used For	PDU #2	Used For
Outlet #1	Access Switch X2	Outlet #1	Access Switch X2
Outlet #2	Access Switch X3	Outlet #2	Access Switch X3
Outlet #3	Access Switch X4	Outlet #3	Access Switch X4
Outlet #4	Access Switch X5	Outlet #4	Access Switch X5
Outlet #5	Access Switch X6	Outlet #5	Access Switch X6
Outlet #6	Access Switch X7	Outlet #6	Access Switch X7
Outlet #7	Leave Empty	Outlet #7	Leave Empty
Outlet #8	Leave Empty	Outlet #8	Leave Empty
Outlet #9	Leave Empty	Outlet #9	Leave Empty
Outlet #10	Leave Empty	Outlet #10	Leave Empty

Medium/Large Schools

**Table D10: Typical Power**

Device	Note	Power Supplies	BTUs (Expected)	Watts (Expected)	BTUs (MAX)	Watts (MAX)
UPS			300		300	
C9500-48	Standard X1	dual 650W	680	200	4420	1300
MS390	X0	dual 1100W	680	200	7480	2200
MS390*	With 15 POE devices	1100W			7480	2200
Catalyst 8300	Router	650	2210	650	2210	650
Lenovo Server	1 server	2 x 550 Watt	3751	2 x 550	3751	1100
PBX						
Voicemail						

\*if the switches plug into a quad then they should not exceed four access switches and/or 40 access points.

**Table D11: Typical Cooling**

	150 s.f. MDF			300 s.f. MDF		
	Watts	Watts	BTUs	Watts	Watts	BTUs
	(Max)	(Expected)	(Expected)	(Max)	(Expected)	(Expected)
<b>C9500-48Y4C</b>	1300	200	680	1300	200	680
<b>Meraki MS390-48UX2 Infrastructure</b>	2200	200	680	2200	200	680

2 Meraki MS390-48UX2 w 15 devices	2200	400	1360			
3 Meraki MS390-48UX2 w 15 devices				3300	600	2040
C8300-2N2S	650	650	2210	650	650	2210
C1100TG-1N32A (terminal server)	80	30	102	80	30	102
Lenovo SR630 School Server	1500	500	1700	1500	500	1700
Belkin KVM with Monitor	48	48	163.2	48	48	163.2
Lenovo SR650 IPDVS Server	1600	550	1100	1600	550	1100
Mitel 3300		220	750		220	750
Mitel 7100 MAP AP		220	750		220	750
HP POE Phone Switch	710	500	1700	710	500	1700
Technician's PC		150	510		150	510
NuPoint Server		150	510		150	510
APC 3000 for Voice			552			552
APC 3000 for IPDVS			552			552
<b>Total</b>			<b>18,984</b>			<b>21,047</b>

DFS & ATS Charter Schools

**Table D12**

Expected	
Device	BTU
C1111-8PWB	426
<b>Totals</b>	<b>426</b>

Small School

**Table D13**

Maximum			
Device	BTU (Expected)	Quantity	Subtotals
C1111-8PWB	426	1	426
C9300-24P	800	1	800
MR57-HW	167	1	167
<b>Totals</b>			<b>593</b>

## High Capacity Rooms

Rooms with a large number of wired connections that have a small cabinet, housing one (or two) switches, do not need an L6-30 outlet or PDU installed. Examples of this are computer labs. Below is a table to show what is needed.

Number of Switches	Outlet(s)	Cabinet
1 x Access Switch	1 x quad (5-20R)	AR106V
2 x Access Switches	2 x quad (5-20R)	AR106V
3 or more Access Switches	2 x Single (L6-30R)	CWR-12-32PD

## Integrating Legacy Devices

The Standards Document intends to describe entirely new networks. However, there are many situations where we must integrate new equipment with older equipment and mix different generations of standards. This section describes how to handle different scenarios.

### Router

An older model WAN router (CISCO3640, CISCO3745, CISCO3845, CISCO2951, or CISCO4461) should always be replaced with a Catalyst 8300 router. WAN circuits no longer terminate at the core switch. The router provides WAN connectivity. A separate ISR 1100 router provides Out-of-Band Management using ASYNC connectivity. If the router will be connected to a new switch, the standard configuration will be correct. However, if the new router is being connected to a legacy switch, the switchport configuration on that switch may need to be changed. The switchport should be configured as mode access using switchport access VLAN 3.

### X0

If the X0 (previously called X66) switch needs replacement, the new switch should be an MS390-48UX2-HW. If the core switch is a C9500-48Y4C-EDU, X0 should be a MS390-48UX2-HW and connect to it via a pair of DAC/TWINAX cables. If the core switch is a C6880-X-LE, X0 should be a WS-C2960X-48FPD-L and connect to it via a pair of DAC/TWINAX cables.

### Edge Switches

Sometimes core hardware (Router, X1, X0, etc.) will be refreshed but the edge switches will not. If an edge switch is refreshed, the switch model is MS390-48UX2-HW. If 2960 and 9300 switches are too new to remove, they can remain on the network. However, they are not interchangeable with the new Meraki switches. We cannot connect to the 9500 core switch (X1) because it does not have Meraki Security Group Tags (SGTs).

If there are any legacy switches that cannot be removed from the network (2960 or 9300), it must be connected to an MS390 via the uplink ports. They must connect using SFP transceivers and fiber cables. New configurations will be applied to the legacy switches after their new connections are completed. All connections on the legacy switch must be migrated onto the MS390. If any connections remain on the legacy switch, it cannot be an access point and they must all be on the same VLAN.

We cannot assign SGTs to the older switches, however, all ports will use the SGT for the uplink. So all ports on a 2960 can be used for an office, computer lab, library, etc. No Access Points, Cybershift clocks, etc. can be connected to these switches. All copper ports will receive the same access as provided by the SGT on the uplink. If a 2960 must stay on the network, please follow these guidelines:

- It must connect to a Meraki MS390 starting from port 8 of the uplink module.
- There is a maximum of two legacy switches allowed to connect to a Meraki MS390 switch.
- Move as many connections from the legacy switch to the Meraki MS390 switch.
- Any DAC connecting two legacy switches to each other must be disconnected

#### Wireless Controllers

If wireless controllers are being refreshed, do not replace them. Wireless Access Points are now controlled through the cloud and communicate through the WAN connections. If a legacy wireless controller will not be refreshed but the core switch will be refreshed, connect the controller to the new MS390-48UX2-HW core switch X0.

#### Procon Server

The Procon server's replacement is now a single server. If a Procon server requires a refresh, replace with a single server. Again, no site should receive more than one server. Connect the server to X0 via copper RJ45 patch cords.

#### When extra Fiber capacity is needed

If a 6880 switch is installed in a school and is not slated for refresh but the sites needs more fiber capacity there is a standard configuration.

## **MDF Designs**

There are three standard MDF Designs. The school building size determined the MDF Design. The Voice and Data Cabling Standards provide much more information.

**Table D14: Small Schools**

<b>Network Model</b>	<b>Criteria</b>
Small-School Site	<ul style="list-style-type: none"><li>• Less than 40 students</li><li>• No Phone system</li></ul>

### Small School

The Small School MDF design does not need a dedicated room. Based on the minimal network equipment requirements, a smaller rack/cabinet will suffice. The following parameters are key attributes and requirements that apply to Small Schools:

1) Requires a small cabinet located where it:

- Is away from students
- Is protected from the outdoors
- Is near cable / DSL outlet
- Is protected from water
- Has sufficient airflow (no cooling required)
- Has sufficient power
  - single quad (5-20R)
- Is secure
- Is grounded

2) Cabinet specifications:

- Inside height: 10 to 24 Rack Units (RU)
- Inside rack Width: Standard 19 inches between vertical rails.
- Inside depth: Allows 19 inches depth.
- Example = APC AR100HD with AR8105BLK shelf (or shelves).
- Table D19 below highlights the Data Equipment which will be mounted in the Small School cabinet:

**Table D15 – Small-School Data Equipment**

Function	Device	Ht.	Quantity	Total Ht.
EVPL/ Cable / FIOS Modem	Provided by ISP	1 RU	1	1
Core Switch / Router	C1111-8PWB	1 RU	1	1
Edge Switch	C9300-24P	1 RU	1	1
<b>TOTAL</b>				<b>3 RU</b>

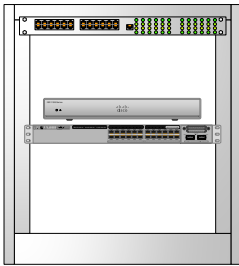

EVPL MRV

Cisco ISR 1111 Router  
Cisco 9300-24 Switch

**Figure D6: MDF Rack in Small or Full Admin Charter School Site**

**Note:** Due to its minimal network component requirements and anticipated room constraints, Small or Charter schools will likely use a cabinet or enclosure from 10U to 13U in height. The cabinet should allow for components at least 24 inches deep. Below is an example, the APC AR100HD.



## School Rack Elevation

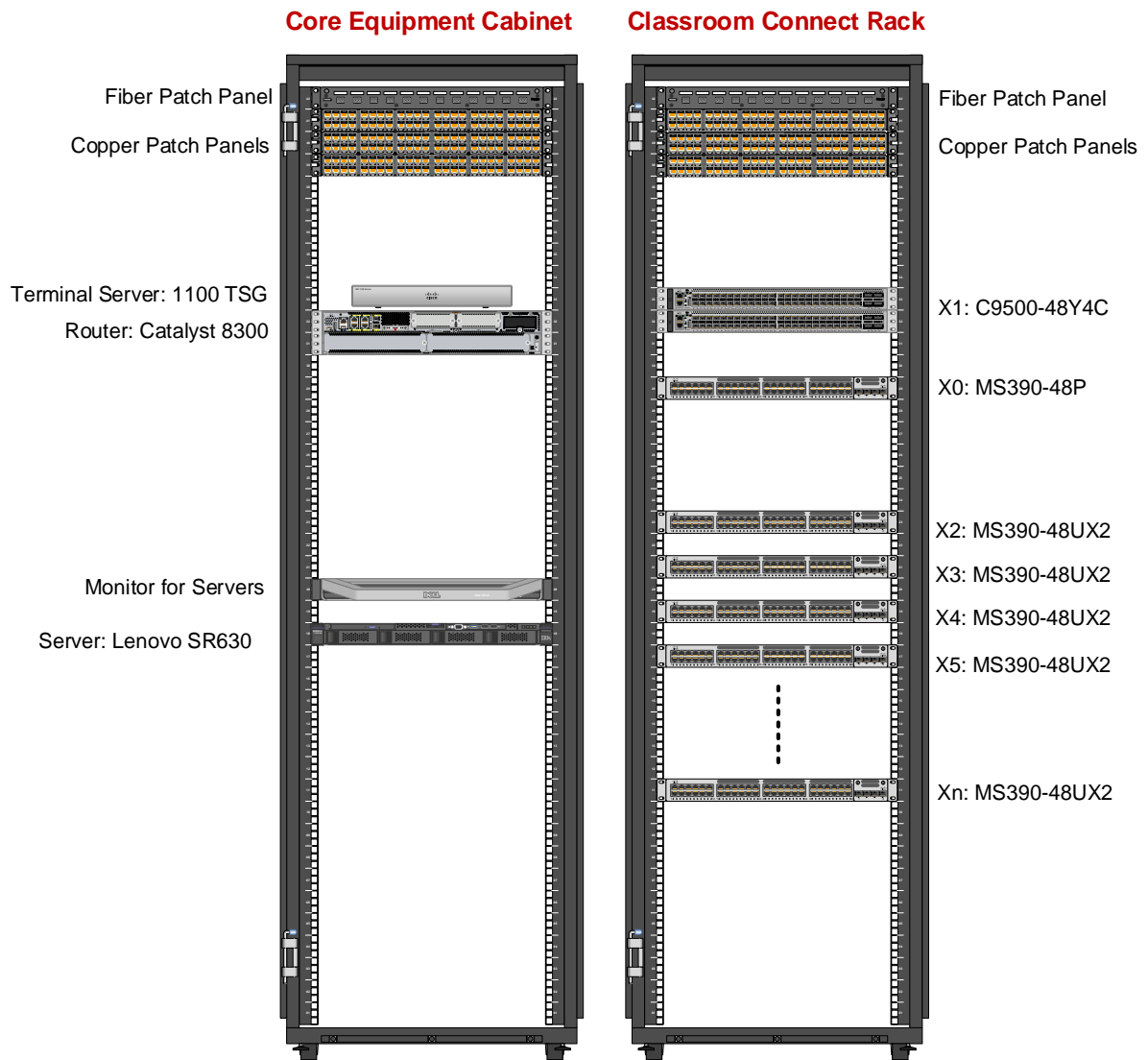

**Figure D7: Medium & Large School Cabling / New Construction MDF Data Rack Elevation**

The MDF Designs are an essential part of this standards document, providing both guidance and granular specifics in addressing the needs of all new/existing NYCDOE schools. Three general school models will be referenced in this section; Small (<40 students), Medium (<1000 students), and Large (>=1000) students schools. Table 2-1 above specifies the key criteria.

### Equipment Cabinet

The server for Standard Sites will be housed in a forty-two unit (73.5 ") core network cabinet installed in the Main Telecommunication Room or MDF. For Small and Charter Schools, a much smaller cabinet is used. For other sites, the cabinet should measure 73 1/8" high by 29" wide by 42" deep. See Appendix D for the list of components with associated product numbers required for Small, Medium, and Large School sites. The standard model cabinet is an APC (American Power Conversion) NetShelter cabinet.

*The equipment cabinet is provided with a surge arrest, providing catastrophic event protection, always-on outlets, cord management and site wiring fault indication for the rack-mounted equipment including the Server and WAN router. Additionally, the surge arrest provides a fast-acting fuse that reacts instantaneously to lightning strikes and other spikes. A thermal fuse shuts the equipment down safely in the event of a wiring fault.*

### Network Surge Arrest

The network surge arrest provides catastrophic event protection, always-on outlets, cord management and site wiring fault indication for the rack-mounted equipment including the Network Infrastructure Server and WAN router. Additionally, the surge arrest provides a fast-acting fuse that reacts instantaneously to lightning strikes and other spikes. A thermal fuse shuts the equipment down safely in the event of a wiring fault.

### Medium School MDF

The following parameters are key attributes and requirements which apply to sites with more than 40 students (but less than 1,000) as it relates to the MDF **whose minimum size should measure 150 square feet:**

#### 1) Medium School Cabinet Specifications:

- APC APC-AR3150
- The Data cabinet will have up to two PDUs – Model AP9571A
- The Voice rack will not have power strips
- The cabinets should be ordered with cable management Each cabinet should receive
  - a. Four horizontal cable management such as AR8426A
  - b. Cable management rings in the front on the cabinet such as AR7540
  - c. Vertical cable management such as a pair of AR8442 for the power cords in the back

#### 2) Medium School Cabinet & Rack parameters:

- One cabinet will be installed for Data – two if capacity is needed
- The two cabinets will be the same model

- The cabinets' dimensions will be approximately 29" wide by 42" deep by 80" tall
- The cabinets and racks will be securely bolted to the floor and grounded
- The two cabinets and the rack will be installed in a row
- Patch panels for data drops will be installed in the top of the data cabinet
- Cabinets and racks will be installed so the front faces the door
- The front of the cabinets should be at least 3 feet from the wall
- 3 feet clearance should be left between the cabinet and the side wall
- The installation should follow the drawing as closely as possible
- At least 24,000 BTU cooling will be provided where deployed
- Ladder Rack installed above cabinets and rack
- Electrical outlets installed on side of Ladder Rack
- Ladder Rack is grounded to common ground
- Ladder rack extends from wall to edge of cabinet furthest from the wall
- Floor Plan Figure D11 below highlights the aforementioned particulars:

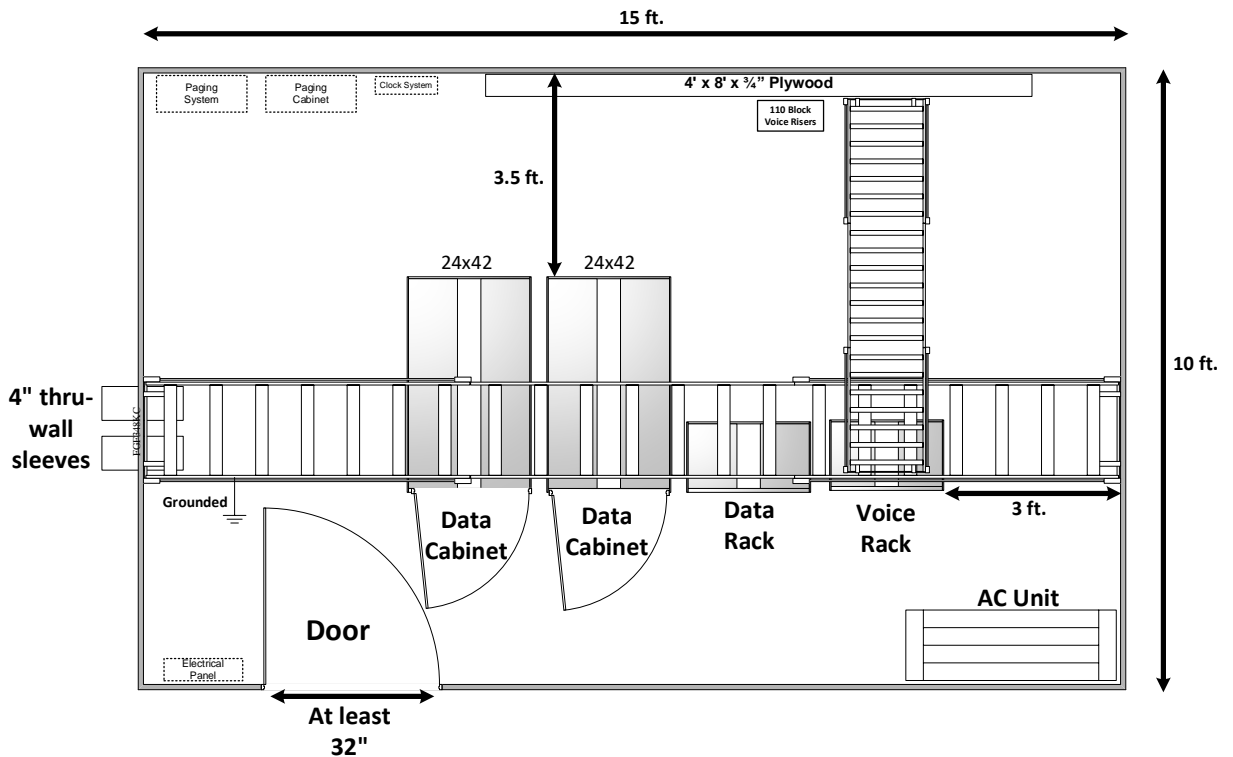

**Figure D8: Sample Medium/Large School MDF**

3) Voice rack:

- The Voice rack will be a 19" 2-post rack as described in the Cabling Standards Document
- The 2-post rack will be bolted securely to the floor and grounded
- The Voice rack will be ordered without a power strip
- The Voice rack will be ordered with cable management
- Patch panels for phone jacks will be installed at the top of the rack
- 3 x 3 foot plywood will be installed on a wall adjacent and perpendicular to the rack for Voice cross-connects and Quad 5-20R outlets

4) Electrical Outlet specifics:

- The outlets for Data should be installed above the Data cabinet
- Two of the L6-30 outlets should be connected to PDUs in the data cabinet
- The outlets for Voice should be installed above the Voice rack
- The outlets for the AV cabinet should installed above it
- Circuit requirements are specified in Table D20 and Figure D12 below:

**Table D16 – Medium School Electric Outlets**

Volts / Amps	Outlets	IPDVS	Data	Core Switch	Voice	Plywood
110v / 20 Amp	single (5-20R)					
110v / 20 Amp	duplex (5-20R)				1	
110v / 20 Amp	quad (5-20R)	2				1
110v / 30 Amp	Single (L5-30R)	1				
220v / 30 Amp	Single (L6-30R)		2	2	1	

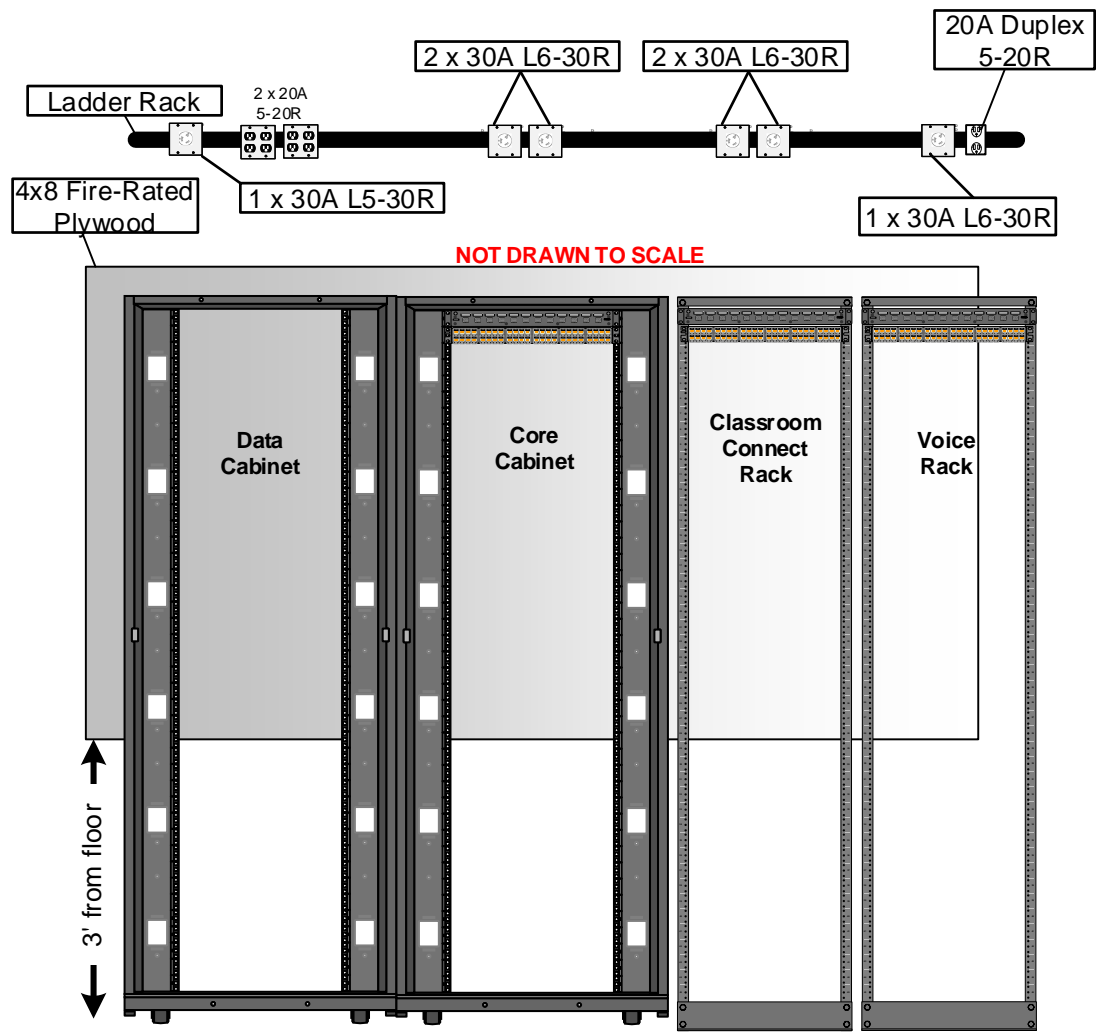

**Figure D9: Medium School MDF Cabling**

Table D22 below highlights the Data Equipment, which will be mounted in the Medium School Data cabinet:

**Table D17 – Medium School MDF Data Equipment**

Function	Device	Ht.	Quantity	Total Ht.
Core Switch	C9500-48Y4C-EDU	1 RU	1	1
Infrastructure Switch	MS390-48UX2-HW	1 RU	1	1
Edge Switch	MS390-48UX2-HW	1 RU	Varied	1
Terminal Server	C1100TG-1N32A	1 RU	1	1
Router	CISCO C8300-2N2S-4T2X	2 RU	1	2
DHCP Server	Lenovo SR630	1 RU	1	1
KVM	Belkin KVM with Monitor	1 RU	1	1
<b>TOTAL</b>				<b>8 RU</b>

### Large School Sites

The following parameters are key attributes and requirements which apply Schools with 15 or more classrooms:

#### 1) Large School MDF Design:

- Should measure at least 300 sq. ft.
- Is dedicated as a single-purpose room
- May house any combination of a telephone, LAN/WAN, Telco, video surveillance, and various building alarm systems
- Area dry, and at or above ground level (not in the basement or cellar or on the top floor or roof)
- Accessible for wiring to and from the IDF
- Should house entrance facilities and demarcation points for the telecommunications systems and WAN
- Is tightly controlled via a non-master key or access control card reader.
- Interconnected with all other telecommunications rooms with minimum of two (2) 3-inch conduit assemblies meeting TIA/EIA- 569-A.
- Located to minimize the number of IDFs, but not violate 100 meter Ethernet limitations to drops
- Located to not violate the 300 meter 50/125 micron OM3 limitations to IDFs.
- Contains three 42U open racks and one 42U equipment cabinet with appropriate vertical cable management between each rack.
- Racks and cabinets should be aligned side-by-side as shown in Figure D13 below:

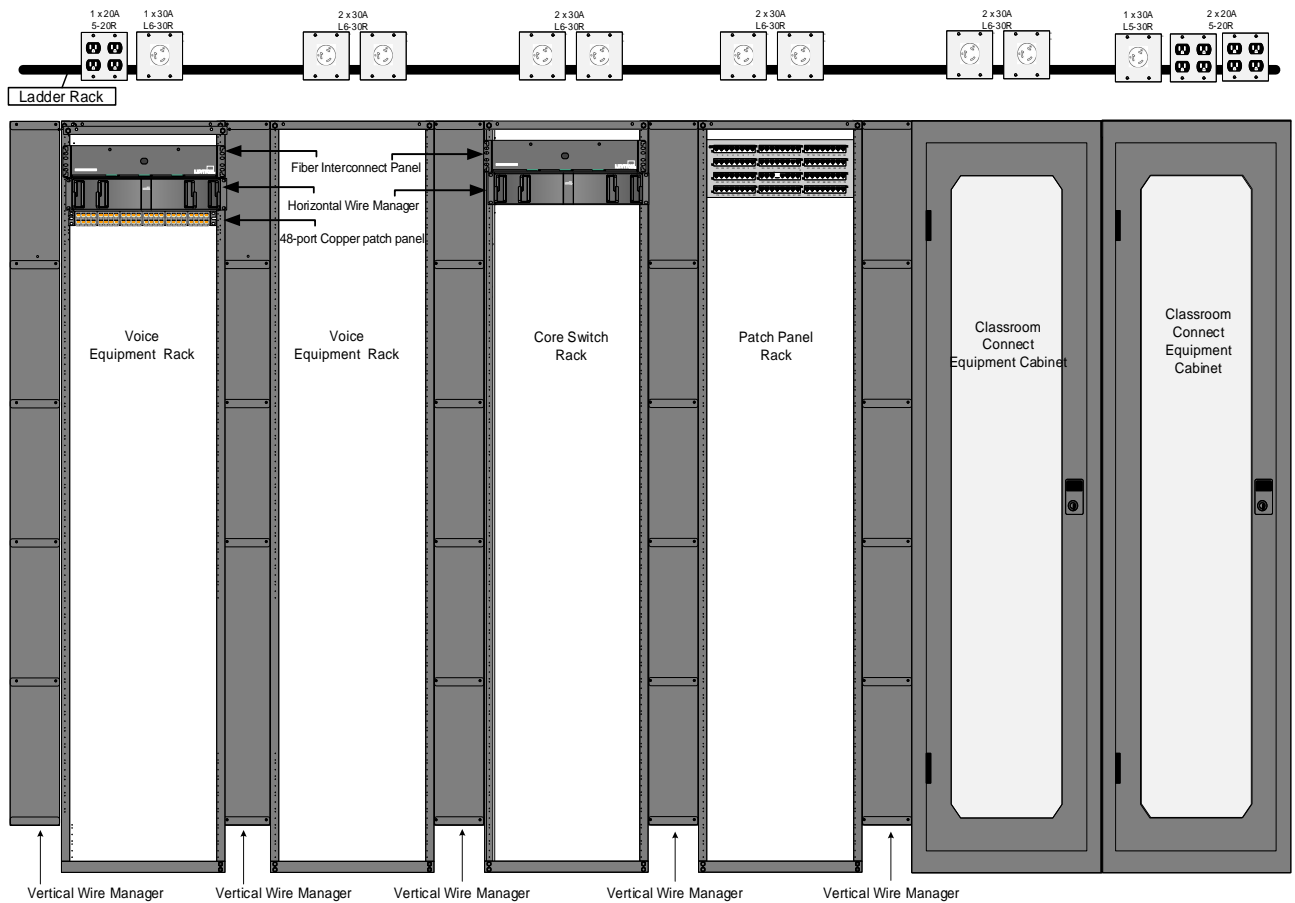

**Figure D10: Large School racks, cabinets, and outlets**

2) Large School Cabinets and Racks:

- The cabinets' dimensions will be approximately 29" wide by 42" deep by 80" tall
- The racks will be standard 19" 2-post racks with wire management
- Two L6-30 outlets per rack/cabinet are for the PDUs (AP9571A) to plug in the core devices and other network hardware.
- The cabinets and racks will be securely bolted to the floor and grounded
- The cabinets and the racks will be installed in a row
- Cabinets and racks will be installed so the fronts faces the door
- Cabinets and racks will be installed so that doors can be fully opened and both front and back are easily accessible
- At least 36,000 BTU of cooling will be provided
- The installation should follow the drawing as closely as possible
- Ladder Rack should be installed above cabinets and rack
- Ladder Rack is grounded to common ground

- Ladder rack extends from wall to edge of cabinet furthest from the wall
- Should follow existing standards of Voice/Data Cable Infrastructure Specifications for Patch Panel and Plywood installations
- Table D23 below highlights the Data Equipment which will be mounted in the Large School Data cabinet:
  - Schools with more than 40 access switches will need a second X1 core switch

**Table D18 – Large School MDF Data Equipment**

Function	Device	Ht.	Quantity	Total Ht.
Core Switch	C9500-48Y4C-A-CAP	1 RU	1	1
Infrastructure Switch	MS390-48UX2-HW	1 RU	1	1
Edge Switch	MS390-48UX2-HW	1 RU	Varied	1
Terminal Server	C1100TG-1N32A	1 RU	1	1
Router	CISCO C8300-2N2S-4T2X	2 RU	1	2
DHCP Server	Lenovo SR630	1 RU	1	1
KVM	Belkin KVM with Monitor	1 RU	1	1
<b>TOTAL</b>				<b>8 RU</b>

3) Electrical Outlet specifics:

- The outlets for each rack or cabinets should be mounted on the wall directly behind their respective racks and cabinets
- Circuit requirements are specified in Table D23 below:

**Table D19 - Large School Electric Outlets**

Volts / Amps	Outlets	Voice	Core Switch	Patch Panel	Class. Conn.	IPDVS	Plywood
110v / 20 Amp	single (5-20R)						
110v / 20 Amp	duplex (5-20R)						
110v / 20 Amp	quad (5-20R)	1				2	1
110v / 30 Amp	Single (L5-30R)					1	
220v / 30 Amp	Single (L6-30R)	1	2	2	2		

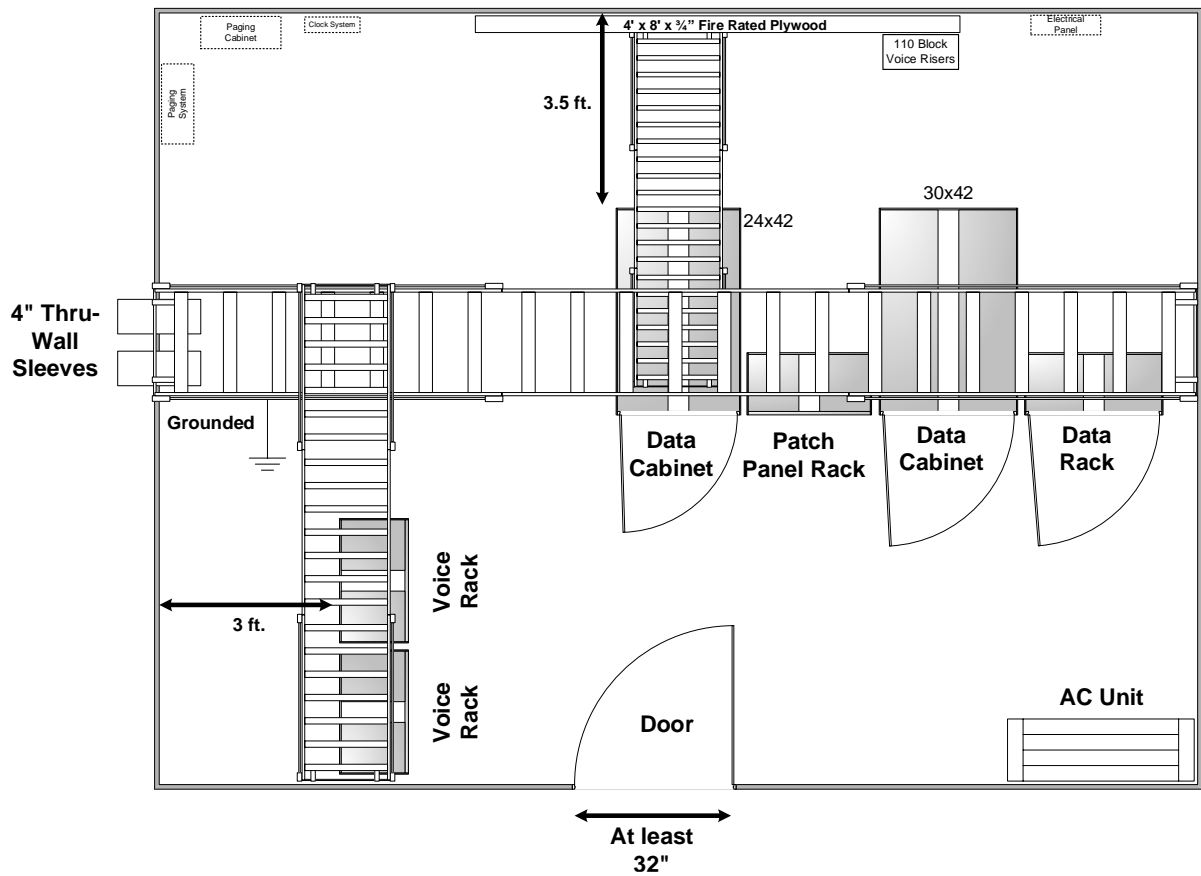

**Figure D11: Sample Large School MDF**

### ***IDF Designs***

The IDF designs for Medium and Large schools are the same. Small Schools' IDFs will differ since they rarely have a room dedicated for an MDF or for an IDF.

The Intermediate Telecommunications Rooms (or Intermediate Distribution Facilities (IDF)) are single purpose rooms that are minimally 100-sq. ft. When choosing locations for new IDFs, they should be placed dedicated rooms without water/wash facilities. In addition to meeting foot print requirements, the location should have enough space, power capacity and HVAC to support infrastructure expansion.

If wall mount cabinets are to be used, they are to be mounted, at most, 3 feet from the floor. If multiple Intermediate Telecommunication Rooms are utilized, stacked rooms or rooms located above each other are preferred. Ideally, horizontal Unshielded Twisted Pair (UTP) cables should be designed to run no more than 220 feet horizontally, measured from the IDF patch panel to the end-point/termination/jack. Consideration should be given for future expansion of telecommunication spaces and other systems without the need to assign new rooms for equipment. Adhering to industry standards for sizing IDFs based upon square footage of service area is recommended.

### **Medium/Large School IDF**

Currently, there is a data rack in each IDF Room in a school. We wish to provide the room with a second rack to support voice equipment, and to provide enough space to walk around these two racks. Precise dimensions and interior placement will vary by school. The actual configurations of both IDF racks vary from school to school, depending upon the needs of a particular building.

There is a 24-fiber interconnect panel terminating at the top of the data rack riser termination. The IDF data rack contains 48-port patch panels and switches. These devices support both wired and wireless equipment (e.g., desktop computers, printers, wireless access points, etc.). Switches supporting wireless equipment must provide in-line power. The number of patch panels and switches will vary by school, and scale in direct proportion to the number of devices that must be supported. Fiber-optic cable connects the IDF data switches to the MDF.

There is a 24-fiber interconnect panel terminating at the top of the voice rack riser termination. The IDF voice rack will contain 48 port patch panels and various configurations of voice switches. In the case of a Medium, or Large high school, the rack may also include voice server equipment. The number of patch panels and switches will vary by IDF, school, and scale in direct proportion to the number of devices that must be supported.

Table D24 below highlights the Data equipment which will be mounted in the IDF Data cabinet:

**Table D20 – Medium, and Large-School IDF Data Equipment**

Function	Device	Ht.	Quantity	Total Ht.
Edge Switch	MS390-48UX2-HW	1 RU	Varied	1
<b>TOTAL</b>				<b>1 RU</b>

#### Power Requirements:

- 3) Two quads, dedicated, 20-amp A/C receptacles (type 5-20R), located at least two feet apart must be provided within three (3) feet of the cabinet in all Intermediate Telecommunications Room. Two (2) single 220V 30 Amp (L6-30) circuits will be installed. Each will be connected to a PDU for the rack.
- 4) The PBX system shall be provided with a wall mounted surge protector that meets UL 1449 specifications. It shall protect (with automatic reset) connected equipment against transient surges and noise, delivering heavy-duty transient clamping within 5 nanoseconds with EMI/RFI filtering from 50dB attenuation at 340KHz. Peripheral equipment (e.g. call accounting systems and MAT terminals) should be similarly protected.

**Table D21 – Electrical Outlets**

Volts / Amps	Outlets	IPDVS	Voice	Patch Panel	Class. Conn.
110v / 20 Amp	quad (5-20R)	2	1	0	0
220V / 30 Amp	Single (L6-30)	0	0	0	2

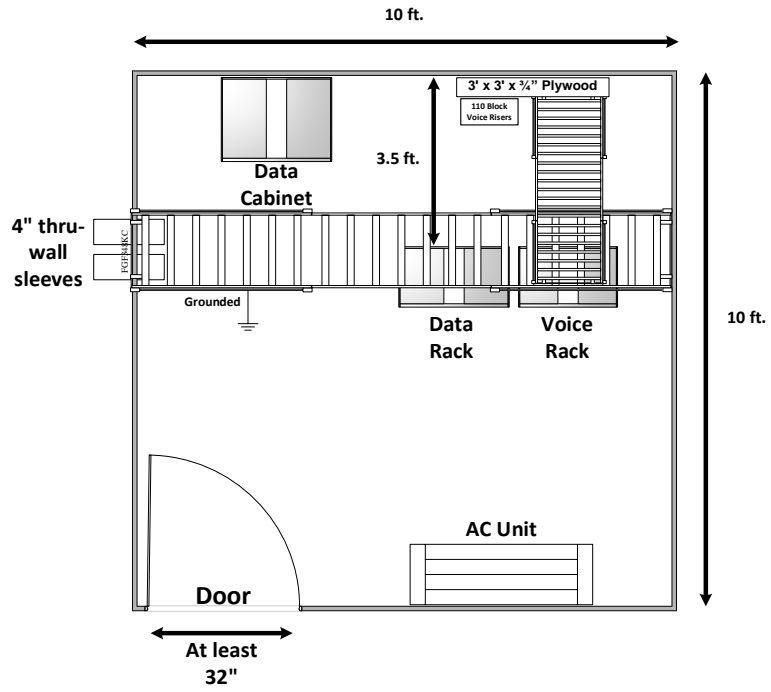
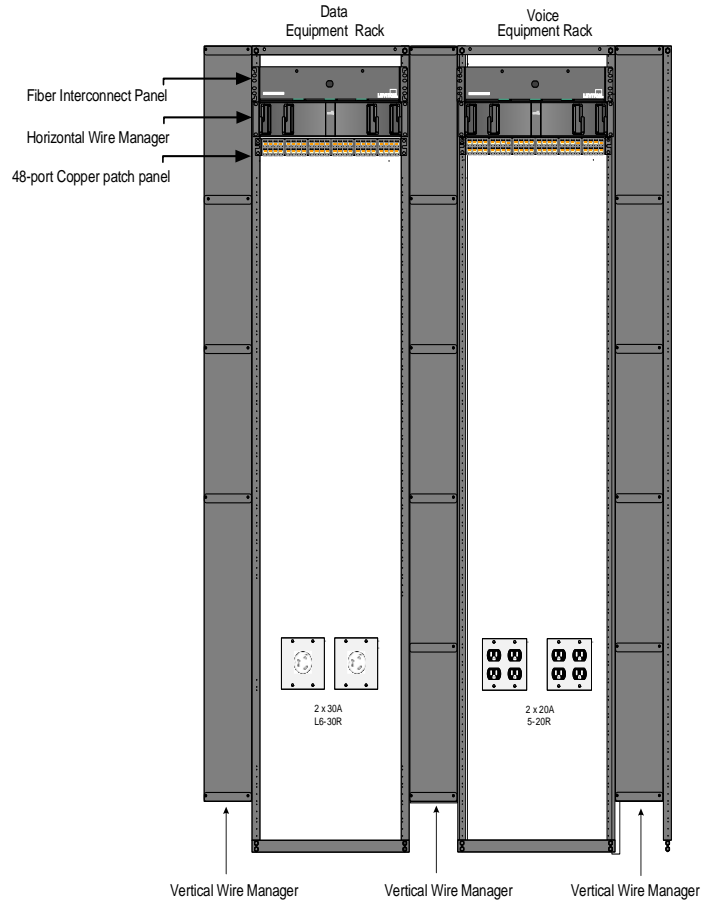

Figure D12: Sample Medium/Large School IDF



**Figure D13: IDF Data and Voice Racks**

### ***Unmanaged Switches***

There are times that a school may need a small number of additional ports. However, it is not feasible to have the new runs installed. Examples may include:

- Principal's Office where one additional port is needed for a printer
- Library with many PCs

FAMIS has small, unmanaged switches but in situations like this, please follow the following guidelines:

1. during the sight survey, plan to add more data drops.
2. if data drops are not able to be added to the room, plan for a Cisco Switch to be installed in a central location (inside a cabinet) in the room.
3. plan to use the wireless network available at the school instead of plugging into a data drop.

An unmanaged switch is not supported by DIIT if/when problems arise concerning connectivity to those non-standard devices. The following devices should not be connected:

1. routers
2. non-standard access points

Some models may not be compatible with Meraki Switches. Some may require further configurations on the network to make them work. Daisy chaining and multiple uplinks are not supported.

The larger switches should be configured to DIIT standards. Please contact Engineering Support for assistance with the configuration.

### Software Versions

**Table D22 – Current School Hardware**

Device	Model	Code	Notes
C9500 Core Switch (X1)	C9500-48Y4C	cat9k_iosxe.17.03.04.SPA.bin	
Terminal Server	C1100TG-1N32A	c1100tg-universalk9.17.03.05.SPA.bin	

**Table D23 – Older School Hardware**

Device	Model	Code	Notes
ISR 4461 Router	ISR4461/K9	isr4400v2-universalk9.16.09.04.SPA.bin	
C9300 Core Switch (X66)	C9300-48UXM	cat9k_iosxe.16.09.04.SPA.bin	
Firewall	FPR2110-ASA-K9	cisco-asa-fp2k.9.13.2.SPA	
Firewall	FPR2130-ASA-K9	cisco-asa-fp2k.9.13.2.SPA	
C9300L Edge Switch	C9300L-48UXG4X	cat9k_iosxe.16.12.02.SPA.bin	
Terminal Server	ISR4221/K9	isr4200-universalk9_ias.16.06.06.SPA.bin	
C6880 Core Switch	C6880-X-LE	c6880x-ipervicesk9-mz.SPA.152-1.SY5.bin	X1
Mini-School X1 & Charter Router	C897VAW-A-K9	c800-universalk9-mz.SPA.153-3.M3.bin	Mini-School X1
2960 L2 Switch	WS-C2960X-48FPD-L	c2960x-universalk9-mz.152-4.E8.bin	Used for POE & non-POE devices
2612 Router	CISCO2612	c2600-is-mz.120-7.T.bin	
2811 Admin R2	CISCO2811	c2800nm-ipbase-mz.123-8.T11.bin	
2811 Charter School R1	CISCO2811	c2800nm-entbase-mz.123-8.T11.bin	
3845 Router	Cisco3845	c3845-entbasek9-mz.151-4.M12a.bin	
2951 Router	CISCO2951/K9	c2951-universalk9-mz.SPA.151-2.T1.bin	
4351 Router	CISCO4351	isr4300-universalk9.16.06.06.SPA.bin	
3560 V2 XR1	WS-C3560V2-48TS-E	c3560-ipervicesk9-mz.122-53.SE2.bin	X1 Only

Firewall	ASA5510-SEC-BUN-K9	asa724-k8.bin	
Firewall	ASA5515-K9	asa861-smp-k8.bin	asdm version asdm-66114.bin
Firewall	ASA5516-K9	asa944-6-lfbff-k8.SPA	
Firewall	ASA5555-K9	asa861-smp-k8.bin	
Access Point	AIR-LAP1262N-A-K9	ap3g1-rcvk9w8-tar.124-23c.JA2.tar	
Wireless LAN Controller	C1-AIR-CT5520-K9	AIR-CT5520-K9-8-5-140-0.aes	
	AIR-CT5508-K9	172 WLC: 7.4.140.0 167 WLC: 7.0.116.0 56 WLC: 7.3.112.0	
Wireless Controller	Aruba 7210 Controller	6.4.2.10	
Wireless LAN Controller	C1-AIR-CT5520-K9	AIR-CT5520-K9-8-5-140-0.aes	
	Aruba 7010 Controller	6.4.2.10	

## Appendix E – School Network Component BOMs

### Components for Large School

**Table E1: Large SDWAN Router**

Part	Description	Quantity
<b>C8300-2N2S-4T2X</b>	Cisco Catalyst C8300-2N2S-4T2X Router	1
CON-SNT-C8302TNX	SNTC-8X5XNBD Cisco Catalyst C8300	1
MEM-C8300-16GB	Cisco Catalyst 8300 Edge 16GB memory	1
M2USB-16G	Cisco Catalyst 8000 Edge M.2 USB 16GB	1
C-RFID-2R	Cisco Catalyst 8000 Edge RFID - 2RU	1
C8300-RM-19-2R	Cisco Catalyst 8300 Rack mount kit - 19" 2R	1
C8300-NIM-BLANK	Cisco Catalyst 8300 Edge NIM Blank	2
C8300-SM-BLANK	Cisco Catalyst 8300 Edge SM Blank	2
C8300-PIM-BLANK	Cisco Catalyst 8300 Edge PIM Blank	1
C8300-FAN-2R	Cisco Catalyst 8300 Edge Fan Tray, 2RU	1
NETWORK-PNP-LIC	Network Plug-n-Play Connect for zero-touch device deployment	1
C-POE-COVER	Cover for empty POE slot on Cisco Catalyst Edge 8300	2
PWR-CC1-650WAC	Cisco C8300 2RU AC Power supply	2
C8000-HSEC	U.S. Export Restriction Compliance license for C8000 series	1
CAB-C13-C14-2M	Power Cord Jumper, C13-C14 Connectors, 2 Meter Length	2
SC8KBEUK9-175	UNIVERSAL	1
IOSXE-CTRL-MODE	IOS XE SD-WAN boot up mode for Unified image	1

**Table E2: SDWAN Tier 3 License**

Part	Description	Quantity
<b>L-DNA-C8300</b>	Cisco DNA Subscription for Catalyst 8300 Series	1
C83-2N2S-4T2X-PF	C8300-2N2S-4T2X Platform Selection for DNA Subscription	1
SDWAN-UMB-ADV	Cisco Umbrella for DNA Advantage	1
DNA-HSEC-ACK	Acknowledge to procure the HSEC license with the Hardware	1
IOSXE-CTRL-MODE-PF	IOS XE SD-WAN boot up mode for Unified image - Deployment Opt	1
SVS-CDNA-ADV	Embedded Support for SW - Tiered DNA Advantage Cloud	1
SDWAN-CLOUD-PF	Cisco SDWAN Cloud Deployment Option	1
DNA-C-T3-A-3Y	Cisco DNA Advantage Cloud Lic 3Y - upto 10G (Aggr, 20G)	1
DSTACK-T3-A	Cisco DNA Advantage Stack - upto 10G (Aggr, 20G)	1
NWSTACK-T3-A	Cisco Network Advantage Stack - upto 10G (Aggr, 20G)	1

**Table E3: 10G Optic (connect R1 to X1)**

Part Number	Description	Quantity
SFP-10G-SR	10GBASE-SR SFP Module, Enterprise-Class	3

**Table E4: Core Switch X1**

Part Number	Description	Quantity
C9500-48Y4C-EDU	Catalyst 9500 48-port x 1/10/25G and 4-port 40/100G , EDU	1
C9500-NW-A	C9500 Network Stack, Advantage	1
C9K-F1-SSD-240G	Cisco pluggable SSD storage	1
C9K-PWR-650WAC-R	650W AC Config 4 Power Supply front to back cooling	1
C9K-PWR-650WAC-R/2	650W AC Config 4 Power Supply front to back cooling	1
CAB-9K12A-NA	Power Cord, 125VAC 13A NEMA 5-15 Plug, North America	2
C9K-T1-FANTRAY	Catalyst 9500 Type 4 front to back cooling Fan	2
C9500-DNA-48Y4C-A	C9500 DNA Advantage, Term License	1
C9500-DNA-A-3Y	Cisco Catalyst 9500 DNA Advantage 3 Year License	1
PI-LFAS-T	Prime Infrastructure Lifecycle & Assurance Term - Smart Lic	3
PI-LFAS-AP-T-3Y	PI Dev Lic for Lifecycle & Assurance Term 3Y	3
NETWORK-PNP-LIC	Network Plug-n-Play Connect for zero-touch device deployment	1
SC9500HUK9-175	Cisco Catalyst 9500H XE.17.5 UNIVERSAL	1
CAB-C13-C14-2M=	Power Cord Jumper, C13-C14 Connectors, 2 Meter Length	2

**Table E5: Second Core Switch X1-B (if needed)**

Part Number	Description	Quantity
C9500-48Y4C-EDU	Catalyst 9500 48-port x 1/10/25G and 4-port 40/100G , EDU	1
C9500-NW-A	C9500 Network Stack, Advantage	1
C9K-F1-SSD-240G	Cisco pluggable SSD storage	1
C9K-PWR-650WAC-R	650W AC Config 4 Power Supply front to back cooling	1
C9K-PWR-650WAC-R/2	650W AC Config 4 Power Supply front to back cooling	1
CAB-9K12A-NA	Power Cord, 125VAC 13A NEMA 5-15 Plug, North America	2
C9K-T1-FANTRAY	Catalyst 9500 Type 4 front to back cooling Fan	2
C9500-DNA-48Y4C-A	C9500 DNA Advantage, Term License	1
C9500-DNA-A-3Y	Cisco Catalyst 9500 DNA Advantage 3 Year License	1
PI-LFAS-T	Prime Infrastructure Lifecycle & Assurance Term - Smart Lic	3
PI-LFAS-AP-T-3Y	PI Dev Lic for Lifecycle & Assurance Term 3Y	3
NETWORK-PNP-LIC	Network Plug-n-Play Connect for zero-touch device deployment	1
SC9500HUK9-175	Cisco Catalyst 9500H XE.17.5 UNIVERSAL	1
CAB-C13-C14-2M=	Power Cord Jumper, C13-C14 Connectors, 2 Meter Length	2

**Table E6: Two 100G Twinax to connect both core switches (order 2 of the 3M or 5M)**

Part Number	Description	Quantity
QSFP-100G-CU3M=	100GBASE-CR4 Passive Copper Cable, 3m	2
QSFP-100G-CU5M=	100GBASE-CR4 Passive Copper Cable, 5m	2

**Table E7: Expansion Switch for Core (X0)**

Part Number	Description	Quantity
MS390-48UX2-HW	Meraki MS390 48m5G L3 UPOE Switch	1
MA-PWR-1100WAC	Meraki MS390 1100W AC Power Supply	1
CAB-C15-CBN=	Cabinet Jumper Power Cord, 250 VAC 13A, C14-C15 Connector	2
MA-MOD-8X10G	Meraki MS390 8x10GE Module	1
LIC-MS390-48A-3Y	Meraki MS390 48-port Advanced License and Support, 3 Year	1

**Table E8: Twinax/DAC cables to connect X0 to X1**

Part Number	Description	Quantity
SFP-H10GB-CU1M=	10GBASE-CU SFP+ Cable 1 Meter	2
SFP-H10GB-CU3M=	10GBASE-CU SFP+ Cable 3 Meter	2
SFP-10G-SR-S=	10GBASE-SR SFP Module, Enterprise-Class	4

**Table E9: Access Switch for IDF**

Part Number	Description	Qty
MS390-48UX2-HW	Meraki MS390 48m5G L3 UPOE Switch	1
MA-PWR-1100WAC	Meraki MS390 1100W AC Power Supply	1
CAB-C15-CBN=	Cabinet Jumper Power Cord, 250 VAC 13A, C14-C15 Connector	2
MA-MOD-8X10G	Meraki MS390 8x10GE Module	1
LIC-MS390-48A-3Y	Meraki MS390 48-port Advanced License and Support, 3 Year	1

**Table E10: 10G optic SFPs (one for Xn and second for X1)**

Part Number	Description	Quantity
SFP-10G-SR-S=	10GBASE-SR SFP Module, Enterprise-Class	2

**Table E11: Terminal Server**

Part Number	Description	Quantity
<b>C1100TG-1N32A</b>	Cisco 1100 Terminal Gateway w/ 32 Async & 1 NIM	1
CON-SNT-C1100TG1	SNTC-8X5XNBD Cisco 1100 Terminal Gateway w/ 32 Async	1
SL-1100TG-IPB-K9	IP Base License for Cisco 1100 Series Terminal Gateway	1
PWR-1100TG-AC	AC Power Supply for Cisco 1100 Term Gateway	1
CAB-ASYNC-8	Async cable	2
C1100TG-BRA	Async Bracket for Cisco 1100TG	1
NIM-BLANK	Blank faceplate for NIM slot on Cisco ISR 4400	1
C1100TG-16A	16-port Async Module for Cisco 1100 Term Gateway	1
ACS1100TG-RM19	Rack Mount Kit for Cisco 1100TG	1
CAB-C13-C14-2M	Power Cord Jumper, C13-C14 Connectors, 2 Meter Length	1
SC1100TGUK9-174	Cisco 1100 Series Terminal Gateway IOS XE Universal	1

**Components for Medium School****Table E12: Medium Router**

Part Number	Description	Quantity
<b>C8300-2N2S-4T2X</b>	Cisco Catalyst C8300-2N2S-4T2X Router	1
CON-SNT-C8302TNX	SNTC-8X5XNBD Cisco Catalyst C8300	1
MEM-C8300-16GB	Cisco Catalyst 8300 Edge 16GB memory	1
M2USB-16G	Cisco Catalyst 8000 Edge M.2 USB 16GB	1
C-RFID-2R	Cisco Catalyst 8000 Edge RFID - 2RU	1
C8300-RM-19-2R	Cisco Catalyst 8300 Rack mount kit - 19" 2R	1
C8300-NIM-BLANK	Cisco Catalyst 8300 Edge NIM Blank	2
C8300-SM-BLANK	Cisco Catalyst 8300 Edge SM Blank	2
C8300-PIM-BLANK	Cisco Catalyst 8300 Edge PIM Blank	1
C8300-FAN-2R	Cisco Catalyst 8300 Edge Fan Tray, 2RU	1
NETWORK-PNP-LIC	Network Plug-n-Play Connect for zero-touch device deployment	1
C-POE-COVER	Cover for empty POE slot on Cisco Catalyst Edge 8300	2
PWR-CC1-650WAC	Cisco C8300 2RU AC Power supply	2
C8000-HSEC	U.S. Export Restriction Compliance license for C8000 series	1
CAB-C13-C14-2M	Power Cord Jumper, C13-C14 Connectors, 2 Meter Length	2
SC8KBEUK9-175	UNIVERSAL	1
IOSXE-CTRL-MODE	IOS XE SD-WAN boot up mode for Unified image	1

**Table E13: SDWAN Tier 2 License**

Part Number	Description	Quantity
<b>L-DNA-C8300</b>	Cisco DNA Subscription for Catalyst 8300 Series	1
C83-2N2S-4T2X-PF	C8300-2N2S-4T2X Platform Selection for DNA Subscription	1
SDWAN-UMB-ADV	Cisco Umbrella for DNA Advantage	1
DNA-HSEC-ACK	Acknowledge to procure the HSEC license with the Hardware	1
IOSXE-CTRL-MODE-PF	IOS XE SD-WAN boot up mode for Unified image -Deployment Opt	1
SVS-CDNA-ADV	Embedded Support for SW - Tiered DNA Advantage Cloud	1
SDWAN-CLOUD-PF	Cisco SDWAN Cloud Deployment Option	1
DNA-C-T2-A-3Y	Cisco DNA Advantage Cloud Lic 3Y - upto 1G (Aggr, 2G)	1
DSTACK-T2-A	Cisco DNA Advantage Stack - upto 1G (Aggr, 2G)	1
NWSTACK-T2-A	Cisco Network Advantage Stack - upto 1G (Aggr, 2G)	1

**Table E14: 10G Optic (connect R1 to X1)**

Part Number	Description	Quantity
<b>SFP-10G-SR</b>	10GBASE-SR SFP Module, Enterprise-Class	3

**Table E15: Core Switch X1**

Part Number	Description	Quantity
<b>C9500-48Y4C-EDU</b>	Catalyst 9500 48-port x 1/10/25G and 4-port 40/100G , EDU	1
C9500-NW-A	C9500 Network Stack, Advantage	1
C9K-F1-SSD-240G	Cisco pluggable SSD storage	1
C9K-PWR-650WAC-R	650W AC Config 4 Power Supply front to back cooling	1
C9K-PWR-650WAC-R/2	650W AC Config 4 Power Supply front to back cooling	1
CAB-9K12A-NA	Power Cord, 125VAC 13A NEMA 5-15 Plug, North America	2
C9K-T1-FANTRAY	Catalyst 9500 Type 4 front to back cooling Fan	2
C9500-DNA-48Y4C-A	C9500 DNA Advantage, Term License	1
C9500-DNA-A-3Y	Cisco Catalyst 9500 DNA Advantage 3 Year License	1
PI-LFAS-T	Prime Infrastructure Lifecycle & Assurance Term - Smart Lic	3
PI-LFAS-AP-T-3Y	PI Dev Lic for Lifecycle & Assurance Term 3Y	3
NETWORK-PNP-LIC	Network Plug-n-Play Connect for zero-touch device deployment	1
SC9500HUK9-175	Cisco Catalyst 9500H XE.17.5 UNIVERSAL	1
CAB-C13-C14-2M=	Power Cord Jumper, C13-C14 Connectors, 2 Meter Length	2

**Table E16: Expansion Switch for Core (X0)**

Part Number	Description	Quantity
<b>MS390-48UX2-HW</b>	Meraki MS390 48m5G L3 UPOE Switch	1
MA-PWR-1100WAC	Meraki MS390 1100W AC Power Supply	1
CAB-C15-CBN=	Cabinet Jumper Power Cord, 250 VAC 13A, C14-C15 Connector	2
MA-MOD-8X10G	Meraki MS390 8x10GE Module	1
LIC-MS390-48A-3Y	Meraki MS390 48-port Advanced License and Support, 3 Year	

**Table E17: Twinax/DAC cables to connect X0 to X1**

Part Number	Description	Quantity
<b>SFP-H10GB-CU1M=</b>	10GBASE-CU SFP+ Cable 1 Meter	2
<b>SFP-H10GB-CU3M=</b>	10GBASE-CU SFP+ Cable 3 Meter	2
<b>SFP-10G-SR-S=</b>	10GBASE-SR SFP Module, Enterprise-Class	4

**Table E18: Access Switch for IDF**

Part Number	Description	Qty
<b>MS390-48UX2-HW</b>	Meraki MS390 48m5G L3 UPOE Switch	1
MA-PWR-1100WAC	Meraki MS390 1100W AC Power Supply	1
CAB-C15-CBN=	Cabinet Jumper Power Cord, 250 VAC 13A, C14-C15 Connector	2
MA-MOD-8X10G	Meraki MS390 8x10GE Module	1
LIC-MS390-48A-3Y	Meraki MS390 48-port Advanced License and Support, 3 Year	1

**Table E19: 10G optic SFPs (one for Xn and second for X1)**

Part Number	Description	Quantity
<b>SFP-10G-SR-S=</b>	10GBASE-SR SFP Module, Enterprise-Class	2

**Table E21: Terminal Server**

Part Number	Description	Quantity
-------------	-------------	----------

<b>C1100TG-1N32A</b>	Cisco 1100 Terminal Gateway w/ 32 Async & 1 NIM	1
CON-SNT-C1100TG1	SNTC-8X5XNBD Cisco 1100 Terminal Gateway w/ 32 Async	1
SL-1100TG-IPB-K9	IP Base License for Cisco 1100 Series Terminal Gateway	1
PWR-1100TG-AC	AC Power Supply for Cisco 1100 Term Gateway	1
CAB-ASYNC-8	Async cable	2
C1100TG-BRA	Async Bracket for Cisco 1100TG	1
NIM-BLANK	Blank faceplate for NIM slot on Cisco ISR 4400	1
C1100TG-16A	16-port Async Module for Cisco 1100 Term Gateway	1
ACS1100TG-RM19	Rack Mount Kit for Cisco 1100TG	1
CAB-C13-C14-2M	Power Cord Jumper, C13-C14 Connectors, 2 Meter Length	1
SC1100TGUK9-174	Cisco 1100 Series Terminal Gateway IOS XE Universal	1

### ***Components for Wireless***

**Table E22: Access Point (for hallways and high density areas)**

<b>Part Number</b>	<b>Description</b>	<b>Quantity</b>
<b>MR46E-HW</b>	Meraki MR46E Wi-Fi 6 Indoor AP w External Antenna Connectors	1
MA-ANT-3-E6	Meraki Indoor Dual-band Wide Patch Ant, 6port MR46E/MR53E	1
MA-MNT-ANT-1	Meraki Standard Mounting Arm for E & F Series Patch Antenna	1
LIC-MR-ADV-3Y	Meraki MR Advanced License and Support, 3YR	1

**Table E23: Access Point (for classrooms)**

<b>Part Number</b>	<b>Description</b>	<b>Quantity</b>
<b>MR56-HW</b>	<b>Meraki MR56 Wi-Fi 6 Indoor AP</b>	1
LIC-MR-ADV-3Y	Meraki MR Advanced License and Support, 3YR	1

**Table E24: Access Point (for classrooms)**

<b>Part Number</b>	<b>Description</b>	<b>Quantity</b>
<b>MR57-HW</b>	<b>Meraki MR57 Wi-Fi 6E Indoor AP</b>	1
LIC-MR-ADV-3Y	Meraki MR Advanced License and Support, 3YR	1

**Table E25: Access Point (for outdoor w/ omni antennas)**

Part Number	Description	Quantity
<b>MR86-HW</b>	<b>Meraki MR86 Wi-Fi 6 Outdoor AP</b>	1
MA-ANT-20	Meraki Dual-band Omni Antennas	2
LIC-MR-ADV-3Y	Meraki MR Advanced License and Support, 3YR	1

**Table E26: Access Point (for outdoor)**

Part Number	Description	Quantity
<b>MR86-HW</b>	<b>Meraki MR86 Wi-Fi 6 Outdoor AP</b>	1
MA-ANT-25	Meraki Dual Band Patch Antenna	1
LIC-MR-ADV-3Y	Meraki MR Advanced License and Support, 3YR	1

***Components for Small School*****Table E27: Small Router**

Part Number	Description	Quantity
<b>C1111-8PWB</b>	<b>ISR 1100 8 Ports Dual GE Ethernet Router w/ 802.11ac -B WiFi</b>	1
CON-SNT-C1118PBW	SNTC-8X5XNBD ISR 1100 Dual GE Ethernet Router w/ 802	1
PWR-150W-AC	IP Base License for Cisco ISR 1100 8 Ports Series	1
SW1815I-ME-S-85	1100 Series AP1815i ME Single Software Image	1
SL-1100-8P-SEC	Security License for Cisco ISR 1100 8P Series	1
ISR-1100-POE4	ISR 1100 4 Ports 802.3at POE Module (4 POE or 2 POE+)	1
GREEN-OPTION	Eco-friendly - Ship router with only Power cables only	1
CAB-AC	AC Power Cord (North America), C13, NEMA 5-15P, 2.1m	1
ACS-1100-RM-19	Cisco 1100 Series Router Rackmount Wallmount Kit	1
SISR1100UK9-168	Cisco ISR 1100 Series IOS XE Universal	1

**Table E28: Small Access Switch**

Part Number	Description	Quantity
<b>C9300-24P-EDU</b>	<b>Catalyst 9300 24-port PoE+, K12</b>	1
C9300-NW-A-24	C9300 Network Advantage, 24-port license	1
S9300UK9-1612	Cisco Catalyst 9300 XE 16.12 UNIVERSAL	1
PWR-C1-715WAC-P	715W AC 80+ platinum Config 1 Power Supply	1

CAB-TA-NA	North America AC Type A Power Cable	1
C9300-SSD-NONE	No SSD Card Selected	1
C9300-STACK-NONE	No Stack Cable Selected	1
C9300-SPWR-NONE	No Stack Power Cable Selected	1
C9300-DNA-A-24	C9300 DNA Advantage, 24-port Term Licenses	1
PI-LFAS-T	Prime Infrastructure Lifecycle & Assurance Term - Smart Lic	1
PI-LFAS-AP-T-5Y	PI Dev Lic for Lifecycle & Assurance Term 5Y	1
NETWORK-PNP-LIC	Network Plug-n-Play Connect for zero-touch device deployment	1
C9300-DNA-A-24-5Y	C9300 DNA Advantage, 24-Port, 5 Year Term License	1

**Table E29: Access Point (for hallways and high density areas)**

Part Number	Description	Quantity
<b>MR46E-HW</b>	Meraki MR46E Wi-Fi 6 Indoor AP w External Antenna Connectors	1
MA-ANT-3-E6	Meraki Indoor Dual-band Wide Patch Ant, 6port MR46E/MR53E	1
MA-MNT-ANT-1	Meraki Standard Mounting Arm for E & F Series Patch Antenna	1
LIC-MR-ADV-5Y	Meraki MR Advanced License and Support, 5YR	1

**Table E30: Access Point (for classrooms)**

Part Number	Description	Quantity
<b>MR56-HW</b>	<b>Meraki MR56 Wi-Fi 6 Indoor AP</b>	1
LIC-MR-ADV-3Y	Meraki MR Advanced License and Support, 3YR	1

**Table E31: Access Point (for classrooms)**

Part Number	Description	Quantity
<b>MR57-HW</b>	<b>Meraki MR57 Wi-Fi 6E Indoor AP</b>	1
LIC-MR-ADV-3Y	Meraki MR Advanced License and Support, 3YR	1

**Table E32: Access Point (for outdoor w/ omni antennas)**

Part Number	Description	Quantity
<b>MR86-HW</b>	<b>Meraki MR86 Wi-Fi 6 Outdoor AP</b>	1
MA-ANT-20	Meraki Dual-band Omni Antennas	1
LIC-MR-ADV-5Y	Meraki MR Advanced License and Support, 5YR	1

**Table E33: Access Point (for outdoor)**

Part Number	Description	Quantity
MR86-HW	Meraki MR86 Wi-Fi 6 Outdoor AP	1
MA-ANT-25	Meraki Dual Band Patch Antenna	1
LIC-MR-ADV-5Y	Meraki MR Advanced License and Support, 5YR	1

**Miscellaneous Components (if needed)****Table E34: Switch X1 connectivity options (ordered with second 9500 X1 switch)**

Part Number	Description	Quantity
QSFP-100G-CU3M=	100GBASE-CR4 Passive Copper Cable, 3m	2
QSFP-100G-CU5M=	100GBASE-CR4 Passive Copper Cable, 5m	2

**Notes:**

\*Any equipment using the AP9571A model PDU for power will need to use the proper C13 to C14 power cable.

**IPDVS****Table E35: Lenovo SR650**

Part Number	Description	Qty	Notes/Comments
7X06U2WF00	LENOVO ThinkSystem SR650	1	
7X06 – CT01WW	Machine Type - Model	1	

**Table E36: Belkin Rack Console**

Part Number	Description	Qty	Notes/Comments
F1DC108H	19" LCD Console – 1U; Single Rail	1	
F1D9401-06	OmniView Dual Port Cable, USB	1	6' length

**Table E37: Server Cabinet**

Part Number	Description	Qty	Notes/Comments
AR3150	APC Netshelter 42U	1	

AP9563	APC 10 Outlet 19" Rack-mount 20Amp Power Strip	1	
AR8100	APC Netshelter Hardware Kit	1	

**Table E38: IDF Wall Mount Cabinet – 12RU Cabinet**

Part Number	Description	Qty	Notes/Comments
CWR-12-32PD	CWR Series Rack, CWR-12-32PD	1	
CWR-FKIT	Fan Kit, 190 CFM, CWR Series	1	
CWR-RR12	Rackrail, 12-24, 12 RU, CWR Series	1	

**Table E39: Lobby Viewing Console – Standard Console**

Part Number	Description	Qty	Notes/Comments
90338-SCA-48-S-7583M-H305-GR10	STRAIGHT MVS DESK WITH TWO DRAWER AND CPU COMPARTMENT	--	Optional by school
90338-SCA-48-W-7583M-H305-GR10	STRAIGHT MVS DESK ON COSTER WHEELS WITH TWO DRAWER AND CPU COMPARTMENT	--	Optional by school
90338-SCA-60-S-7583M-H305-GR10	STRAIGHT MVS DESK WITH THREE DRAWER AND CPU COMPARTMENT	--	Optional by school
90338-SCA-72-S-7583M-H305-GR10	STRAIGHT MVS DESK WITH FOUR DRAWER AND CPU COMPARTMENT	--	Optional by school
90339-SCA-48L-S-7583M-H305-GR10	LEFT ANGLED(FROM BEHIND THE DESK) MVS DESK WITH ONE DRAWER AND CPU COMPARTMENT	--	Optional by school
90339-SCA-48R-S-7583M-H305-GR10	RIGHT ANGLED(FROM BEHIND THE DESK) MVS DESK WITH ONE DRAWER AND CPU COMPARTMENT	--	Optional by school
90339-SCA-48L-W-7583M-H305-GR10	LEFT ANGLED(FROM BEHIND THE DESK) MVS DESK ON COSTER WHEELS WITH ONE DRAWER AND CPU COMPARTMENT	--	Optional by school
90339-SCA-48R-W-7583M-H305-GR10	RIGHT ANGLED(FROM BEHIND THE DESK) MVS DESK ON COSTER WHEELS WITH ONE DRAWER AND CPU COMPARTMENT	--	Optional by school
90490-SCA-72.72-L-7583M-H305-GR10	LEFT HAND (FROM BEHIND THE DESK)"L" SHAPED SECURITY MVS DESK WITH BOX/BOX/FILE DRAWER AND CPU COMPARTMENT	--	Optional by school

90490-SCA-72.72-R-7583M-H305-GR10	RIGHT HAND (FROM BEHIND THE DESK)"L" SHAPED SECURITY MVS DESK WITH BOX/BOX/FILE DRAWER AND CPU COMPARTMENT	--	Optional by school
90673-SCA-72.60-L-7583M-H305-GR10	LEFT HAND (FROM BEHIND THE DESK) ANGLED SECURITY MVS DESK WITH BOX/BOX/FILE DRAWER AND CPU COMPARTMENT	--	Optional by school
90673-SCA-72.60-R-7583M-H305-GR10	RIGHT HAND (FROM BEHIND THE DESK) ANGLED SECURITY MVS DESK WITH BOX/BOX/FILE DRAWER AND CPU COMPARTMENT	--	Optional by school

**Table E40: Lobby Viewing Console Alternative – Rolling Cart**

Part Number	Description	Qty	Notes/Comments
DS-3518-GMQ-T-2M-MK	48" wide by 30" deep adjustable height table with casters	1	2 casters capable of locking
CGLPVI-SEC-MT-MC-MK	Security device for a Tower CPU	1	
CGLP4-C/SD-MK	Security device for a monitor	2	for dual monitors

**Table E41: Uninterruptible Power Supply (UPS)**

Part Number	Description	Qty	Notes/Comments
SMX3KR2UNCX145	APC Smart-UPS X 3000VA Rack/Tower LCD 100-127V with Network Card & 10 FT Input Cord	1	

**Table E42: AXIS T8125 HIGH PoE+ 60 WATT MIDSPAN 1-PORT (POWER INJECTOR)**

Part Number	Description	Qty	Notes/Comments
5901-004	Axis High Power over Ethernet midspans	--	

**Table E43: AXIS P3375-LVE - FIXED POSITION – Indoor/Outdoor**

Part Number	Description	Qty	Notes/Comments
0476-001	Varifocal, 3–10 mm, F1.4, Horizontal field of view: 90°–34°, Vertical field of view: 50°–20°	--	General use

**Table E44: AXIS M3057-PLVE MK II – 6 MP - 180°/360° Indoor/Outdoor**

Part Number	Description	Qty	Notes/Comments
02109-001	1.56 mm, F2.0 Horizontal field of view: 183° Vertical field of view: 183° Fixed iris, fixed focus	--	Optional

**Table E45: AXIS P9106-V White – 3MP – Indoor corner camera**

Part Number	Description	Qty	Notes/Comments
01620-001	Varifocal 1.8 mm, F2.4, Horizontal field of view: 130° Vertical field of view: 95°	--	Optional

**Table E46: AXIS P3719-PLE – 16 MP – 4 Way (4 lenses) Indoor/Outdoor**

Part Number	Description	Qty	Notes/Comments
01500-001	Varifocal, 3–6 mm, F1.8–2.6 4 x 1440p capture mode: Horizontal field of view: 101°–49° Vertical field of view: 54°–29° Diagonal field of view: 116°–58° Motorized focus, motorized zoom	--	Optional

**Table E47: AXIS P5655-E – Indoor Small Form Factor PTZ**

Part Number	Description	Qty	Notes/Comments
01682-004	Varifocal, 4.3-137.6 mm, F1.4 - 4.0 Horizontal field of view: 58.3°- 2.4° Vertical field of view: 35.5°- 1.4° Including EIS, barrel and pincushion distortion correction Autofocus and auto-iris	--	Optional

**Table E48: AXIS Q6075-E – Outdoor PTZ**

Part Number	Description	Qty	Notes/Comments
01752-004	4.25–170 mm, F1.6–4.95 Horizontal field of view: 65.1°–2.00° (1080p) Vertical field of view: 39.1°–1.18° (1080p) Autofocus, auto-iris	--	General Use

**Table E49: AXIS Camera Mounting Accessories**

Part Number	Description	Qty	Notes/Comments
5502-321	AXIS P33-VE Pendant Mounting Kit (One per Exterior Fixed- wall, corner & parapet mount)	--	General Use
01156-001	AXIS T94M02L Recessed Ceiling Mount for P33	--	General Use
01461-001	AXIS T94T02D Pendant Kit (for Short Throw cameras)	--	General Use
01513-001	AXIS T94N01D Pendant Mounting Kit-Axis (One per 4 way)	--	General Use
01514-001	AXIS T94N01L Recessed Ceiling Mount (One per 4 Way)	--	General Use
5506-171	AXIS T94A02L Recessed Ceiling Mount One per indoor PTZ P5655-E	--	General Use
5502-431	AXIS T94A01D Pendant Kit (One per PTZ- wall, corner & parapet mount)	--	General Use
5503-721 (4 Pack) 5503-711(1-Pack)	NPS Conduit Adapter (One per Interior Fixed-wall & ceiling mount)	--	General Use
01165-001	AXIS T91B47 Pole Mount 50-150 mm	--	General Use
01164-001	AXIS T91B47 Pole Mount 100-410 mm	--	General Use
01818-001	AXIS TQ9601 Conduit Top Box (One for each corner cameras)	--	General Use
01190-001	AXIS T94S01P Conduit Back Box (for ST camera wall mount-surface conduit)	--	General Use
5507-461	AXIS T91B51 Ceiling Mount (5")	--	General Use
5507-491	AXIS T91B52 Extension Pipe (12") 30 CM	--	General Use
5507-481	AXIS T91B52 Extension Pipe (40") 100 CM	--	General Use
5504-641	AXIS T91B63 Telescopic Indoor Ceiling Mount (2 ft)	--	General Use
5507-451	AXIS T91B50 Telescopic Indoor Ceiling Mount (adjustable from 3.2 to 6 ft)	--	General Use
5507-641	AXIS T91H61 Wall Mount (14")	--	General Use
5506-481	AXIS T91E61 Wall Mount (5")	--	General Use
5504-821	AXIS T91D61 Wall Mount (9")	--	General Use
5017-641	AXIS T91A64 Corner Bracket	--	General Use
5507-271	AXIS T91D62 Telescopic Parapet Mount	--	General Use
Type C & LB	Eaton Conduit (Condulet bodies) and steel cover with Gasket for Commscope modular punch-down jack	--	General Use
UKJ600-ORG	Commscope Modular punch-down jack	--	General Use
5504-731	AXIS Outdoor Push-Pull RJ45 cable IP-66 rated 15M (only use with PTZ)	--	General Use
5502-731	AXIS Outdoor Push-Pull RJ45 cable IP-66 rated 5M (only use with PTZ)	--	General Use

**Analog Cameras**

**Table E50: PTZ CAMERA PARAPET MOUNTS**

Part Number	Description	Qty	Notes/Comments
PRM30G	VideoAlarm Parapet Mount - 23.3" Horizontal Span	--	As Needed
PRM50G	VideoAlarm Parapet Mount - 38.3" Horizontal Span	--	As Needed
VG4-A-9230	Bosch Parapet Mount - 40.2" Horizontal Span	--	As Needed

**Table E51: CAMERA BRACKETS AND MOUNTS**

Part Number	Description	Qty	Notes/Comments
PWM20G (Black)	Wall Mount for Exterior PTZ Camera in Black	--	As Needed
PACA2B (Black)	Corner Mount Bracket in Black	--	As Needed
PWM20GB (Beige)	Wall Mount for Exterior PTZ Camera in Beige	--	As Needed
PACA2 (Beige)	Corner Mount Bracket in Beige	--	As Needed

**Table E52: EXTERIOR CAMERA INTERFACE ENCLOSURE – GENERAL**

Part Number	Description	Qty	Notes/Comments
A606NF	J-Box, NEMA Type 4 Clamp Cover	--	As Needed

**Table E53: EXTERIOR CAMERA INTERFACE ENCLOSURE - WALL MOUNT CAMERA**

Part Number	Description	Qty	Notes/Comments
ATS-1084P-S-L-CG-BBP-CUST1	Acceltex NYDOE 10x8x4 Polycarbonate NEMA-4 Camera Interface Enclosure Wall Mounted Analog Cameras Enclosure with Solid Door, Latch Lock and Cord Grip (Outdoor Analog use only) ask vendor for installation instructions	--	As Needed

**Software**

**Table E54: Genetec Omnicast 4.x to 5.x / Security Center Upgrade**

Microsoft Licensing PCN # 8B277789: Select Plus Agreement # 6789556			
V. Part #	M. Part #	Description	Qty
228-11159	228-11159	SQLSvrStd 2017 ALNG MVL	1
359-06604	359-06604	SQLCAL 2017 ALNG MVL DvcCAL	6

**Table E55: Genetec Omnicast 4.x to 5.x / Security Center Upgrade**

Omnicast Licensing			
V. Part #	M. Part #	Description	Qty
GSC-UPGRADE	GSC-UPGRADE	Omnicast 4.x or Security Center 5.x to K12 EDU SKU 5.9 (for System ID)	1
GSC-BASE-5.9	GSC-BASE-5.9	Version Specification Part Number – No Cost	1
GSC-EDU-OM-BASE	GSC-EDU-OM-BASE	*** Not Required for Upgrades ***	0
GSC-EDU-OM-1C	GSC-EDU-OM-1C	Not required unless adding additional camera connection to existing system	
GSC-EDU-OM-COMMAND-1FED	GSC-EDU-OM-COMMAND-1FED	*** Not Required for Upgrades ***	0

**Table E56: Genetec Security Center New Site**

Microsoft Licensing PCN # 8B277789: Select Plus Agreement # 6789556			
V. Part #	M. Part #	Description	Qty
228-11159	228-11159	SQLSvrStd 2017 ALNG MVL	1
359-06604	359-06604	SQLCAL 2017 ALNG MVL DvcCAL	6

**Table E57: Genetec Security Center New Site**

Omnicast Licensing			
V. Part #	M. Part #	Description	Qty
GSC-UPGRADE	GSC-UPGRADE	*** Not Required for new sites ***	0
GSC-BASE-5.9	GSC-BASE-5.9	Version Specification Part Number – No Cost	1
GSC-EDU-OM-BASE	GSC-EDU-OM-BASE	Omnicast Education K12 base package – Version 5.9	1
GSC-EDU-OM-1C	GSC-EDU-OM-1C	1 camera connection (base package comes with 1 camera connection)	1
GSC-EDU-OM-COMMAND-1FED	GSC-EDU-OM-COMMAND-1FED	Fed Directory [Sys ID: GSC-140731-477989]	1

## Servers

**Table E58: Network Server**

Server 1		
Part	Description	Qty
7X02TVVU00-W/KVM	Lenovo ThinkSystem SR630	1
5WS7A01486	Extended service agreement - parts and labor - 3 years - on-site - business hours / 5 days a week - response time: NBD – for ThinkSystem SR630 7X02	1
F1DC108V	18.5inch Widescreen Rack Console	1
F1D9401-06	OmniView Dual-Port KVM Cable 6 ft USB	1
SVC-TS-SERVERCFG	SERVER CONFIG-HARDWARE ONLY, NO SOFTWARE	1

## Cabinets

**Table E59: Cabinets**

Part Number	Description	Qty
AR3150	NetShelter SX 42U 750mm Wide x 1070mm Deep Enclosure	1
NET9RMBLK-APC	Black Rackmount SurgeArrest 9 Outlet 120V	2
PSV-F16-15A-R	Vertical Rackmount Power Strip	2

**Table E60: Half Height Cabinets**

Part Number	Description	Qty
CWR-12-32PD	CWR Series Rack, CWR-12-32PD	1
CWR-FKIT	Fan Kit, 190 CFM, CWR Series	1
CWR-RR12	Rackrail, 12-24, 12 RU, CWR Series	1

**Table E61: Slim Cabinet**

Part Number	Description	Qty
AR106V	NetShelter WX Low-Profile Cabinet with 115V fan module and power cord IEC -C13 to NEMA 5-15P	1

**Power**

**Table E62: PDU**

Part Number	Description	Qty
AP9571A	Rack PDU, Basic, 1U, 30A, 208V, (10) C13	1

## Appendix F – Glossary of Terms

---

### Acronyms

The following are general abbreviations used in this document

APC	American Power Corporation
AWG	American Wire Gauge
BCDEDIT	Boot Configuration Data Editor (used to modify boot menu options – replaces boot.ini)
BOM	Bill Of Materials
BOMC	IBM Bootable Media Creator (used to create UpdateXpress packs for Firmware/BIOS flashing)
CAT	Cable and Telephone Wire Category
CCTV	Closed Circuit Television
CE	Custodian Engineer
CIP	Capital Improvement Program
DB-9	Serial Communications D-Shell Connector, 9 pins
DG	Drive Group (same as 'Array')
DIIT	Division of Instructional and Information Technology
DISKPART	Microsoft Disk Partition Shell Command Line Utility
DSF	Division of School Facilities
EMT	Electric Metallic Tubing
EULA	End User License Agreement
FMC	Flexible Metallic Conduit
FoD	Features on Demand
FTE	Field Test Equipment
GbE	Gigabit Ethernet
GRC	Galvanized Rigid Conduit
H.264	Video compression standard
HDD	Hard Disk Drive
HP	Hewlett Packard
HVAC	Heating Ventilation Air Conditioning
IBM	International Business Machines
IDF	Intermediate Distribution Frame
IMAGEX	Microsoft Image Restore Utility
IMM	Integrated Management Module (replaces RSA)
IP	Internet Protocol
IPDVS	Internet Protocol Digital Video Surveillance
KVM	Keyboard-Video-Mouse
LD	Logical Drive (same as 'Virtual Drive')

MDF	Main Distribution Frame
MSM	MegaRAID Storage Manager
MTM	Machine Type Model
MVS	Main Viewing Station
NEMA	National Electric Manufacturers Association
NIC	Network Interface Card
NMC	Network Management Card
NTP	Network Time Protocol
NYCDOE	New York City Department of Education
OOBE	Out of Box Experience (refers to first time server is booted after an image restoration)
OORS	Online Occurrence Reporting System
OSYD	Office of Safety and Youth Development
PCIE	Peripheral Component Interconnect Express
PDU	Power Distribution Unit
PID	Product ID
PTZ	Pan-Tilt-Zoom
RAM	Random Access Memory
RU	Rack Unit
RJ45	Registered Jack – 45 (8 wire used in networking)
SCA	New York City School Construction Authority
SFF	Small Form Factor
SI	System Integrator
SQL	Structured Query Language
SMTP	Simple Mail Transfer Protocol
SNMP	Simple Network Management Protocol
SSA	School Safety Agent
TC	Telecommunications Closet
TCP	Transport Control Protocol
UEFI	Unified Extensible Firmware Interface
UPS	Uninterruptible Power Supply
USB	Universal Serial Bus (connector)
UTP	Unshielded Twisted Pair
VD	Virtual Disk or Virtual Drive
VLAN	Virtual Local Area Network
VMK	Virtual Media Key
VRAM	Video Random Access Memory
VRF	Virtual Routing and Forwarding

The following are technical abbreviations used in this document

FR	Frame Relay
EVPL	Ethernet Virtual Private Line
FIOS	Verizon Fiber Optic Service
MODEM	Modulation Demodulation
DNS	Domain Name System
DHCP	Dynamic Host Communication Protocol
AD	Active Directory
VRF	Virtual Route Forwarding
BOM	Bill of Materials
LAN	Local Area Network
WAN	Wide Area Network
IP	Internet Protocol
MDF	Main Distribution Frame
IDF	Intermediate Distribution Frame
DFS	Department of Financial Services
VLAN	Virtual LAN
ATS	Automate the System
IPDVS	Internet Protocol Digital Video Surveillance
CAASS	Comprehensive Attendance Administration Security System
POE	Power over Ethernet
MTC	MetroTech Center
DIIT	Division of Instructional and Information Technology
POS	Point of Sale
VPN	Virtual Private Network
DMVPN	Dynamic Multipoint Virtual Private Network
CIPA	Children's Internet Protection Act
SCA	School Construction Authority
RMON	Remote Monitoring
SNMP	Simple Network Management Protocol
SSH	Secure Shell
ICMP	Internet Communication Management Protocol
CIR	Committed Info Rate
BTU	British Thermal Unit
UPS	Uninterruptible Power Supply